

# Maretron®

Vessel Monitoring & Control

We've got your **back[bone]**.



Maretron products include a full range of scalable network solutions for every size vessel. We are **your ONE source for creating the intelligent boat**—from cables and connectors to complete vessel monitoring and control solutions. [maretron.com](http://maretron.com)



**Maretron®**  
A Littelfuse® Brand



N2KView® Mobile is available as a free download





We are excited to announce the 2021 acquisition of Carling Technologies by Littelfuse, Inc., an industrial technology manufacturing company empowering a sustainable, connected, and safer world. Across more than 15 countries, and with 12,000 global associates, Littelfuse products are known for their reliability and performance in even the harshest environments.

Carling's leading position in switching and circuit protection technologies along with a strong global presence in the marine market provides exciting new opportunities for shared knowledge in applications and technologies.

The joining of our two companies will help drive deeper engagement with our customers and distribution partners and serve as a platform for future growth across the marine industry.

Together, we are committed to enabling rich product development and customer success, everywhere, every day.

**ALL MARETRON PRODUCTS ARE NMEA 2000® CERTIFIED\*** and have been tested and verified to meet specific critical safety criteria and to correctly implement network management and messaging. Certification involves a suite of more than 100 tests that a product must pass, including but not limited to: Priority Messaging (so the highest priority message always gets through; Auto Addressing (plug and unplug products without network interference); Product Information (understanding of products on the network); EMI and Noise Immunity Requirements; Electrical Isolation (assures that products do not disrupt the network).

- \* When manufacturers list products as NMEA 2000 'compatible' or 'compliant', the product has not been tested and probably does not meet the stringent SAFETY requirements designed into the NMEA 2000 specification. Without the testing and verification, there is no guarantee that the products will work in harmony and be safe.



Ask your NMEA dealer for Only NMEA 2000 Certified products and NMEA 2000 approved cables and connectors to ensure the highest level of reliability, interconnection, forward compatibility, and SAFETY!

NMEA 2000® Certified products are listed on the NMEA website [www.NMEA.org](http://www.NMEA.org).



# Product Catalog

<b>World-class Vessel Monitoring and Control</b>	<b>2</b>	<b>Electrical Monitoring and Control</b>	<b>58</b>
<b>User Interface Software</b>	<b>4</b>	ACM100 - Alternating Current Monitor .....	60
N2KView® Vessel Monitoring and Control Software .....	6	DCM100 - Direct Current Monitor .....	62
N2KView® Mobile .....	8	DCR100 - Direct Current Relay Module .....	64
Maretron Real Time Cloud Service .....	10	RIM100 - Run Indicator Module .....	66
N2KTracker® - Track Your Vessel on a Smartphone .....	12	<b>Digital Switching Platform</b> .....	<b>68</b>
Telemetric Cloud Service .....	14	CLMD12 - 12-Channel DC Load Controller Module .....	70
<b>User Interface Hardware Products</b>	<b>16</b>	CBMD12 - 12-Channel Bypass Module .....	72
WSV100 – MConnect HTML5 Web Server .....	18, 80	CLMD16 - 16-Channel DC Load Controller Module .....	74
TSM810C - 8" Vessel Monitoring and Control Touchscreen ....	20	VMM6 - Digital Switch Module .....	76
MBB300C - Maretron Black Box Vessel Monitoring & Control ...	22	CKM12 - Customizable Keypad .....	78
DSM410 - 4.1" High Resolution Color Display .....	24	WSV100 – MConnect HTML5 Web Server .....	80
DSM570 - 5.7" High Resolution Color Display .....	26	<b>General Systems Monitoring and Recording</b>	<b>82</b>
ALM100 - Alarm Module .....	28	SIM100 - Switch Indicator Module .....	84
<b>NMEA 2000® Gateways and Bridges</b>	<b>30</b>	FPM100 - Fluid Pressure Monitor .....	86
USB100 - NMEA 2000 to USB Gateway .....	32	RAA100 - Rudder Angle Adapter .....	88
IPG100 - NMEA 2000 to Internet Protocol Gateway .....	34	TMP100 - Temperature Module .....	90
J2K100 - J1939 to NMEA 2000 Gateway .....	36, 52	CLM100 - Current Loop Monitor .....	92
NBE100 - NMEA 2000 Bridge (Network Bus Extender) .....	38	VDR100 - Vessel Data Recorder .....	94
<b>Tank Monitoring</b>	<b>40</b>	<b>Navigation Instruments</b>	<b>96</b>
FPM100 - Fluid Pressure Monitor .....	42	WSO200 - Ultrasonic Wind and Weather Station .....	98
TLM100 - Tank Level Monitor .....	44	GPS200 - GPS Antenna/Receiver .....	100
TLM150 - Tank Level Monitor (Gasoline) .....	46	SSC300 - Solid State Compass .....	102
TLA100 - Tank Level Adapter .....	48	DST110 - Depth/Speed/Temperature Triducer .....	104
<b>Engine Monitoring</b>	<b>50</b>	<b>Cables and Connectors</b> .....	<b>106</b>
J2K100 - J1939 to NMEA 2000 Gateway .....	52	<b>NMEA 2000® Network Installation Guide</b>	<b>126</b>
FFM100 - Fuel/Fluid Flow Monitoring .....	54	N2KBuilder® .....	132
CLM100 - Current Loop Monitor .....	56	N2KAnalyzer® .....	133
		N2KExtractor® .....	134

# The World-class Standard in Vessel Monitoring and Control

---

**Designed to harness the power** of the NMEA 2000® marine networking protocol, Maretron® products seamlessly integrate a wide array of instrumentation, electronics and boat systems by providing one common and simple interface for all systems. Maretron products include a full range of scalable network solutions for every size vessel. Additionally, Maretron products are tested to the IEC 60945 standard for Maritime Navigational and Radiocommunication Equipment and Systems. We make boating easier, safer and more intuitive to the end user while making equipment installation more cost-effective and less time consuming.

As part of the Carling Technologies family, with over 100 years of expertise in switches and circuit protection, the Maretron brand includes global product support to OEMs, dealers, and boaters worldwide. We are your ONE source for creating the intelligent boat ... from cables and connectors to complete vessel monitoring and control solutions.

Marine has been our passion for decades. It's where we live, work and play—today, tomorrow and in the future.

***Your One Source for Creating  
the Intelligent Boat.***





1

**GPS / Weather**

GPS Antenna Receiver (GPS200)  
Wind & Weather Station (WSO200)



2

**Direct Current Relays**

Lighting, Pumps, etc. (DCR100)



3

**Switch Indicator Module**

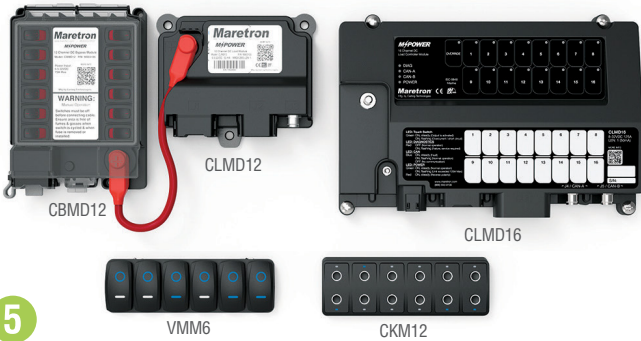
Smoke, CO, Gas, Doors, High Bilge (SIM100)



4

**Vessel Monitoring & Control/User Interface Products**

N2KView®, Color Displays (DSM410, DSM570, TSM810C), Black Box Monitor (MBB300C), Alarm Module (ALM100), Web Server (MConnect)



5

**MPower® Digital Switching Platform**

DC Load Controller Modules (CLMD12, CLMD16, Bypass Module (CMBD12)  
Contura® Rocker Digital Switch Module (VMM6), Customizable Keypad (CKM12)





6



### NMEA 2000® Gateway and Bridges

NMEA 2000 to USB (USB100)  
NMEA 2000 to Internet Protocol (IPG100)  
NMEA 2000 to Network Bus Extender (NBE100)

7



### Electrical Monitoring

Shore Power/Generator (ACM100)  
Battery/DC Source (DCM100)  
Run Indicator (RIM100)

8



### Solid State Compass

(SSC300)

9

10

11



### Tank Monitoring - Fuel, Water, Waste, Oil, Gasoline

Fluid Pressure Monitor (FPM100), Tank Level Monitors (TLM100, TLM150),  
Tank Level Adapter (TLA100)

12



### Depth/Speed/Temperature Triducer

(DST110)

13



### General Systems Monitoring/Recording

4-20mA Current Loop Monitor (CLM100)  
Temperature Monitor (TMP100)  
NMEA 2000® Vessel Data Recorder (VDR100)

14



### Engine Monitoring

Fuel/Fluid Monitor (FFM100)  
J1939 to NMEA 2000® Gateway (J2K100)

15



### Rudder Angle Adapter

(RAA100)







# User Interface Software Products

**Maretron user interface products** dramatically reduce the stress associated with keeping track of all your systems. In fact, every single parameter from every system onboard can be monitored 24/7 using programmable alerts or alarms, which gives you an early warning of potential problems before they become an annoyance or even a threatening situation. Furthermore, all vessel system information

is available through one highly intuitive and configurable user interface so you don't have to learn how to operate multiple disparate systems. And all the vessel monitoring and control information is networked, so you can get the data wherever it's needed, whether it be onboard or ashore, using desktop computers, laptops, handhelds, or tablets.



## N2KView®

*Vessel Monitoring and Control Software*



## N2KView® Mobile

*Vessel Monitoring and Control Software*



## N2KTracker® Mobile

*Smartphone/Tablet Vessel Tracking*



## Real Time Cloud Service

*Remote Vessel Monitoring and Control*

## Telemetric Cloud Service

*Vessel Tracking and Asset Management*







# N2KView®

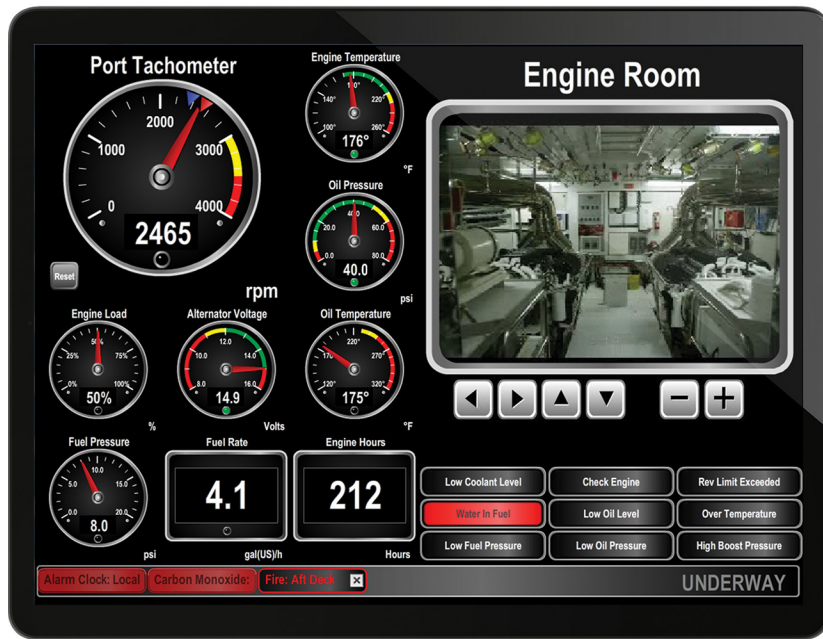
## Vessel Monitoring and Control Software

Whether you are interested in monitoring your vessel's systems while underway or remotely from your home or office, N2KView® software displays the information you need including engines, generators, tanks, rudders, navigation instruments, and more. N2KView® is completely user-configurable and you are free to create different screens for your exact needs while easily switching from screen to screen for monitoring all your systems. Digital displays, analog gauges, graphic displays, warning lights, and bar graphs, all can be configured exactly how you want them to be. You can even set the operating limits and color bands for analog gauges so you know when things are within limits and when they are not.

N2KView® is a comprehensive vessel monitoring and control software that goes beyond simple monitoring. With N2KView® you get additional functionality including alerts, video, switch control, anchoring supervision, and fuel management. The alerts functionality allows you to set up as many warnings and alarms as you need so you can be forewarned of potential problems. With alerts, you can relax knowing that the system is watching for smoke, carbon monoxide, high bilge water, or anything else you deem important. N2KView® video capability allows you to add cameras as part of the monitoring system—for example a camera in the engine room—or the cameras can be used as part of the

security system. The control functionality gives you the ability to manage your electrical system; for example, you can turn lights or pumps on or off directly from N2KView® and even tell if the lights or pumps are burned out and not working. Lastly, the fuel management function uses information from the fuel flow monitor, tank monitors, and GPS to provide advanced information like distance and time to empty as well as fuel rate and fuel economy.

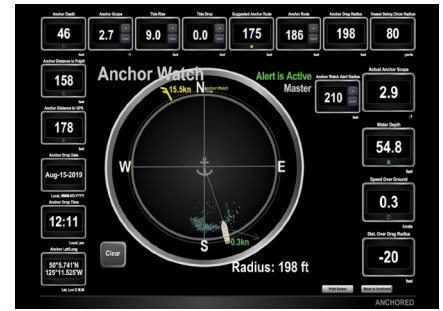
N2KView® software can run on your vessel's computer or on standalone products like the Maretron TSM810C display (page 20), or the Maretron Black Box (MBB300C) vessel monitoring system (page 22). If you want to run N2KView® software on your vessel's computer, you will need either a Maretron USB100 (page 32) or an IPG100 (page 34), to get sensor information from the NMEA 2000® network to the computer.



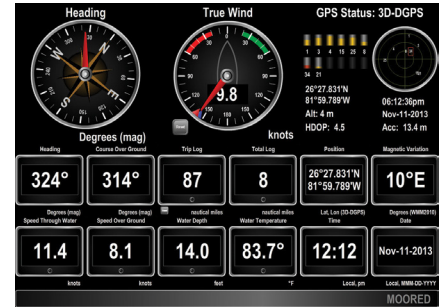
### PRODUCT

PART NUMBER	DESCRIPTION
N2KView®	N2KView® Vessel Monitoring and Control Software for Personal Computer
N2KView® Additional PC User Add-on	N2KView® Software License





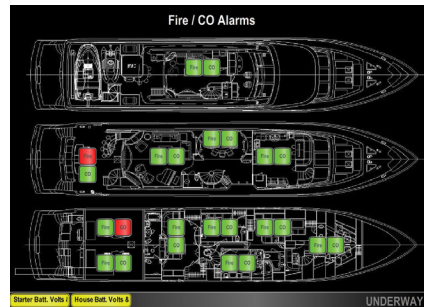
Anchor Watch



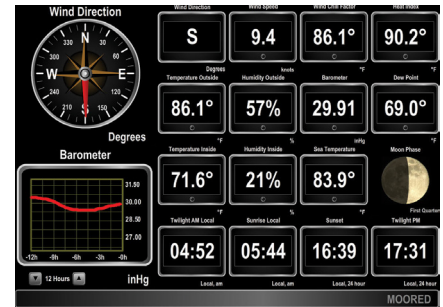
Navigation



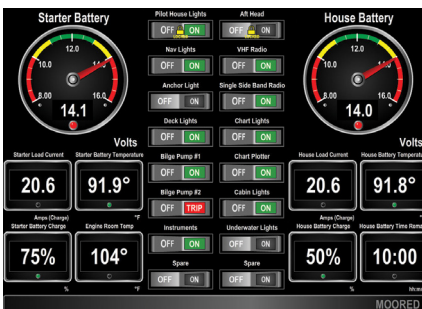
Engines



Fire Alarms



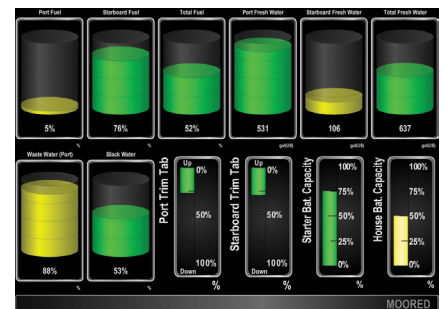
Environment



DC Systems



AC Systems



Tank Levels

## WINDOWS PC SERVER/CLIENT SYSTEM REQUIREMENTS

PARAMETER	VALUE	COMMENT
Operating System	7/8/10/11	Latest service packs may be required for support
CPU Minimum	Intel Atom	
CPU Recommended	Intel Core i3	
Memory Minimum	512MB RAM	
Memory Recommended	1GB RAM	
Hard Drive Space	100 MB	
Video Card Minimum	128 MB	
Video Card Recommended	256 MB	
USB Ports	2.0 or 3.0 Compatible	Required to connect through USB100, or to load software from shipped media
Network Connections	10/100/1000Base-T or 802.11 b/g/n/ac/ax	Only required if connecting through IPG 100 or viewing network based cameras
Display Minimum	800 x 480 Resolution 32-bit Color Video	

# N2KView® Mobile

N2KView® Mobile software allows you to monitor and control your vessel's systems from your smartphone or tablet device. This includes Android™ (2.2 and higher) Apple iPod, iPhone, and iPad. Whether it's onboard via Wi-Fi or ashore via an Internet connection, you can see what is happening aboard your vessel and even control things like your air conditioner, watermaker, lights, pumps, and more.

What makes N2KView® Mobile so diverse is its ability to configure screens (layout of each screen, and the size and type of each parameter you wish to display). Customize each display exactly the way you want it. Use N2KView® on a computer to design the screens, and then upload them to the IPG100 and download them to your smartphone or tablet.

N2KView® Mobile can be downloaded free of charge directly from Google Play to your Android device or directly to an Apple device from the iTunes store. You will need a Maretron Internet Protocol Gateway (IPG100, page 34) to get the sensor data onto the vessel's Wi-Fi for onboard viewing or onto the Internet for remote viewing.



## PRODUCT

PART NUMBER	DESCRIPTION
N2KView® Mobile Android	Free download from Google Play Store
N2KView® Mobile Apple	Free download from iTunes



### N2KVIEW® MOBILE FOR Apple iPod, iPhone, iPad

PARAMETER	VALUE
Hardware	iPhone 8 or later
	iPad, iPad 2, or later
Operating System	iOS 9.0 and above
Image Size	42.7 MB
Screen Orientation	Portrait or Landscape
Connection to N2KServer	Encrypted using SSL encryption

### N2KVIEW® MOBILE FOR ANDROID

PARAMETER	VALUE
Hardware	Any hardware running Android OS
Operating System	Android Version 4 and above
Image Size	Varies with device (about 40MB)
Screen Orientation	Portrait or Landscape
Connection to N2KServer	Encrypted using SSL encryption



# Maretron Real Time Cloud Service

Maretron Real Time Cloud Service allows you to remotely and seamlessly connect to your vessel using N2KView® or N2KView® Mobile software in order to monitor and control your vessel from anywhere in the world. As long as there is an Internet connection to the vessel, the Maretron Internet Protocol Gateway (IPG100) will automatically log into the Maretron Real Time Cloud Server and the vessel's information will be made available to any device running N2KView® or N2KView® Mobile. Connection between your vessel and remote N2KView® software has never been easier, whether your vessel's Internet connection is via a marina Wi-Fi, satellite connection, GSM or cell phone modem, or any other type of Internet connection, you'll have access to the vessel from anywhere in the world.

Using Maretron Real Time Cloud Service is simple, just imagine receiving an email or text notification from the vessel indicating a problem and you simply log onto the vessel using a smartphone, tablet, or PC. Using the Maretron N2KView® vessel monitoring and control software you'll have a better

understanding of the problem and can even initiate a corrective action like resetting tripped breakers, turning on auxiliary pumps or lights, etc. Or maybe you want to adjust the air conditioner or start the ice maker on your way to the boat. Maretron Real Time Cloud Service provides you with a seamless connection to your vessel for peace of mind and convenient access from anywhere in the world.

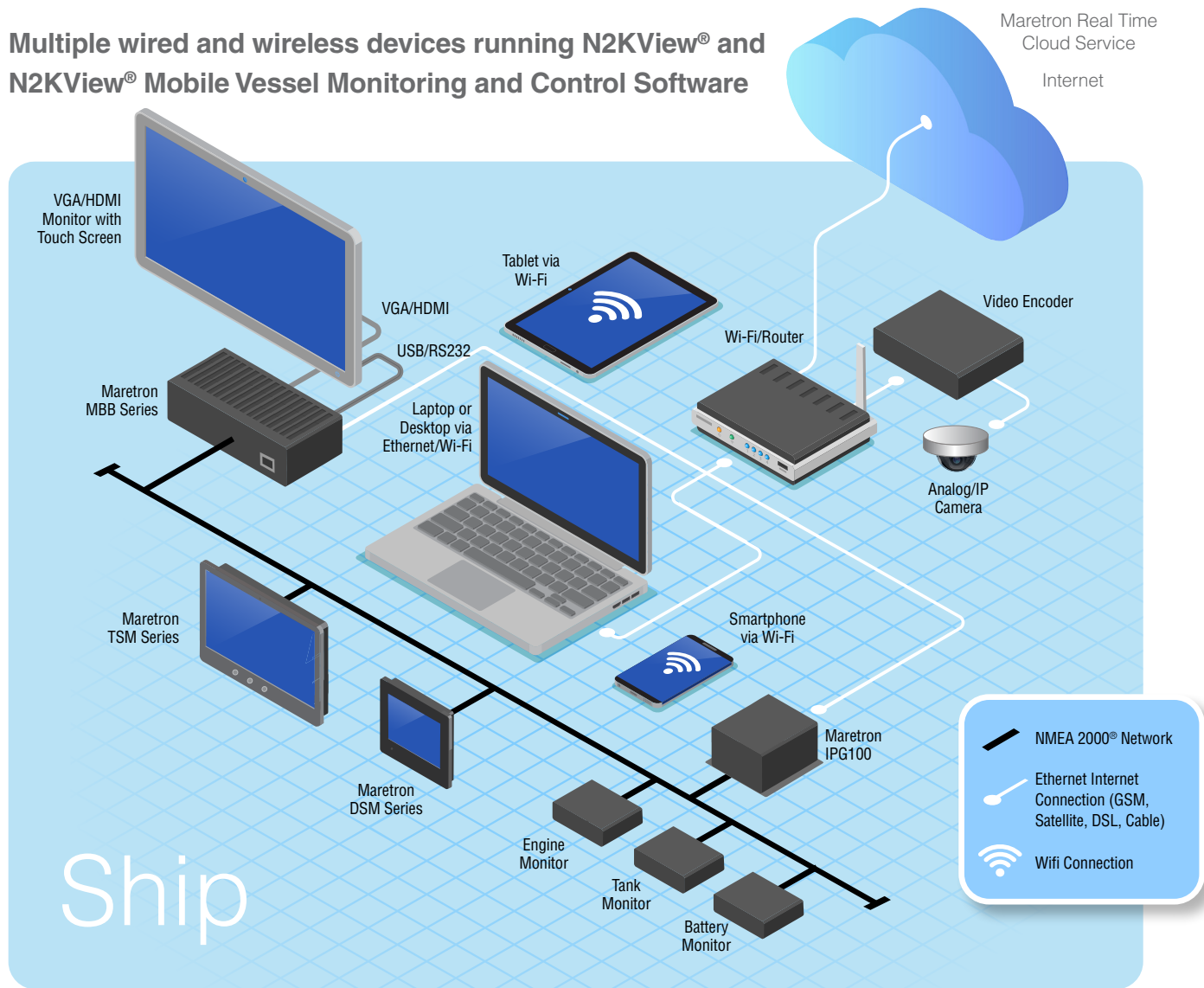


## PRODUCTS

PART NUMBER	DESCRIPTION
MCS-25GB	Remote Vessel Monitoring & Control Data Plan (1 Year Contract Required-25GB/month)
MCS-50GB	Remote Vessel Monitoring & Control Data Plan (1 Year Contract Required-50GB/month)
MCS-100GB	Remote Vessel Monitoring & Control Data Plan (1 Year Contract Required-100GB/month)



## Multiple wired and wireless devices running N2KView® and N2KView® Mobile Vessel Monitoring and Control Software



## Remote wired and wireless devices running N2KView® and N2KView® Mobile



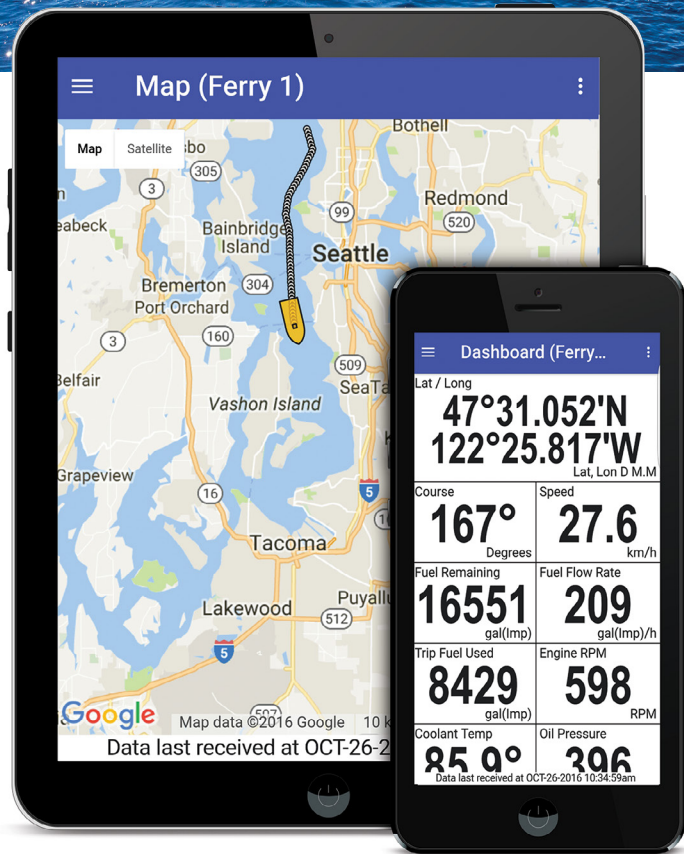
# N2KTracker®

## Track Your Vessel on a Smartphone

N2KTracker® is a free App that shows your boat's position and recent track on a Google map. It also allows you to create, enable, and disable a geofence around your boat's position so that you or others can be alerted if your boat leaves a specified area, and allows you to enable and disable notifications via e-mail or SMS text message.

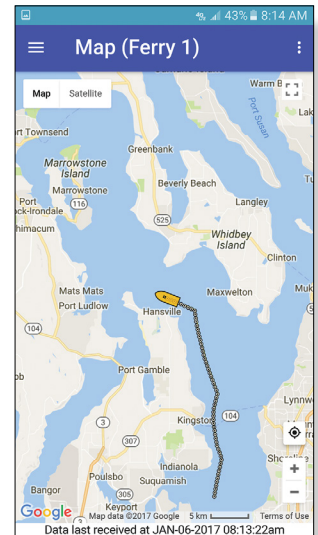
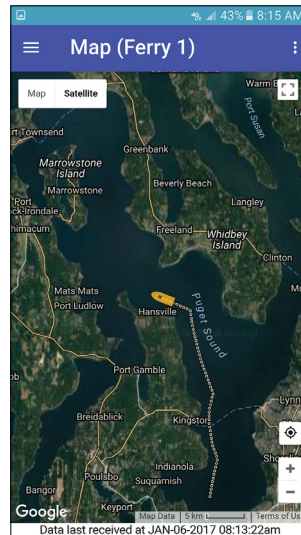
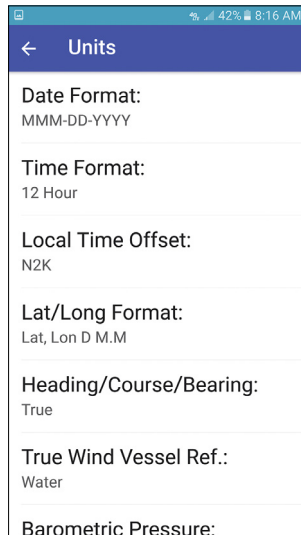
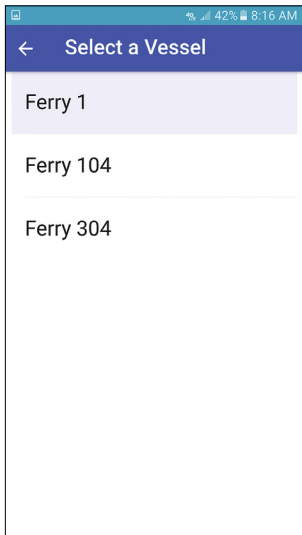
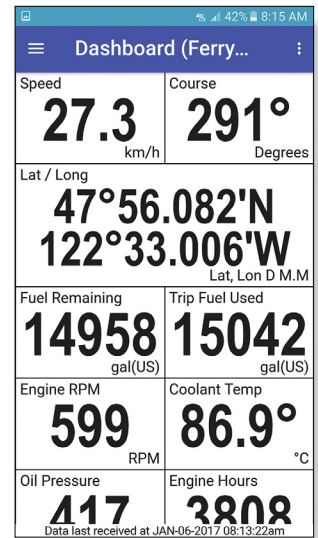
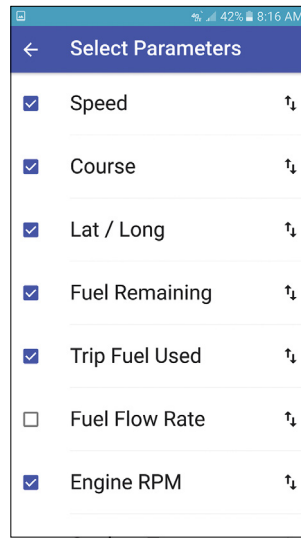
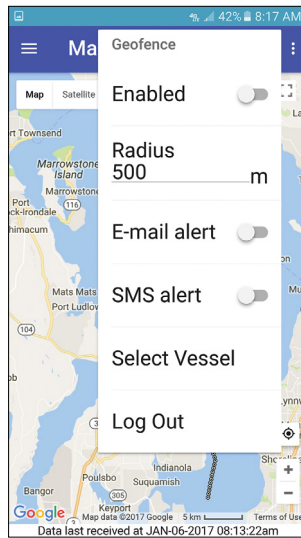
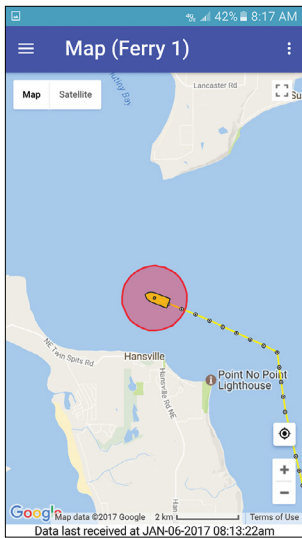
N2KTracker® also has a dashboard function so that you can select any data stored on the cloud for viewing, such as engine hours for maintenance tracking, fuel levels for cost management, engine parameters so that you can ensure proper operational procedures are being followed, or bilge pump runtime to ensure your boat will remain safely afloat.

N2KTracker® works equally well whether you have a single boat and want to share your voyage with friends, or if you manage a fleet, allowing you to quickly and easily change the selection of the vessel you are viewing.



### PRODUCTS

PART NUMBER	DESCRIPTION
N2KTracker® Android	Free download from Google Play Store
N2KTracker® Apple	Free download from iTunes



## N2KTRACKER® FOR APPLE IOS

PARAMETER	VALUE
Hardware	iPhone / iPad
Operating System	iOS 8 or higher
File Size	21.8 MB
Screen Orientation	Portrait and Landscape
Connection to Maretron Telemetric Cloud Service	SSL Encrypted

## N2KTRACKER® FOR ANDROID

PARAMETER	VALUE
Hardware	Any hardware running Android OS
Operating System	Android version 4 (Ice Cream Sandwich) or higher
File Size	3.4 MB
Screen Orientation	Portrait and Landscape
Connection to Maretron Telemetric Cloud Service	SSL Encrypted



# Telemetric Cloud Service

Maretron Telemetric Cloud Service uses the vessel's existing Internet connection (cellular, Wi-Fi, satellite, etc.) to broadcast selected information about the vessel to the Maretron Cloud Server where the data is stored and subsequently accessed from the shore via a computer, smartphone, or tablet device. Using Maretron Telemetric Cloud Service allows you to protect your investment through near real-time tracking of your vessel and it allows you to manage the operation of your assets such as scheduling preventive maintenance or optimizing performance such as fuel usage.

The type of data transmitted off the vessel is limited only by the Maretron NMEA 2000® sensors making up the onboard vessel monitoring system. This might be as simple as a single GPS antenna/receiver used for tracking the vessel, or it may include many sensors for monitoring engines, generators, fuel rate, tank levels, batteries, and more. Selecting which data is monitored and how often it is transmitted to the cloud from the vessel is a simple matter using a Maretron touchscreen (TSM810C) or Black Box (MBB300C). This gives you the flexibility to decide which information is important and how often it is transmitted while balancing it against your airtime cost. The system has been designed to be extremely efficient for minimizing airtime, plus the system is designed to be very robust for situations where Internet connectivity is intermittent or moving through areas of spotty coverage.

With regard to accessing cloud data from ashore, there are two methods. First, there is a free smart-phone/tablet application called N2KTracker®, which is a Google map showing your boat's current position and its track over the last hour. You can set a geo-fence so if the boat moves outside your programmed circle radius, you'll get a text message or email notifying you that the vessel is on the move. N2KTracker® also has a dashboard function where you can select any data stored in the cloud for display. For a more detailed analysis of the data stored in the cloud, Maretron offers a free PC-based software program called N2KExtractor®. N2KExtractor® shows the boat and track on a map for the selected time period, plus it allows you to graph up to four parameters while correlating the data with the vessel's position. Alternatively, N2KExtractor® allows any number of user selected parameters for a user selected time period to be extracted in the form of a spreadsheet file for detailed performance analysis or preventive maintenance.



*N2KTracker®  
Android/Apple App*



*N2KExtractor® PC Software*



## Commercial Application



Vessel's existing internet connection



Telemetric Cloud Service  
Vessel Tracking & Asset Management



**N2KExtractor®**  
PC Software for Data Analysis

## Recreational Application



Vessel's existing Internet connection



Telemetric Cloud Service  
Vessel Tracking & Asset Management



**N2KTracker®**  
Android/Apple App

# User Interface Hardware Products

**If you think about all the systems** onboard a vessel and what needs to be monitored to keep each person safe, secure, and comfortable, it can be a daunting task. Is there enough fuel to make it to the destination, is the engine overheating, is the bilge filling up with water, is there carbon monoxide in the sleeping quarters? Maretron user interface products dramatically reduce the stress associated with keeping track of all your systems. In fact, every single parameter from every system onboard can be monitored 24/7 using programmable alerts

or alarms, providing you with an early warning of potential problems before they become an annoyance or even a threatening situation. Furthermore, all vessel system information is available through one highly intuitive and configurable user interface so you don't have to learn how to operate multiple disparate systems. All the vessel monitoring and control information is networked, so you can get the data wherever it's needed, whether it be onboard or ashore, using desktop computers, laptops, tablets or smartphones.





**NEW!**



**WSV100**  
*MConnect HTML5 Web Server*



**ALM100**  
*Alarm Module*



**TSM810C**  
*8" Vessel Monitoring and Control Touchscreen*



**MBB300C**  
*Black Box Vessel Monitoring and Control*



**DSM410**  
*4.1" High Resolution Color Display*



**DSM570**  
*5.7" High Resolution Color Display*

# MConnect

## HTML5 Web Server

Designed for vessels of all sizes, the new MConnect® Web Server provides real time data on web pages that can be displayed on multiple phones, tablets, PCs or MACs—simultaneously. Following the design paradigm of Maretron's award-winning N2KView® Vessel Monitoring and Control Software, MConnect's engaging and informative graphic controls make it easy to display a large amount of critical data.

Pages can also be displayed on marine Multifunction Displays (MFDs) that support remote HTML servers such as Garmin OneHelm™ and Raymarine LightHouse 4 as well as full integration with digital switching systems such as Octoplex® and MPower®.

Through innovative use of color and high-definition graphics, the health of your boat is displayed at a glance as this information is seamlessly rolled up to other screens, bringing attention to potential problems. MConnect is fast, seamless, and easy to learn with an uncluttered interface that is customizable.

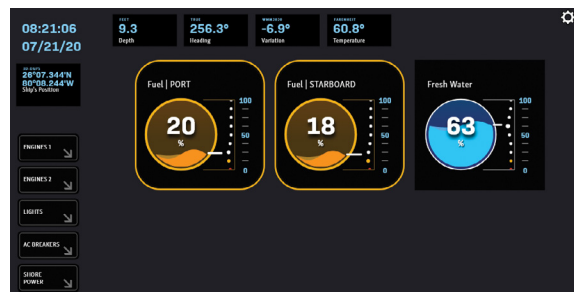
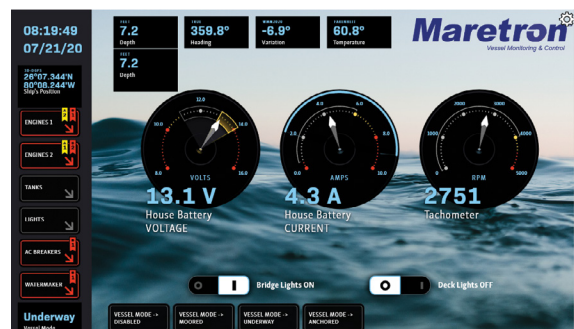
MConnect has direct connections to two NMEA 2000 busses, and receives data from both, independently. This means that MConnect can monitor Primary and Secondary busses, or independent Navigation and Monitoring busses without the need for a bridge.

With multiple simultaneous users, and a low price point, MConnect makes comprehensive vessel monitoring available to more users than ever before.

# MConnect

## Product features:

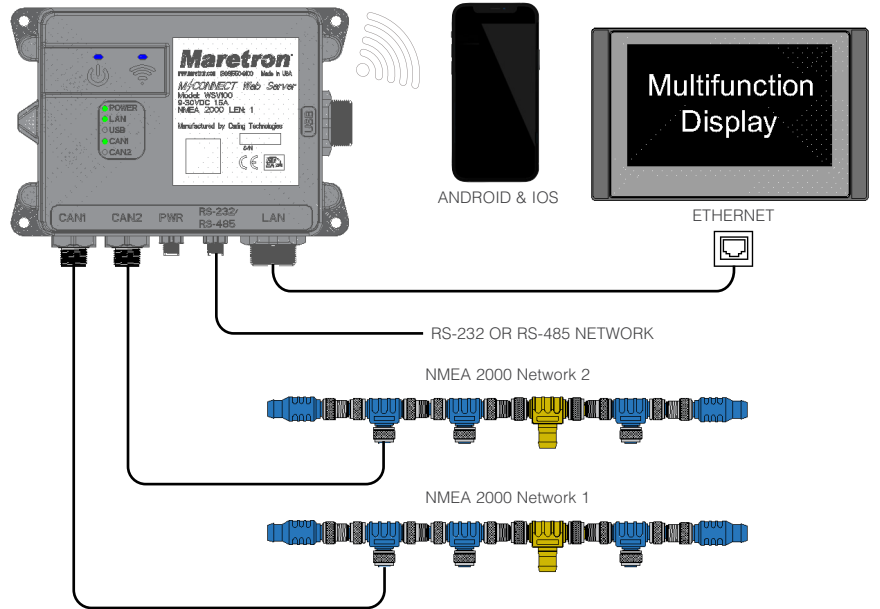
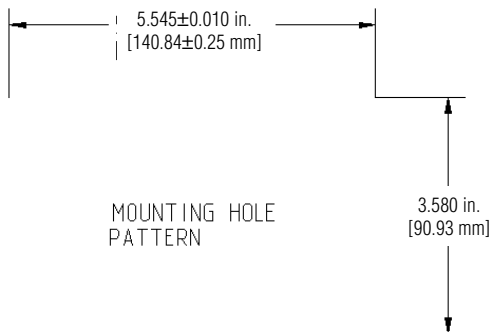
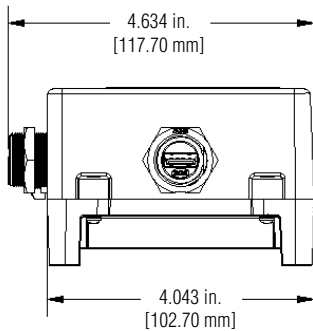
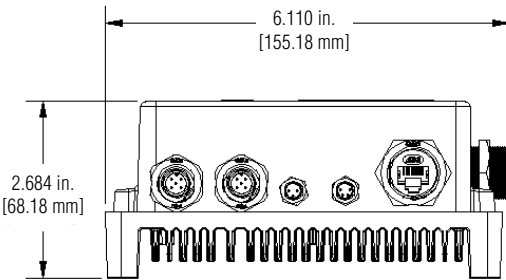
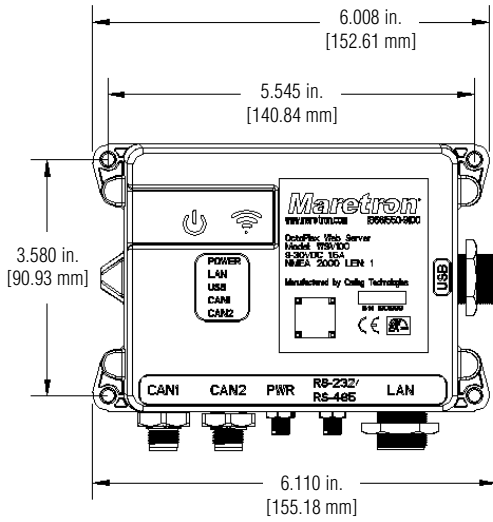
- IP67 Rated
- Dual CAN Bus for single or redundant NMEA 2000® Network Connections
- USB 3.0 Port
- RJ45 Ethernet Port
- Can support simultaneous access from up to (4) users
- 9-32 Volt Power Input (Reverse Polarity Protected)
- 5 Watt Power Usage
- Engaging HTML5 User Interface Experience



## PRODUCTS

PART NUMBER	DESCRIPTION
WSV100	MConnect HTML5 Web Server

# MConnect



## SPECIFICATIONS

PARAMETER	VALUE	COMMENT
(2) CAN Ports	NMEA 2000 Micro-C	For Connectivity to NMEA 2000
Serial Port	UART Interface	Switchable between RS-485 and RS-232 Protocols
USB Port	USB 3.0	For Software Updates and File Uploading
RJ45 Ethernet	1Gb/s	HTTP/HTTPS Port
Web Browser®	HTML5/JavaScript	To Support MFD Connectivity

## ELECTRICAL

PARAMETER	VALUE	COMMENT
Operating Voltage	9–32 Volts	DC Voltage (Dedicated Power Connection)
Power Consumption	5 Watts	Typical
Operating Voltage (NMEA 2000 Connection)	8–32 Volts	DC Voltage
Power Consumption (NMEA 2000 Connection)	50mA	1 LEN
Reverse Polarity Protection	Yes	NMEA 2000 & Power Connection

## MECHANICAL

PARAMETER	VALUE	COMMENT
Overall Dimensions (D x W x H)	2.68" x 6.00" x 4.04" (68.18 mm x 152.61 mm x 102.70mm)	Excluding Connectors
Weight	3 lbs. (1.36 kg)	
Mounting	Screw Mount	4 x #10 Screw Recommended, (Horizontal or Vertical Mounting Orientation)
Material	ABS Plastic Front Aluminum Back	
Heat Dissipation	Aluminum Heatsink	Air Cooled

## ENVIRONMENTAL

PARAMETER	VALUE
Operating Temperature	-20°C to 70°C
Storage Temperature	-40°C to 85°C
Ingress Protection	IP67

## CERTIFICATION

AGENCY
FCC Part 15
CE
NMEA 2000



# TSM810C

## 8" Vessel Monitoring and Control Touchscreen

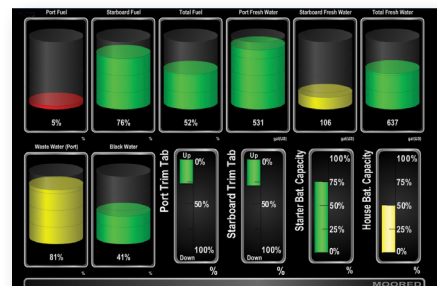
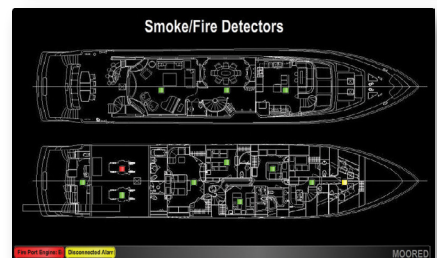
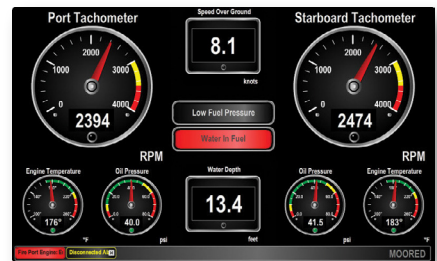
The TSM810C is an 8" dedicated touchscreen that includes the Maretron N2KView® vessel monitoring and control software. The N2KView® software allows you to configure as many favorite screens as you want with exactly the information you want to see. The TSM810C provides an extremely simple touch interface for monitoring and controlling critical systems from anywhere on the vessel.

The TSM810C is ruggedized for marine use and includes a solid state disk drive to withstand the pounding associated with waves. And since the TSM810C only dissipates 10 watts, there is no need for internal cooling fans that are noisy and wear out, causing electronics to overheat and fail. The TSM810C can be mounted outside given the high bright screen and waterproof front.

As an alternative to controlling the TSM810C through the touchscreen, the TSM810C includes two USB ports for connecting keyboards, mice, or trackballs. The TSM810C also has an Ethernet port for connecting Internet Protocol (IP) cameras for viewing within the N2KView® software. Lastly, the TSM810C contains two completely isolated CAN bus connectors (M12) for easy connection to single or redundant NMEA 2000® networks.

### Product features:

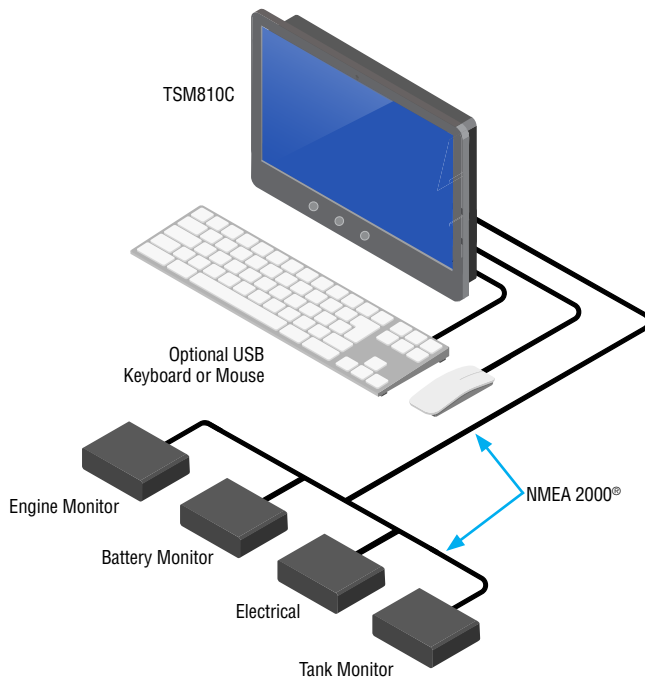
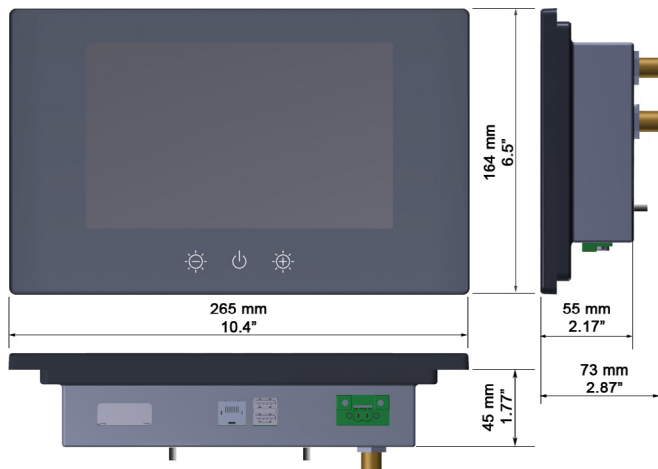
- 8" TFT LCD panel, LED backlit
- Widescreen aspect ratio 5:3
- 800 x 480 pixels
- 1350 nits brightness (optically bonded)
- Solid state disk drive
- Fanless cooling system
- Flush or VESA mounting
- Dual CAN Bus for single or redundant NMEA 2000® Network Connections
- Dust cover included



TSM810C Screen Shots

### PRODUCT

PART NUMBER	DESCRIPTION
TSM810C-01	8" Vessel Monitoring and Control Touchscreen (Direct NMEA 2000® Connection)
TSM810C-01-Dust-Cover	



## SPECIFICATIONS

PARAMETER	VALUE	COMMENT
Display Size	8"	LED Backlit LCD with Projected Capacitive Touchscreen
Display Resolution	800x480	WVGA
Display Brightness	1350cd/m2	Optically bonded
Contrast Ratio	600:1	
LCD Color	262K	
Viewing Angle	80° H, 80° V	
USB Ports	1x USB 2.0, 1x USB 3.0	
Ethernet Ports	One RJ-45 GbE	For connection to IP Cameras, Email Notification Alerts*, Maretron Telemetric Cloud Services* and Remote Updates*
Controller Area Network (CAN) Ports	Two Waterproof (M12)	Dual NMEA 2000® connection

## ELECTRICAL

PARAMETER	VALUE	COMMENT
Operating Voltage (Dedicated Supply Connection)	10–32 Volts	DC Voltage
Power Consumption (Dedicated Supply Connection)	10 Watts	Typical
	15 Watts	Maximum
Operating Voltage (NMEA 2000® Connection)	8–32 Volts	DC Voltage
Power Consumption (NMEA 2000® Connection)	50mA	
Load Equivalence Number (LEN)	1	NMEA 2000® Spec. (1 LEN = 50mA)
Reverse Battery Protection (NMEA 2000® Connection)	Yes	Indefinitely
Load Dump Protection (NMEA 2000® Connection)	Yes	Energy Rated per SAE J1113

## MECHANICAL

PARAMETER	VALUE	COMMENT
Overall Dimensions (DxWxH)	2.01" x 10.44" x 6.54" (51mm x 265mm x 166mm)	Depth includes NMEA 2000® Connectors
Weight	4.2 lbs (1.9kg)	
Front Panel Material	Glass	
Front Panel Controls	Power, Brightness +/-	
Mounting	4 x M4 VESA Mounting 75mm x 75mm	Screws protrude from back
	Front Mount flush into console with 6 screws	6 x M5 x 15mm screws

## ENVIRONMENTAL

PARAMETER	VALUE
Operating Temperature	-20°C to 55°C (Humidity up to 95%)
Storage Temperature	-30°C to 60°C (Humidity up to 95%)
IP Rating	IP66 Front, IP22 Rear (EN60529)

## APPROVALS

PARAMETER
IEC 60945
NMEA 2000®

\* Requires an active Internet connection

# MBB300C

## Black Box Vessel Monitoring and Control

The third generation Black Box (MBB300C) is a dedicated processing unit that includes N2KView® vessel monitoring and control software. Unlike a PC that allows any software to be loaded, the MBB300C runs only N2KView® software making it extremely stable and dedicated to monitoring and controlling your vessel. The MBB300 is compatible with Garmin OneHelm™ and Raymarine LightHouse 4.

The MBB300C is ruggedized for marine use and includes a solid state disk drive to withstand the pounding associated with waves. And since the MBB300C dissipates less than 10 watts, there is no need for internal cooling fans that are noisy and wear out causing electronics to overheat and fail.

The MBB300C connects to a monitor through a VGA connector or an HDMI connector while the associated touchscreen connects through a USB or serial port. Alternatives to controlling the N2KView® software through a touchscreen include keyboards, mice, or track balls connected through USB. In addition to the two completely isolated CAN bus connectors for simple connection to single or redundant NMEA 2000® networks, the MBB300C has an Ethernet port for connecting Internet Protocol (IP) cameras for viewing within the N2KView® software.

Of course you get the same flexibility using Maretron's N2KView® software from the MBB300C as you would running the software on a PC, which includes the ability to configure as many screens as you want with exactly the information you want to see. Plus you get free upgrades to the software as improvements and new features are added.

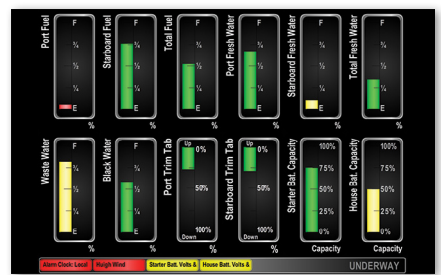
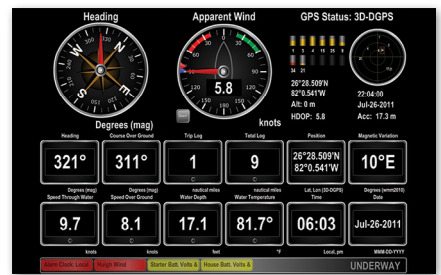
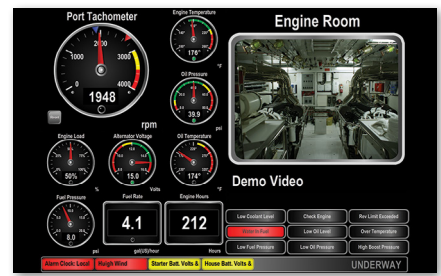
**Compatible with  
Garmin OneHelm™  
and Raymarine  
LightHouse 4**



\* Requires an active internet connection.

### Product features:

- 9–36 Volt Power Supply
- Solid State Disk Drive
- Fanless Cooling System
- Dual CAN Bus for single or redundant NMEA 2000® Network Connections
- Four USB Ports for touchscreen, keyboard, mouse, trackball, or thumb drive connections
- VGA or HDMI video connection (2560 x 1600 maximum resolution)
- Ethernet connector for IP Camera Input, Email Alert Notification\*, and Maretron Telemetric Cloud Service\*

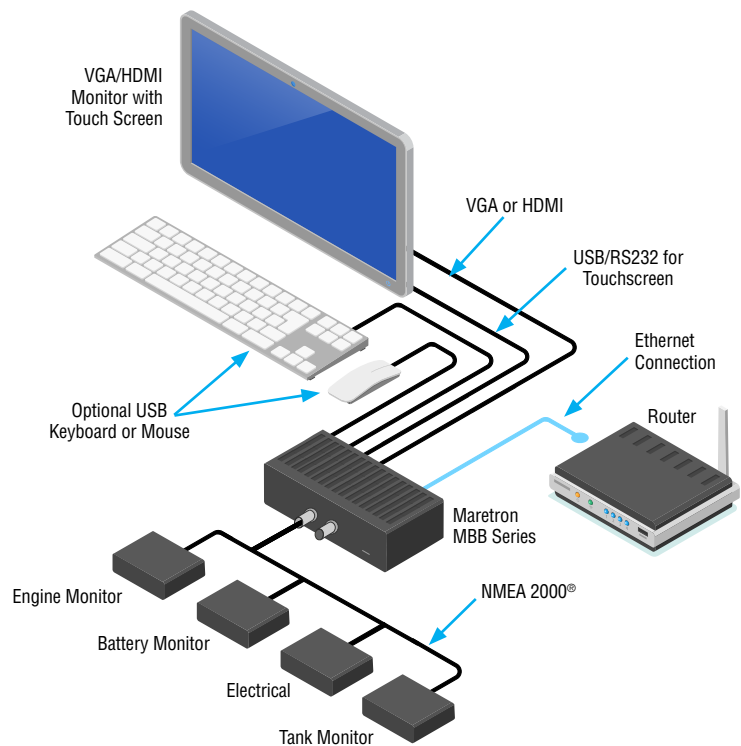
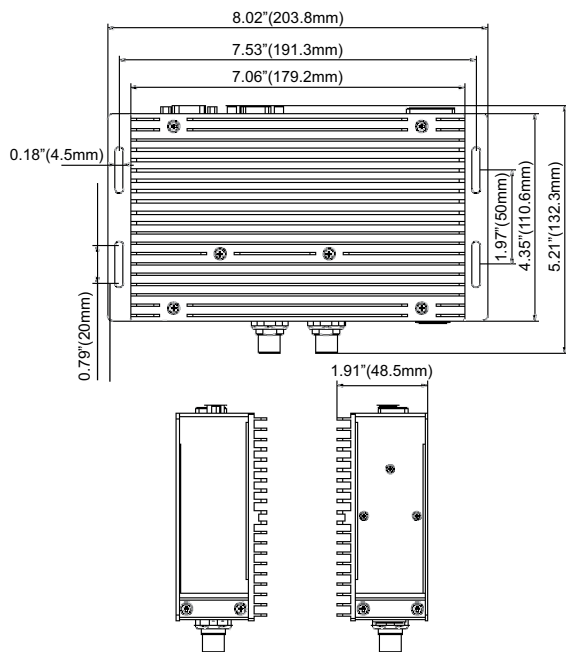


MBB300C Screen Shots

### PRODUCT

PART NUMBER	DESCRIPTION
MBB300C-01	Black Box Vessel Monitoring and Control





## SPECIFICATIONS

PARAMETER	VALUE	COMMENT
Video Connector	VGA Port HDMI Port	For monitor connection
Monitor Resolution	2560 x 1600 Maximum (VGA) 1920 x 1080 Maximum (HDML)	
USB Connector	Two USB 3.0 connections Two USB 2.0 connections	For connecting peripherals (mouse, keyboard, etc.) and/or touchscreen connectivity
Serial Connector	One RS232 9-Pin D Connector	For touchscreen alternative connection
Touchscreen Drivers	TSHARC, 3M MicroTouch, ELO, eGafax, General Touch	Compatible with HID touch compliant panels
Ethernet Ports	RJ-45 GbE	For connection to IP Cameras, Email Notification Alerts*, Maretron Telemetric Cloud Services*, Remote Updates*, and HTML5 Remote
Controller Area Network (CAN) Ports	Two NMEA 2000® Micro-C Connectors	

## ELECTRICAL

PARAMETER	VALUE	COMMENT
Operating Voltage (Dedicated Supply Connection)	9–36 Volts	DC Voltage
Power Consumption (Dedicated Supply Connection)	10 Watts	Maximum
Operating Voltage (NMEA 2000® Connection)	8–32 Volts	DC Voltage
Power Consumption (NMEA 2000® Connection)	80mA	Maximum when Transmitting 100%
Load Equivalence Number (LEN)	1	NMEA 2000® Spec. (1 LEN = 50mA)
Reverse Battery Protection (NMEA 2000® Connection)	Yes	Indefinitely
Load Dump Protection (NMEA 2000® Connection)	Yes	Energy Rated per SAE J1113

## MECHANICAL

PARAMETER	VALUE	COMMENT
Overall Dimensions (DxWxH)	5.21" x 8.02" x 1.91" (132.3mm x 203.8mm x 48.5mm)	Excluding connectors and wall brackets
Weight	2.27 lbs (1.03 kg)	
Front Panel Material	Aluminum	
Mounting	4 x M4 VESA Mounting 75mm x 75mm	Any orientation

## ENVIRONMENTAL

PARAMETER	VALUE
Operating Temperature	-20°C to 70°C
Storage Temperature	-40°C to 85°C
Humidity	10%–85% RH non-condensing

## CERTIFICATIONS

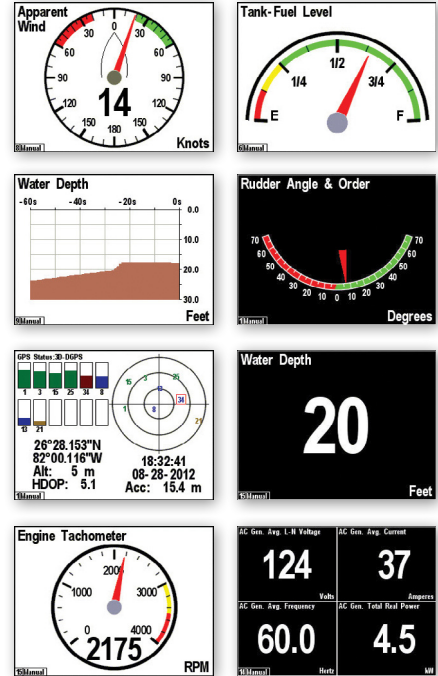
PARAMETER	COMMENT
FCC Class A and CE Mark	Electromagnetic Compatibility
NMEA 2000®	

\* Requires an active internet connection

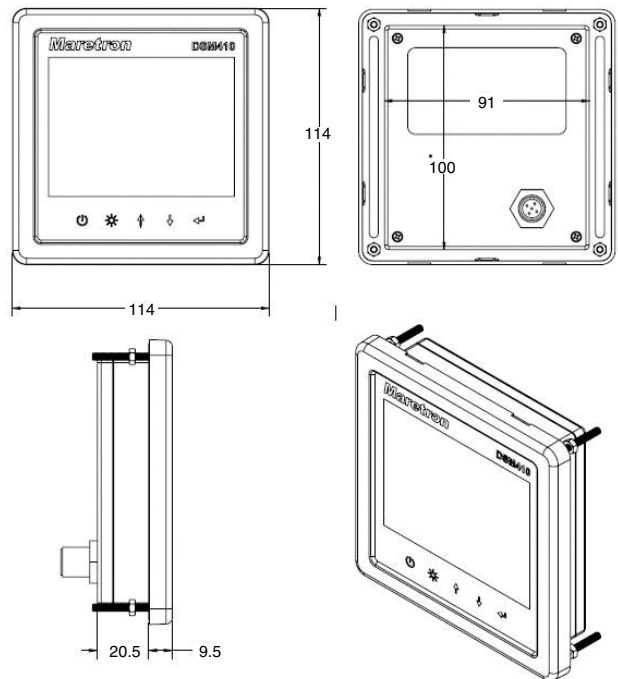
# DSM410

## 4.1" High Resolution Color Display

The DSM410 is a 4.1" high-resolution sunlight viewable color display that interprets and displays NMEA 2000® instrument, navigation, and vessel monitoring data. The DSM410 is a user-friendly dedicated marine display with custom screen configurations and an easy-to-use five-key illuminated keypad. In addition to the monitoring and display capabilities, the DSM410 features an alert/alarm package and electrical switching capability. Unlike traditional single-display units, DSM410 users can choose numeric, gauge, bar or graph formats in single or multiple displays with cycling options possible for a wide range of favorite data. These multiple display options conserve mounting space and reduce overall system cost. The DSM410 will directly connect with any NMEA 2000® network and with the exception of AIS data will display any or all information captured throughout the vessel. Various audio and visual alarms are also programmable. The DSM410 displays a multitude of information including AC power, anchor status, battery, depth, electrical distribution, engine, environment, fuel management, GPS, heading, navigation, pressure/vacuum, rudder, speed, status indicators, tanks, temperature, time, transmission, water makers, and more. Maretron's DSM410 is engineered and manufactured to the highest standards (IEC 60945 Maritime Navigation and Radiocommunication Equipment). Its compact waterproof housing will provide years of reliable performance. Dust cover included.



DSM410 Screen Shots



### PRODUCTS

PART NUMBER	DESCRIPTION
DSM410-01	4.1" High Resolution Color Display with Dust Cover
DSM410-Dust-Cover	

## SPECIFICATIONS

PARAMETER	VALUE	COMMENT
NMEA 2000® Connector	DeviceNet Micro-C	
Display Technology	Active Matrix TFT LCD	Sunlight Readable
Display Resolution	320 x 240 Pixels	QVGA Resolution
Display Viewable Area	82.56mm W x 61.92mm H	4.1" Diagonal
Display Backlighting	LED	3 User-Programmed Levels 0-100%
Body Construction	Anodized Aluminum	
Keyboard	5 Capacitive Touch Pads	LED Backlighting
Languages Supported	English, Dutch (Nederlands)	User Selectable

## SUPPORTED DATA DISPLAY TYPES

INSTRUMENT TYPE	DATA TYPES
AC Power	Average Frequency, Average L-N Voltage, Average L-L Voltage, Phase A Frequency, Phase A L-N Voltage, Phase AB L-L Voltage, Phase B Frequency, Phase B L-N Voltage, Phase BC L-L Voltage, Phase C Frequency, Phase C L-N Voltage, Phase CA L-L Voltage
Anchor	Watch
DC	Current, Voltage, Battery Temperature, Battery State of Charge, Battery Time Remaining, Ripple Voltage, Power
Depth	Water Depth, Water Below Transducer, Transducer Offset
Electrical	Resistance
Electrical Distribution	Switch/Breaker, Breaker Current, Hardware OFF Counter, Hardware ON Counter, Hardware ERROR Counter, Hardware ON Timer, Hardware OFF Timer, Hardware ERROR Timer
Engine Monitor	Boost Pressure, Hours, Coolant Pressure, Coolant Temp., Exhaust Gas Temp., Fuel Pressure, Fuel Rate, Oil Pressure, Oil Temp., Tachometer, Tilt/Trim, Voltage, Fuel Economy, Fuel Consumption, Percent Load, Percent Torque, Trip Fuel Used, Warning Indicators
Fluid Flow	Flow Rate, Trip Volume
Fuel Management	Distance to Empty, Time to Empty, Total Fuel Capacity, Total Fuel Level, Total Fuel Consumption, Total Trip Fuel Used, Total Fuel Economy, Total Fuel Rate, Total Fuel Remaining
GPS	COG, Lat/Lon, SOG, DOP, Satellites, Time, Accuracy
Heading	Heading, Rate of Turn, Variation
Humidity	Inside, Outside, User Defined
Indicator	Status, Hardware OFF Counter, Hardware ON Counter, Hardware ERROR Counter, Hardware ON Timer, Hardware OFF Timer, Hardware ERROR Timer
Mechanical	dB, Force, Strain
Motion	Acceleration, Angle, Angular Velocity, Angular Acceleration, Distance, Rotational Rate, Velocity
Navigation	BOD, BTW, COG, XTE, DTW, ETA, Lat/Lon, Rolling Road, Set/Drift, SOG, TTG, VMG, Waypoint Number & Name
Pressure/Vacuum	Altimeter, Barometric, Compressed Air, Engine Boost, Engine Coolant, Engine Fuel, Engine Oil, Hydraulic Oil, Steam, Transmission Oil, User Defined, Water
Rudder	Angle & Order
SMS	Status, Signal Strength, Indicator
Speed	Through Water, Over Ground, Total Log, Trip Log
Tanks	Capacity, Level, Remaining
Temperature	Bait Well, Battery, Engine Coolant, Engine Oil, Engine Room, Exhaust Gas, Freezer, Heat Index, Heating System, Inside, Live Well, Main Cabin, Outside, Refrigeration, Sea, Transmission Oil, User Defined, Wind Chill
Time	Local Date, UTC Date, Moon Phase, Sunrise, Sunset, Local Time, UTC Time, Twilight AM, Twilight PM
Transmission	Gear, Oil Pressure, Oil Temperature, Warning Indicators
Vessel	Heave, Pitch, Roll, Trim Tabs, Keel
Watermaker	Sea Recovery Status Display

## ELECTRICAL

PARAMETER	VALUE	COMMENT
Operating Voltage	9 to 30 Volts	DC Voltage
Power Consumption (Maximum)	250mA	
Load Equivalence Number (LEN)	1	NMEA 2000® Spec. (1LEN = 50mA)
Reverse Battery Protection	Yes	Indefinitely
Load Dump Protection	Yes	Energy Rated per SAE J1113

## ENVIRONMENTAL

PARAMETER	VALUE
IEC 60945	Exposed
Degree of Protection	IP67
Operating Temperature	-20°C to 70°C
Storage Temperature	-30°C to 80°C
Relative Humidity	93%RH @40° per IEC60945-8.2
Vibration	2-13.2Hz @ ±1mm, 13.2-100Hz @ 7m/s <sup>2</sup> per IEC 60945-8.
Rain and Spray	12.5mm Nozzle @ 100liters/min from 3m for 30min per IEC 60945-8.8
Solar Radiation	Ultraviolet B, A, Visible, and Infrared per IEC 60945-8.10
Corrosion (Salt Mist)	4 times 7 days @ 40°C, 95%RH after 2 hour Salt Spray Per IEC 60945-8.12
Electromagnetic Emission	Conducted and Radiated Emission per IEC60945-9
Electromagnetic Immunity	Conducted, Radiated, Supply, and ESD per IEC 60945-10
Safety Precautions	Dangerous Voltage, Electromagnetic Radio Frequency per IEC 60945-12

## MECHANICAL

PARAMETER	VALUE
Size	4.49" (H) x 4.49" (W) x 0.37" (Forward D) x 0.81" (Rear D) 114mm (H) x 114mm (W) x 9.5mm (Forward D) x 20.5mm (Rear D)
Weight	12.2 oz. (346 g)
Mounting	Flush Mount

## CERTIFICATIONS

PARAMETER	COMMENT
NMEA 2000® Standard	
Maritime Navigation and Radiocommunication Equipment & Systems	IEC 61162-3
Maritime Navigation and Radiocommunication Equipment & Systems	IEC 60945
FCC and CE Mark	Electromagnetic Compatibility



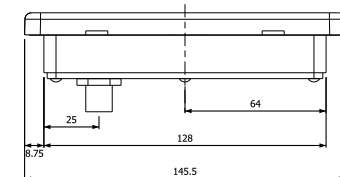
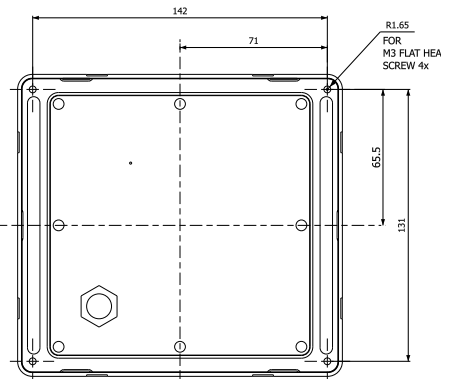
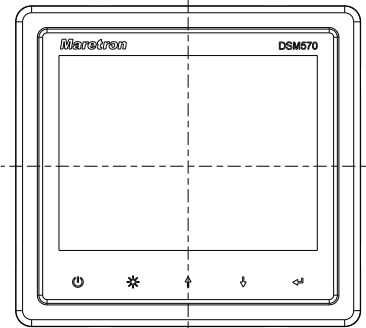
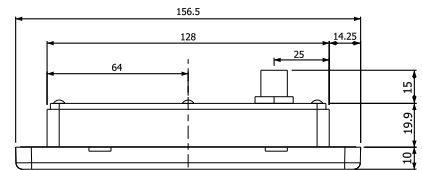
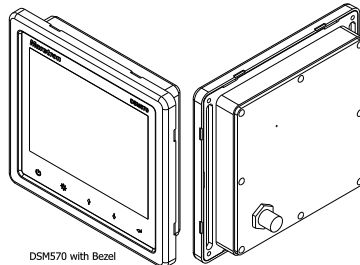
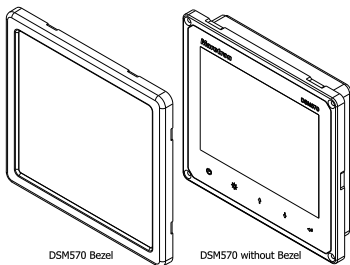
# DSM570

## 5.7" High Resolution Color Display

The DSM570 is a 5.7" high-resolution, sunlight viewable color display that interprets and displays NMEA 2000® instrument, navigation, and vessel monitoring data. The DSM570 is a user-friendly dedicated marine display with custom screen configurations and an easy-to-use five-key illuminated keypad. In addition to the monitoring and display capabilities, the DSM570 features an alert/alarm package and electrical switching capability. Unlike traditional single-display units, DSM570 users can choose numeric, gauge, bar or graph formats in single or multiple displays with cycling options possible for a wide range of favorite data. These multiple display options conserve mounting space and reduce overall system cost. The DSM570 will directly connect with any NMEA 2000® network and with the exception of AIS data will display any or all information captured throughout the vessel. Various audio and visual alarms are also programmable. The DSM570 displays a multitude of information including AC power, anchor status, battery, depth, electrical distribution, engine, environment, fuel management, GPS, heading, navigation, pressure/vacuum, rudder, speed, status indicators, tanks, temperature, time, transmission, water makers, and more. Maretron's DSM570 is engineered and manufactured to the highest standards (IEC 60945 Maritime Navigation and Radiocommunication Equipment). Its compact waterproof housing will provide years of reliable performance.

### Product Features

- CAN NMEA 2000® Communication
- Sunlight Viewable
- 16 User Defined Screens for Monitoring
- Alert/Alarm Package
- Electrical Switch Control
- Dust cover included



### PRODUCTS

PART NUMBER	DESCRIPTION
DSM570-01	5.7" High Resolution Color Display with Dust Cover
DSM570-Dust-Cover	

## SPECIFICATIONS

PARAMETER	VALUE	COMMENT
NMEA 2000® Connector	DeviceNet Micro-C	
Display Technology	Active Matrix TFT LCD	Sunlight Readable
Display Resolution	640 x 480 Pixels	QVGA Resolution
Display Viewable Area	115.2mm W x 86.4mm H	5.7" Diagonal
Display Backlighting	LED	3 User-Programmed Levels 0-100%
Body Construction	Anodized Aluminum	
Keyboard	5 Silicone Touch Pads	Multi-Colored LED Backlighting
Languages Supported	English, Dutch (Nederlands)	User Selectable

## SUPPORTED DATA DISPLAY TYPES

INSTRUMENT TYPE	DATA TYPES
AC Power	Average Frequency, Average L-N Voltage, Average L-L Voltage, Phase A Frequency, Phase A L-N Voltage, Phase AB L-L Voltage, Phase B Frequency, Phase B L-N Voltage, Phase BC L-L Voltage, Phase C Frequency, Phase C L-N Voltage, Phase CA L-L Voltage
Anchor	Watch
DC	Current, Voltage, Battery Temperature, Battery State of Charge, Battery Time Remaining, Ripple Voltage, Power
Depth	Water Depth, Water Below Transducer, Transducer Offset
Electrical	Resistance
Elec. Distribution	Switch/Breaker, Breaker Current, Hardware OFF Counter, Hardware ON Counter, Hardware ERROR Counter, Hardware ON Timer, Hardware OFF Timer, Hardware ERROR Timer
Engine Monitor	Boost Pressure, Hours, Coolant Pressure, Coolant Temp., Exhaust Gas Temp., Fuel Pressure, Fuel Rate, Oil Pressure, Oil Temp., Tachometer, Tilt/Trim, Voltage, Fuel Economy, Fuel Consumption, Percent Load, Percent Torque, Trip Fuel Used, Warning Indicators
Fluid Flow	Flow Rate, Trip Volume
Fuel Management	Distance to Empty, Time to Empty, Total Fuel Capacity, Total Fuel Level, Total Fuel Consumption, Total Trip Fuel Used, Total Fuel Economy, Total Fuel Rate, Total Fuel Remaining
GPS	COG, Lat/Lon, SOG, DOP, Satellites, Time, Accuracy
Heading	Heading, Rate of Turn, Variation
Humidity	Inside, Outside, User Defined
Indicator	Status, Hardware OFF Counter, Hardware ON Counter, Hardware ERROR Counter, Hardware ON Timer, Hardware OFF Timer, Hardware ERROR Timer
Mechanical	dB, Force, Strain
Motion	Acceleration, Angle, Angular Velocity, Angular Acceleration, Distance, Rotational Rate, Velocity
Navigation	BOD, BTW, COG, XTE, DTW, ETA, Lat/Lon, Rolling Road, Set/Drift, SOG, TTG, VMG, Waypoint Number & Name
Pressure/Vacuum	Altimeter, Barometric, Compressed Air, Engine Boost, Engine Coolant, Engine Fuel, Engine Oil, Hydraulic Oil, Steam, Transmission Oil, User Defined, Water
Rudder	Angle & Order
SMS	Status, Signal Strength, Indicator
Speed	Through Water, Over Ground, Total Log, Trip Log
Tanks	Capacity, Level, Remaining
Temperature	Bait Well, Battery, Engine Coolant, Engine Oil, Engine Room, Exhaust Gas, Freezer, Heat Index, Heating System, Inside, Live Well, Main Cabin, Outside, Refrigeration, Sea, Transmission Oil, User Defined, Wind Chill
Time	Local Date, UTC Date, Moon Phase, Sunrise, Sunset, Local Time, UTC Time, Twilight AM, Twilight PM
Transmission	Gear, Oil Pressure, Oil Temperature, Warning Indicators
Vessel	Heave, Pitch, Roll, Trim Tabs, Keel
Watermaker	Sea Recovery Status Display

## ELECTRICAL

PARAMETER	VALUE	COMMENT
Operating Voltage	9 to 30 Volts	DC Voltage
Power Consumption (Maximum)	4.5W	
Load Equivalence Number (LEN)	9	NMEA 2000® Spec. (1LEN = 50mA)
Reverse Battery Protection	Yes	Indefinitely
Load Dump Protection	Yes	Energy Rated per SAE J1113

## MECHANICAL

PARAMETER	VALUE
Size	5.77" (H) x 6.16" (W) x 0.37" (Forward D) x 0.81" (Rear D) 146.5mm (H) x 156.5 mm (W) x 10mm (Forward D) x 19.9mm (Rear D)
Weight	26 oz. (737g)
Mounting	Flush Mount

## ENVIRONMENTAL

PARAMETER	VALUE
IEC 60945	Exposed
Degree of Protection	IP67
Operating Temperature	-20°C to 70°C
Storage Temperature	-30°C to 80°C
Relative Humidity	93%RH @40° per IEC60945-8.2
Vibration	2-13.2Hz @ ±1mm, 13.2-100Hz @ 7m/s <sup>2</sup> per IEC 60945-8.
Rain and Spray	12.5mm Nozzle @ 100liters/min from 3m for 30min per IEC 60945-8.8
Solar Radiation	Ultraviolet B, A, Visible, and Infrared per IEC 60945-8.10
Corrosion (Salt Mist)	4 times 7 days @ 40°C, 95%RH after 2 hour Salt Spray Per IEC 60945-8.12
Electromagnetic Emission	Conducted and Radiated Emission per IEC60945-9
Electromagnetic Immunity	Conducted, Radiated, Supply, and ESD per IEC 60945-10
Safety Precautions	Dangerous Voltage, Electromagnetic Radio Frequency per IEC 60945-12

## CERTIFICATIONS

PARAMETER	COMMENT
NMEA 2000® Standard	
Maritime Navigation and Radiocommunication Equipment & Systems	IEC 61162-3
Maritime Navigation and Radiocommunication Equipment & Systems	IEC 60945
FCC and CE Mark	Electromagnetic Compatibility

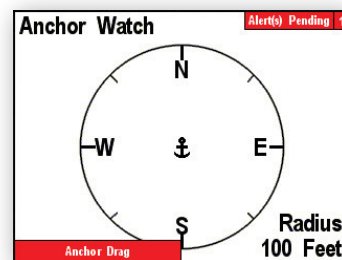
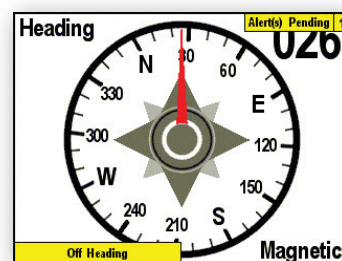
# ALM100

## Alarm Module

The Alarm Module generates visual and audible alerts for any monitored condition. The Alarm Module includes an extremely loud 105 dB SPL Piezoelectric sounder, along with a red high-brightness LED to indicate an alarm condition. A second green LED indicates that the Alarm Module is powered and ready to be triggered. The audible alarm can sound any one of 32 distinct pre-programmed patterns to indicate different alerts. The Alarm Module can be triggered by alarms generated by Maretron's N2KView® Vessel Monitoring Software, or by Maretron's Color Graphics Displays (DSM Series). The Alarm Module mounts in a standard electric box or can be flush mounted on any surface. Completely waterproof, the Alarm Module can be mounted inside or outside the vessel.

### Product Features

- NMEA 2000® Network Interface
- Super loud 105dB audible alarm
- Bright Red LED visual alarm
- Green LED status indicator
- Mount in standard electrical wall box or flush mount directly in wall
- 32 selectable alarm patterns
- Waterproof - can be mounted indoors or outdoors



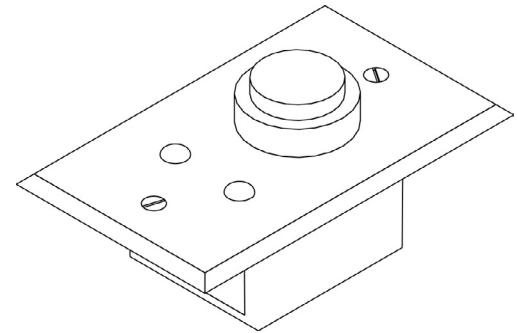
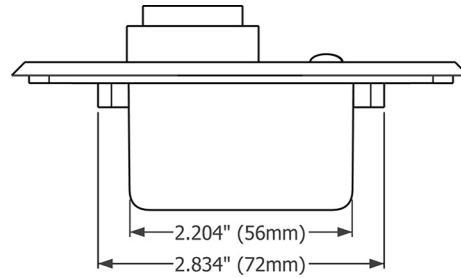
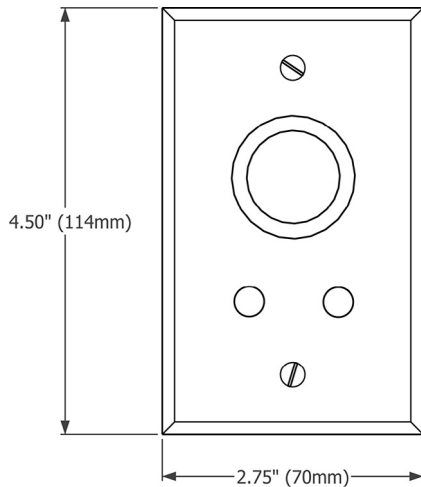
DSM Series Screen Shots

*ALM100 requires configuration if two or more exist on a single network (Maretron DSM Series, USB100, or IPG100 needed to configure)*

### PRODUCTS

PART NUMBER	DESCRIPTION
ALM100-01	Alarm Buzzer with Black Cover Plate
CP-BK-ALM100	ALM100 Black Cover Plate
CP-WH-ALM100	ALM100 White Cover Plate





## SPECIFICATIONS

PARAMETER	VALUE	COMMENT
Annunciator Volume	105 dB SPL	Mechanical Volume Control
Annunciator Frequency	2.9 kHz	

## NMEA 2000® PARAMETER GROUP NUMBERS (PGNs)

PARAMETER	PGN#	PGN NAME	DEFAULT RATE
Periodic Data PGNs	128720	Proprietary Alarm Status	1 time/second
	126464	PGN List (Transmit and Receive)	N/A
Response to Requested PGNs	126996	Product Information	N/A
	126998	Configuration Information	N/A
	059392	ISO Acknowledge	N/A
Protocol PGNs	059904	ISO Request	N/A
	060928	ISO Address Claim	N/A
	065240	ISO Address Command	N/A
	126720	NMEA Request/Command/Acknowledge	N/A
	126720	Device Configuration Information	N/A
Maretron Proprietary PGNs	130818	Device Label	N/A
	130824	Annunciator	1 time/second

## ELECTRICAL

PARAMETER	VALUE	COMMENT
Operating Voltage	9 to 32 Volts	DC Voltage
Power Consumption	100mA	NMEA 2000® Interface
Load Equivalence Number (LEN)	2	NMEA 2000® Spec. (1LEN = 50mA)
Reverse Battery Protection	Yes	Indefinitely
Load Dump Protection	Yes	Energy Rated per SAE J1113

## MECHANICAL

PARAMETER	VALUE	COMMENT
Size	2.75" x 4.50" x 2.00" (70mm x 114mm x 51mm)	Including wall plate – Mounts in standard single-gang electrical box
Weight	13 oz. (368.5g)	

## ENVIRONMENTAL

PARAMETER	VALUE
IEC 60945	Exposed
Degree of Protection	IP67
Operating Temperature	-25°C to 55°C
Storage Temperature	-40°C to 70°C
Relative Humidity	93%RH @40° per IEC60945-8.2
Vibration	2-13.2Hz @ ±1mm, 13.2-100Hz @ 7m/s² per IEC 60945-8.
Rain and Spray	12.5mm Nozzle @ 100liters/min from 3m for 30min per IEC 60945-8.8
Solar Radiation	Ultraviolet B, A, Visible, and Infrared per IEC 60945-8.10
Corrosion (Salt Mist)	4 times 7 days @ 40°C, 95%RH after 2 hour Salt Spray Per IEC 60945-8.12
Electromagnetic Emission	Conducted and Radiated Emission per IEC60945-9
Electromagnetic Immunity	Conducted, Radiated, Supply, and ESD per IEC 60945-10
Safety Precautions	Dangerous Voltage, Electromagnetic Radio Frequency per IEC 60945-12

## CERTIFICATIONS

PARAMETER	COMMENT
NMEA 2000® Standard	Level A
Maritime Navigation and Radio Communication Equipment & Systems	IEC 61162-3
Maritime Navigation and Radio Communication Equipment & Systems	IEC 60945
FCC and CE Mark	Electromagnetic Compatibility

# NMEA 2000® Gateways and Bridges

Although most of the Maretron vessel monitoring and control products are made to communicate across an NMEA 2000® network, there are times when it is appropriate to pass information over different communication protocols. Take for example the use of a computer or PC to monitor and control your vessel's systems. The PC doesn't have an NMEA 2000® connection, so a gateway like the Maretron USB100 is used to get information to

and from the computer. In addition to gateway products, Maretron offers a bridge for interconnecting two NMEA 2000® networks (NBE100). This allows you to expand an NMEA 2000® network beyond the normal limitation of 50 products up to 100 or even 250 products. You can even use the NBE100 to build redundant networks where safety is of utmost importance.



**USB100**

*NMEA 2000® to USB Gateway*



**IPG100**

*NMEA 2000® to Internet Protocol Gateway*



**J2K100**

*J1939 to NMEA 2000® Gateway*



**NBE100**

*NMEA 2000® Bridge (Network Bus Extender)*







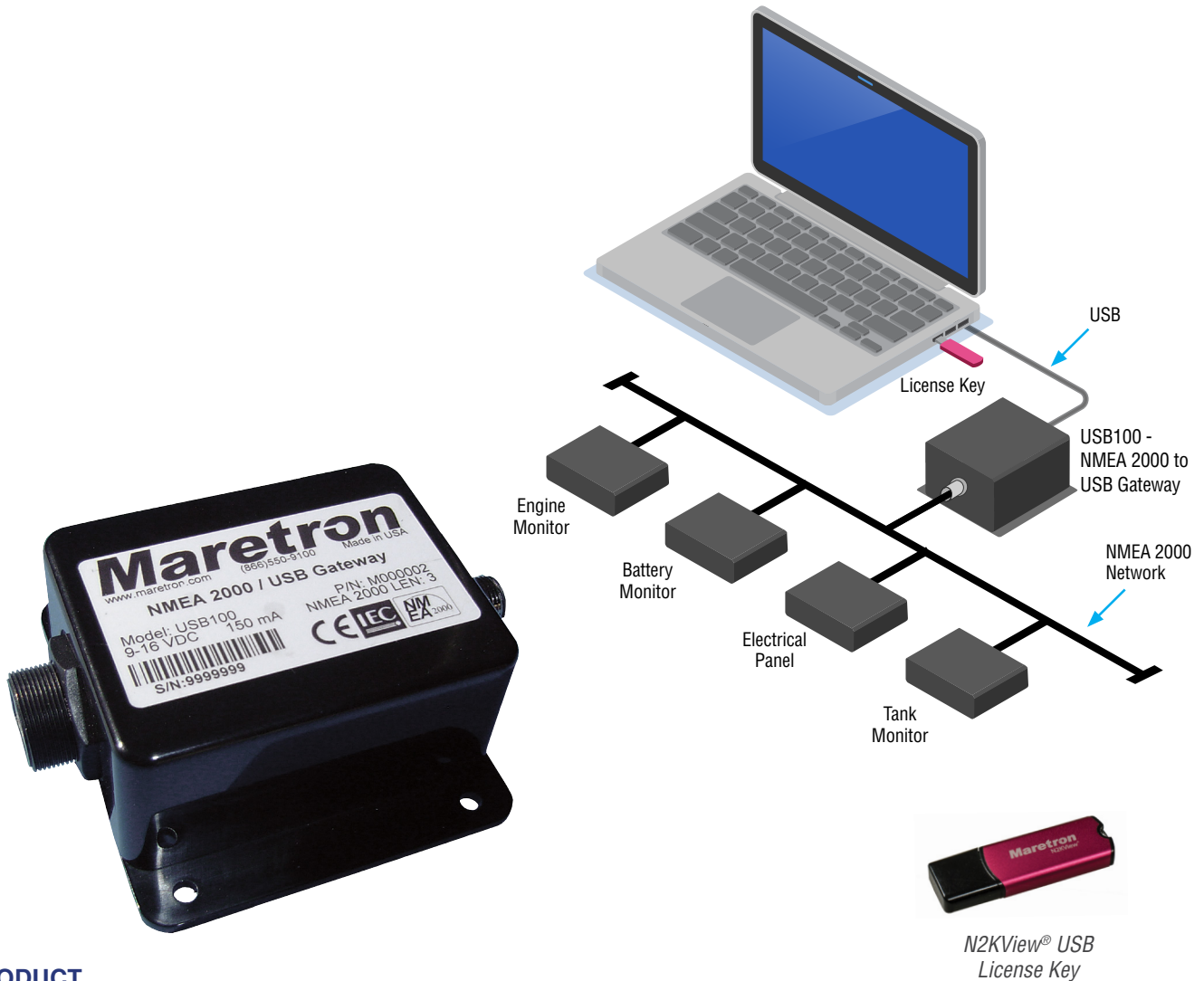
# USB100

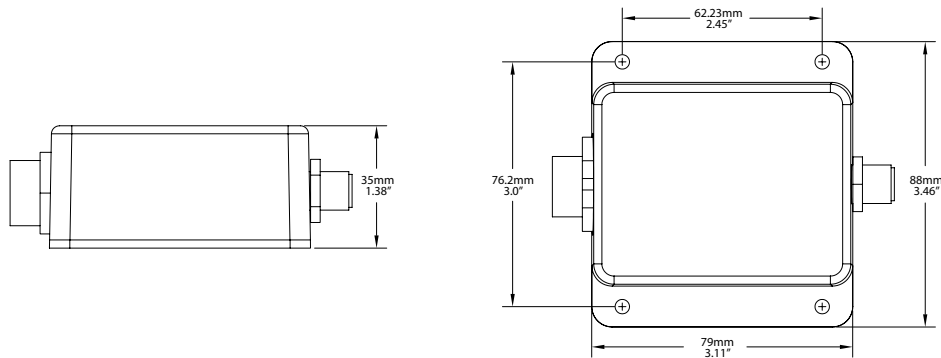
## NMEA 2000® to USB Gateway

Maretron's USB100 is a gateway for bridging computers to an NMEA network. This allows you to use PC based vessel monitoring and control software like Maretron's N2KView® or PC based navigation software. The gateway provides one simple connection between the network and the PC, which eliminates conventional multiplexers and the maze of wires usually associated with interfacing equipment to PCs.

For PC based navigation software that requires receiving data in NMEA 0183 format, the USB100 automatically converts information from the NMEA 2000® network to NMEA 0183 sentences. This allows you to continue benefiting from navigational and charting software that you already own while enjoying the many benefits of networked NMEA 2000® instruments.

Maretron's USB100 gateway is also used together with Maretron's N2KAnalyzer® software (page 133), which allows you to use a PC for configuring, updating, and troubleshooting products connected to an NMEA 2000® network. You can even save all of the vessel's product configurations and easily restore them if a product needs to be replaced.





## SPECIFICATIONS

PARAMETER	VALUE	COMMENT
NMEA 2000® Connector	DeviceNet Micro-C	Industry Standard Waterproof
NMEA 2000® / USB Isolation	Opto-Isolated	No Electrical Connection Across Bridge
USB Standard	USB 1.1	
USB Connector	USB Type B	Industry Standard Waterproof
USB Supported Signals	D+, D-, +5V, GND	Bi-directional Gateway
USB Auxiliary Power	+5 Volts < 50mA	
USB Baud Rate	Up to 12 Mb/s	Full Speed USB Data Rate
USB Interface Modes	NMEA 0183	With Maretron-Supplied Windows® Drivers
	Native NMEA 2000®	For Use With N2KView® and N2KAnalyzer
Supported Operating Systems	Windows XP, Vista, 7, 8, 10 and 11	

## TRANSLATED DATA TYPES (NMEA 2000® TO NMEA 0183)

INSTRUMENT TYPE	DATA TYPES
Battery Monitor	Voltage, Current, Temperature
Compass	Vessel Heading, Attitude, Rate of Turn
Depth	Water Depth, Transducer Offset
Engine	Standard Sentences: RPM. Proprietary Sentences: Boost Pressure, Tilt/Trim, Oil Pressure, Oil Temperature, Coolant Temperature, Alternator Potential, Fuel Rate, Total Engine Hours, Coolant Pressure, Fuel Pressure
GPS	COG, SOG, DOP, Position, Satellites, Time, Date
Rudder Indicator	Rudder Position
Speed	Distance Log, Speed
Weather Station	Water Temperature
Wind	Wind Direction and Speed

## ELECTRICAL

PARAMETER	VALUE	COMMENT
Operating Voltage	9 to 32 Volts	DC Voltage
Power Consumption	< 50mA	Average Current Drain
Load Equivalence Number (LEN)	1	NMEA 2000® Spec. (1LEN = 50mA)
Reverse Battery Protection	Yes	Indefinitely
Load Dump Protection	Yes	Energy Rated per SAE J1113

## MECHANICAL

PARAMETER	VALUE	COMMENT
Size	3.11" x 3.46" x 1.38" (79mm x 88mm x 35mm)	Including Flanges for Mounting
Weight	8 oz. (227 g)	

## ENVIRONMENTAL

PARAMETER	VALUE
IEC 60945 Classification	Exposed
Degree of Protection	IP67
Operating Temperature	-25°C to 55°C
Storage Temperature	-40°C to 70°C
Relative Humidity	93%RH @40° per IEC60945-8.2
Vibration	2-13.2Hz @ ±1mm, 13.2-100Hz @ 7m/s <sup>2</sup> per IEC 60945-8.
Rain and Spray	12.5mm Nozzle @ 100liters/min from 3m for 30min per IEC 60945-8.8
Solar Radiation	Ultraviolet B, A, Visible, and Infrared per IEC 60945-8.10
Corrosion (Salt Mist)	4 times 7 days @ 40°C, 95%RH after 2 hour Salt Spray Per IEC 60945-8.12
Electromagnetic Immunity	Conducted, Radiated, Supply, and ESD per IEC 60945-10
Safety Precautions	Dangerous Voltage, Electromagnetic Radio Frequency per IEC 60945-12

## CERTIFICATIONS

PARAMETER	COMMENT
NMEA 2000® Standard	Level A
Maritime Navigation and Radio Communication Equipment & Systems	IEC 61162-3
Maritime Navigation and Radio Communication Equipment & Systems	IEC 60945
FCC and CE Mark	Electromagnetic Compatibility

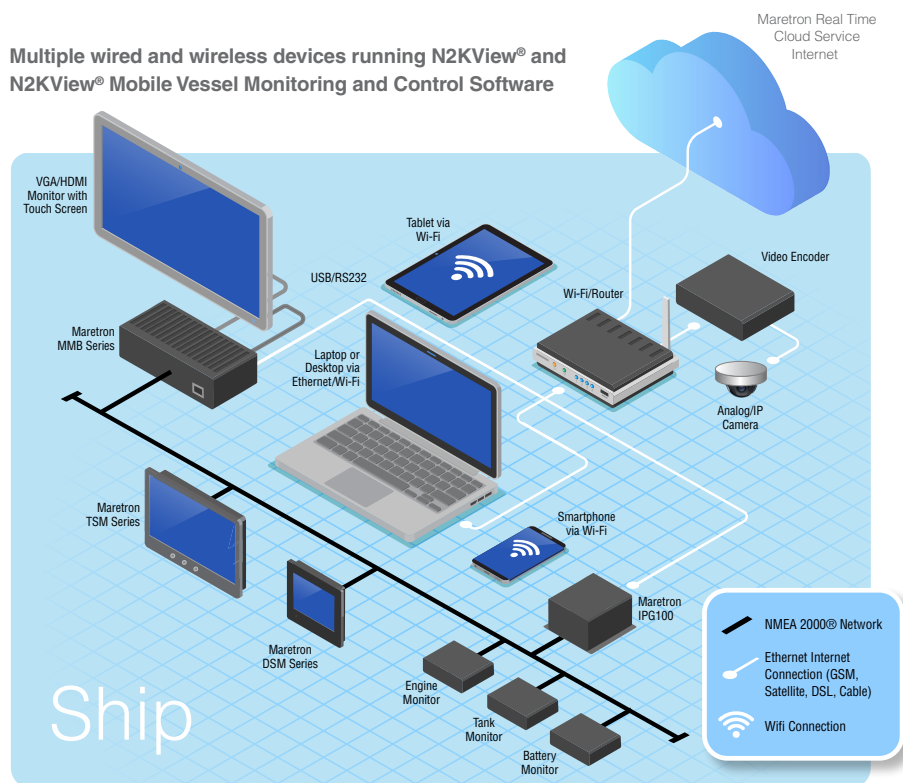
# IPG100

## NMEA 2000® to Internet Protocol Gateway

Connect your PC, Mac, tablet or smartphone to an NMEA 2000 network with the IPG100 Internet Protocol Gateway. Monitor and control your vessel's systems onboard and remotely using Maretron's N2KView® V3 software or Maretron's N2KView® Mobile App.

The IPG100 has an NMEA 2000 connector and an Ethernet data port for exchanging information between the onboard NMEA 2000 network and Internet Protocol (IP) enabled devices using conventional technology such as routers, switches, and wireless modems. Once enabled, the IPG100 will automatically connect to Maretron's Real Time Cloud Service (subscription required), allowing you to remotely connect to your vessel via the Internet. This allows you to keep an eye on your vessel from anywhere in the world.

Multiple wired and wireless devices running N2KView® and N2KView® Mobile Vessel Monitoring and Control Software



Available accessories for the IPG100:



PX0852



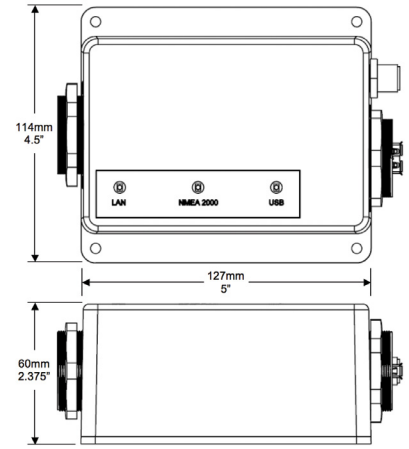
PX0837/5M00

### PRODUCTS

PART NUMBER	DESCRIPTION
IPG100-01	NMEA 2000® to Internet Protocol Gateway
PX0852	USB Waterproof Cover
PX0837/5M00	Waterproof Ethernet Cable 16.4'



Remote wired and wireless devices running N2KView® and N2KView® Mobile



**SPECIFICATIONS**

PARAMETER	VALUE	COMMENT
NMEA 2000® Connector	DeviceNet Micro-C	Industry Standard Waterproof
NMEA 2000® Isolation	Opto-Isolated	No Electrical Connection Across Bridge
USB Standard	USB 1.1	
USB Connector	USB Type A	Industry Standard Waterproof, for Connection of N2KView® Hardware License Key Only
USB Supported Signals	D+, D-, +5V, GND	Bi-directional Gateway
USB Auxiliary Power	+5 Volts < 200 mA	
USB Baud Rate	Up to 12 Mb/s	Full Speed USB Data Rate
Ethernet Interface	100 Mb/s	
Ethernet Connector	RJ-45	Industry Standard Waterproof

**NMEA 2000® PARAMETER GROUP NUMBERS (PGNs)**

DESCRIPTION	PGN#	PGN NAME	DEFAULT RATE
Response to Requested PGNs	126464	PGN List (Transmit and Receive)	N/A
	126996	Product Information	N/A
	126998	Configuration Information	N/A
Protocol PGNs	059392	ISO Acknowledge	N/A
	059904	ISO Request	N/A
	060416	ISO Transport Protocol, Connection Management	N/A
	060160	ISO Transport Protocol, Data Transfer	N/A
	060928	ISO Address Claim	N/A
	065240	ISO Address Command	N/A
	126208	NMEA Request/Command/Acknowledge	N/A
Maretron Proprietary PGNs	126720	Device Configuration Information	N/A
	130818	Device Label	N/A
	130832	Alert Operating Mode	N/A

**ELECTRICAL**

PARAMETER	VALUE	COMMENT
Operating Voltage	9 to 32 Volts	DC Voltage
Power Consumption	<150mA	Average Current Drain
Load Equivalence Number (LEN)	3	NMEA 2000® Spec. (1LEN = 50mA)
Reverse Battery Protection	Yes	Indefinitely
Load Dump Protection	Yes	Energy Rated per SAE J1113

**MECHANICAL**

PARAMETER	VALUE	COMMENT
Size	5.000" x 4.500" x 2.375" 127mm x 114mm x 60mm	Including Flanges for Mounting
Weight	12 oz. (340 g)	

**ENVIRONMENTAL**

PARAMETER	VALUE
IEC 60945 Classification	Exposed
Degree of Protection	IP67
Operating Temperature	-25°C to 55°C
Storage Temperature	-40°C to 70°C
Relative Humidity	93%RH @40° per IEC60945-8.2
Vibration	2-13.2Hz @ ±1mm, 13.2-100Hz @ 7m/s² per IEC 60945-8.7
Rain and Spray	12.5mm Nozzle @ 100liters/min from 3m for 30min per IEC 60945-8.8
Solar Radiation	Ultraviolet B, A, Visible, and Infrared per IEC 60945-8.10
Corrosion (Salt Mist)	4 times 7days @ 40°C, 95%RH after 2 hour Salt Spray Per IEC 60945-8.12
Electromagnetic Immunity	Conducted, Radiated, Supply, and ESD per IEC 60945-10
Safety Precautions	Dangerous Voltage, Electromagnetic Radio Frequency per IEC 60945-12

**CERTIFICATIONS**

PARAMETER	COMMENT
NMEA 2000® Standard	Level A
Maritime Navigation and Radio Communication Equipment & Systems	IEC 61162-3
Maritime Navigation and Radio Communication Equipment & Systems	IEC 60945
FCC and CE Mark	Electromagnetic Compatibility

# J2K100

## J1939 to NMEA 2000® Gateway

The J2K100 attaches directly into J1939 networks of compatible engines, transmissions and gensets and converts the J1939 data to the marine digital interface (NMEA 2000®). Critical engine, transmission, and genset data is then distributed throughout the vessel over a single cable where it can be monitored by any NMEA 2000® compatible display.

The J2K100 can also be used as part of a complete fuel computer. Simply connect the J2K100 together with Maretron universal displays (DSM Series, N2KView®) and GPS antenna/receiver (GPS200) and you have a system capable of displaying gallons per hour and/or miles per gallon.

### The J2K100 converts the following information:

- AC Generator Current
- AC Generator Frequency
- AC Generator Voltage
- Tachometer
- Engine Hours
- Coolant Pressure
- Coolant Water Temperature
- Dometic HVAC
- Dometic Icemaker
- Engine Oil Pressure
- Engine Oil Temperature
- Boost Pressure
- Fuel Rate Monitoring
- Charging Voltage
- Percent Engine Load
- Percent Engine Torque
- Rated Engine Speed
- VIN
- Software ID
- Transmission Gear
- Transmission Oil Pressure
- Transmission Oil Temperature



Available accessories for the J2K100:



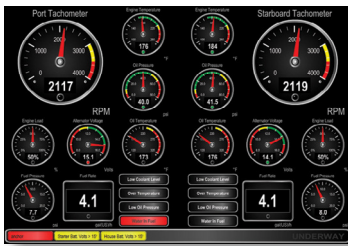
MCF-2M-D4



MCF-2M-D12



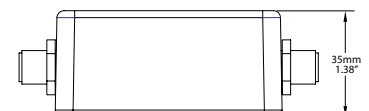
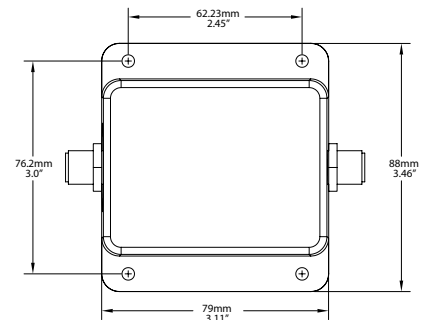
MCF-2M-D12CAT



N2KView® Engine Screen

Engine #0 Speed <b>2243</b> RPM	Total Fuel Rate <b>4.1</b> Gall/Hour
Engine #0 Fuel Rate <b>4.1</b> Gall/Hour	Total Fuel Economy <b>2.6</b> nm/Gallons

DSM Series Screen Shots



### PRODUCTS

PART NUMBER	DESCRIPTION
J2K100-01	J1939 to NMEA 2000® Gateway
MCF-2M-D4	J2K100 adapter Micro female to Deutsch 4 Pin 2 Meter Cordset
MCF-2M-D12	J2K100 adapter Micro female to Deutsch 12 Pin 2 Meter Cordset
MCF-2M-D12CAT	J2K100 adapter Micro female to Deutsch 12 Pin 2 T cable

## SPECIFICATIONS (J1939 Data Translated to NMEA 2000® Data)

J1939 SPN/PGN	DESCRIPTION	NMEA 2000® PGN
190 / 61444	Engine Speed	127488
102 / 65270	Engine Turbocharger Boost Pressure	127488
100 / 65263	Engine Oil Pressure	127489
175 / 65262	Engine Oil Temperature 1	127489
110 / 65262	Engine Coolant Temperature	127489
167 / 65271	Alternator Potential (Voltage)	127489
183 / 65266	Engine Fuel Rate	127489
247 / 65253	Engine Total Hours of Operation	127489
109 / 65263	Engine Coolant Pressure	127489
94 / 65263	Engine Fuel Delivery Pressure	127489
92 / 61443	Engine Percent Load at Current Speed	127489
513 / 61444	Actual Engine – Percent Torque	127489
189 / 65214	Engine Rated Speed	127498
237 / 65260	Vehicle Identification Number	127498
234 / 65242	Software Identification	127498
523 / 61445	Transmission Current Gear	127493
127 / 65272	Transmission Oil Pressure	127493
177 / 65272	Transmission Oil Temperature	127493

## CERTIFICATIONS

PARAMETER	COMMENT
NMEA 2000® Standard	Level B+
Maritime Navigation and Radio Communication Equipment & Systems	IEC 61162-3
Maritime Navigation and Radio Communication Equipment & Systems	IEC 60945
FCC and CE Mark	Electromagnetic Compatibility

## ELECTRICAL

PARAMETER	VALUE	COMMENT
Operating Voltage	9 to 32 Volts	DC Voltage
Power Consumption	< 150mA	Average Current Drain
Load Equivalence Number (LEN)	3	NMEA 2000® Spec. (1LEN = 50mA)
Reverse Battery Protection	Yes	Indefinitely
Load Dump Protection	Yes	Energy Rated per SAE J1113

## NMEA 2000® PARAMETER GROUP NUMBERS (PGNs)

DESCRIPTION	PGN#	PGN NAME	DEFAULT RATE
Periodic Data PGNs	127488	Engine Parameters, Rapid Update	10 times/second
	127489	Engine Parameters, Dynamic	1 time/second
	127498	Engine Parameters, Static	N/A
	127493	Transmission Parameters, Dynamic	10 times/second
	65030	J1939 Generator Average Basic AC Quantities	10 times/second
	65226	J1939 Diagnostic Message #1	N/A
	65227	J1939 Diagnostic Message #2	N/A
	65228	J1939 Diagnostic Message #3	N/A
	65229	J1939 Diagnostic Message #4	N/A
	65230	J1939 Diagnostic Message #5	N/A
	65231	J1939 Diagnostic Message #6	N/A
	65232	J1939 Diagnostic Message #8	N/A
	65234	J1939 Diagnostic Message #10	N/A
Response to Request PGNs	126464	PGN List (Transmit and Receive)	N/A
	126996	Product Information	N/A
	126998	Configuration Information	N/A
	059392	ISO Acknowledge	N/A
Protocol PGNs	059904	ISO Request	N/A
	060928	ISO Address Claim	N/A
	065240	ISO Address Command	N/A
	126208	NMEA Request/Command/Acknowledge	N/A
Maretron Proprietary PGNs	126720	Device Configuration Information	N/A
	130818	Device Label	N/A
	130828	Dometic HVAC Status	N/A
	130830	Dometic Icemaker Status	N/A

## MECHANICAL

PARAMETER	VALUE	COMMENT
Size	3.11" x 3.46" x 1.38" (79mm x 88mm x 35mm)	Including Flanges for Mounting
Weight	8 oz. (227 g)	

## ENVIRONMENTAL

PARAMETER	VALUE
IEC 60945 Classification	Exposed
Degree of Protection	IP67
Operating Temperature	-25°C to 55°C
Storage Temperature	-40°C to 70°C
Relative Humidity	93%RH @40° per IEC60945-8.2
Vibration	2-13.2Hz @ ±1mm, 13.2-100Hz @ 7m/s² per IEC 60945-8.7
Rain and Spray	12.5mm Nozzle @ 100liters/min from 3m for 30min per IEC 60945-8.8
Solar Radiation	Ultraviolet B, A, Visible, and Infrared per IEC 60945-8.10
Corrosion (Salt Mist)	4 times 7days @ 40°C, 95%RH after 2 hour Salt Spray Per IEC 60945-8.12
Electromagnetic Emission	Conducted, Radiated Emission per IEC 60945-9
Electromagnetic Immunity	Conducted, Radiated, Supply, and ESD per IEC 60945-10
Safety Precautions	Dangerous Voltage, Electromagnetic Radio Frequency per IEC 60945-12

**The J2K100 is compatible with any engine, transmission, or genset equipped with a J1939 interface, including products from the following manufacturers:**

- Caterpillar
- Cummins
- Detroit Diesel
- John Deere
- Kohler
- Northern Lights
- Onan
- Perkins
- Steyr
- Volvo Penta
- Yanmar



# NBE100

## NMEA 2000® Bridge (Network Bus Extender)

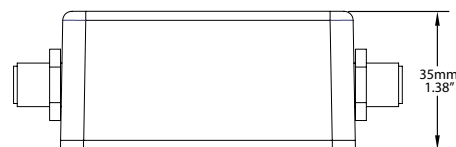
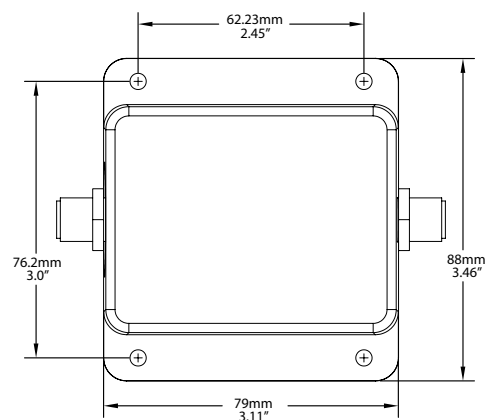
The Maretron NBE100 allows you to go beyond the maximum NMEA 2000® network design rules and extend an NMEA 2000 network to two, three, four, and even five times larger than normal. The NBE100 also solves problems associated with network errors and other electrical issues caused by exceeding NMEA 2000 rules and it simplifies the design of large networks.

NMEA 2000 network rules allow a maximum of 50 products connected on a single network, a maximum trunk length of 200 meters, and a maximum drop length of 78 meters. If you have a network that exceeds any of these specifications, you can simply extend the network trunk by inserting the NBE100, along with the additional termination resistors and powertaps. This will split the network into multiple electrical segments allowing 50 products per segment. The NBE100 will transparently route NMEA 2000 messages between multiple network segments, making them work as a single logical NMEA 2000 network.

Lastly, the NBE100 can be used to build redundant networks or isolate certain network segments so that if one segment is compromised, the other segments continue to operate.

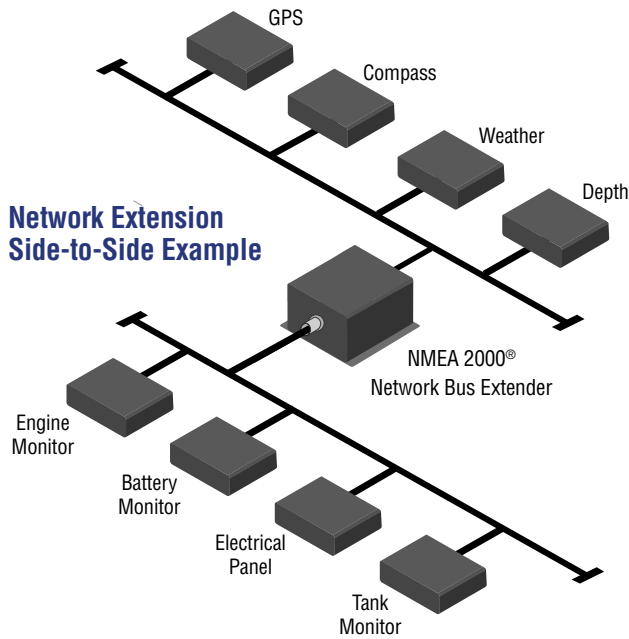
### Product Features

- Segments a single large NMEA 2000® network into smaller multiple electrical segments.
- Allows you to exceed the 50 product limitation on a NMEA 2000 network.
- Allows you to exceed the 200 meter trunk length limitation on a NMEA 2000 network.
- Allows you to exceed the 78 meter drop lengths limitation on a NMEA 2000 networks.
- Allows all NMEA 2000 devices to operate as if they were still on a single NMEA 2000 network.
- Optically isolates network segments, increasing signal integrity and network reliability.
- Allows filtering of NMEA 2000 PGNs by specifying PGN numbers to be passed or blocked.

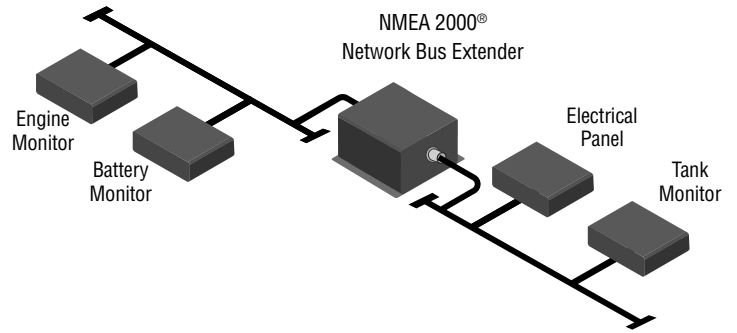


### PRODUCT

PART NUMBER	DESCRIPTION
NBE100-01	NMEA 2000® Bridge (Network Bus Extender)



### Network Extension End-to-End Example



### NMEA 2000® PARAMETER GROUP NUMBERS (PGNs)

DESCRIPTION	PGN#	PGN NAME	DEFAULT RATE
Response to Requested PGNs	126464	PGN List (Transmit and Receive)	N/A
	126996	Product Information	N/A
	126998	Configuration Information	N/A
Protocol PGNs	059392	ISO Acknowledge	N/A
	059904	ISO Request	N/A
	060928	ISO Address Claim	N/A
	065240	ISO Address Command	N/A
	126208	NMEA Request/Command/Acknowledge	N/A
Maretron Propriety PGNs	126720	Device Configuration Information	N/A
	130818	Device Label	N/A

### ELECTRICAL

PARAMETER	VALUE	COMMENT
Operating Voltage	9 to 32 Volts	DC Voltage
Power Consumption	< 150mA	Average Current Drain
Load Equivalence Number (LEN)	3	NMEA 2000® Spec. (1LEN = 50mA)
Reverse Battery Protection	Yes	Indefinitely
Load Dump Protection	Yes	Energy Rated per SAE J1113

### MECHANICAL

PARAMETER	VALUE	COMMENT
Size	3.11" x 3.46" x 1.38" (79mm x 88mm x 35mm)	Including Flanges for Mounting
Weight	8 oz. (227 g)	

### ENVIRONMENTAL

PARAMETER	VALUE
IEC 60945 Classification	Exposed
Degree of Protection	IP67
Operating Temperature	-25°C to 55°C
Storage Temperature	-40°C to 70°C
Relative Humidity	93%RH @40° per IEC60945-8.2
Vibration	2-13.2Hz @ ±1mm, 13.2-100Hz @ 7m/s² per IEC 60945-8.7
Rain and Spray	12.5mm Nozzle @ 100liters/min from 3m for 30min per IEC 60945-8.8
Solar Radiation	Ultraviolet B, A, Visible, and Infrared per IEC 60945-8.10
Corrosion (Salt Mist)	4 times 7days @ 40°C, 95%RH after 2 hour Salt Spray Per IEC 60945-8.12
Electromagnetic Emission	Conducted and Radiated Emission per IEC 60945-9
Electromagnetic Immunity	Conducted, Radiated, Supply, and ESD per IEC 60945-10
Safety Precautions	Dangerous Voltage, Electromagnetic Radio Frequency per IEC 60945-12

### CERTIFICATIONS

PARAMETER	COMMENT
NMEA 2000® Standard	Level A
Maritime Navigation and Radio Communication Equipment & Systems	IEC 61162-3
Maritime Navigation and Radio Communication Equipment & Systems	IEC 60945
FCC and CE Mark	Electromagnetic Compatibility

# Tank Monitoring

When it comes to tank monitoring, Maretron products offer the most comprehensive NMEA 2000® technology in the industry. Whether you're looking to retrofit a tank with an existing resistive sensor, or if you're interested in precision tank level even when heeled over during sailing or riding bow up on plane, we offer the right product for the application. All Maretron tank monitors can be custom calibrated for oddly shaped tanks providing unprecedented accuracy, especially when compared to

older analog gauge technologies. Maretron's tank monitors can even be programmed with the tank capacity so that multiple tanks can be combined into a single total tank gauge for display. You no longer have to mentally add up multiple tanks to figure how much water or fuel is onboard. Maretron user interface products will combine information from the tank monitors, fuel flow monitors, and GPS speed information to provide you with trip parameters like distance and time to empty.



**FPM100**  
*Fluid Pressure Monitor*



**TLM100**  
*Tank Level Monitor (Max 40" Depth)*



**TLM150**  
*Tank Level Monitor (Gasoline)*



**TLA100**  
*Tank Level Adapter*







# FPM100

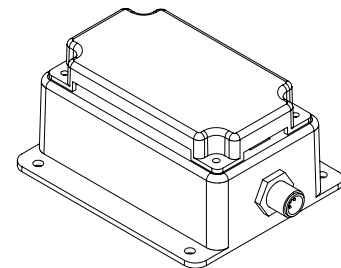
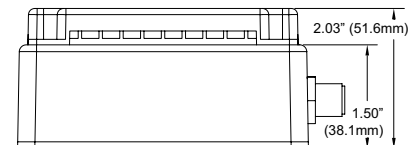
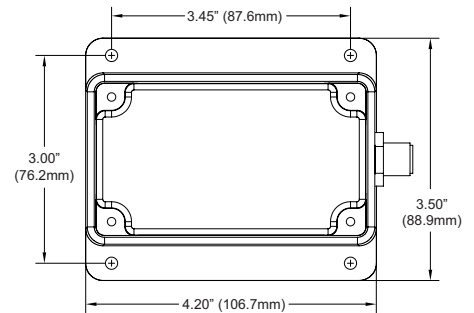
## Fluid Pressure Monitor

The Fluid Pressure Monitor is used to interface up to six pressure transducers to the NMEA 2000® network (pressure transducers sold separately). This allows you to observe fluid pressures and tank levels anywhere on the vessel where there are NMEA 2000 compatible displays. With the appropriate transducer, the FPM100 reports either pressure or vacuum for a variety of applications including water pressures, oil pressures, hydraulic pressures, or system vacuum for detecting clogged filters.

The FPM100 also has a tank level mode, so that fluid levels in a tank can be monitored via a pressure transducer mounted at the bottom of the tank and transmitted over the NMEA 2000 network. This allows you to monitor the fluid levels in tanks that are extremely deep, have internal structures, or are otherwise not suited for other tank level sensing technologies. In this mode, the FPM100 can be calibrated for irregular tank shapes so that you know the true level of the tanks.

### Product Features

- NMEA 2000® interface
- Interfaces up to six pressure transducers to the NMEA 2000 network
- Each channel independently programmable to match pressure transducer characteristics
- Each channel independently programmable in pressure/vacuum mode or tank level mode



### PRODUCTS

PART NUMBER	DESCRIPTION
FPM100-01	Fluid Pressure Monitor
PT-0-1.5PSI-01	Pressure Transducer 0 to 1.5 PSI
PT-0-3PSI-01	Pressure Transducer 0 to 3 PSI
PT-0-5PSI-01	Pressure Transducer 0 to 5 PSI
PT-0-10PSI-01	Pressure Transducer 0 to 10 PSI
PT-0-50PSI-01	Pressure Transducer 0 to 50 PSI
PT-0-100PSI-01	Pressure Transducer 0 to 100 PSI
PT-0-300PSI-01	Pressure Transducer 0 to 300 PSI

PART NUMBER	DESCRIPTION
PT-0-500PSI-01	Pressure Transducer 0 to 500 PSI
PT-0-1000PSI-01	Pressure Transducer 0 to 1000 PSI
PT-0-5000PSI-01	Pressure Transducer 0 to 5000 PSI
PT-SNUB-01	Pressure Snubber
PT-V-0-1BAR-01	Pressure Transducer Vacuum to 1 Bar
PTS-0-1.5PSI-01	Submersible Pressure Transducer 0 to 1.5 PSI
PTS-0-3.0PSI-01	Submersible Pressure Transducer 0 to 3.0 PSI
PTS-0-5PSI-01	Submersible Pressure Transducer 0 to 5 PSI

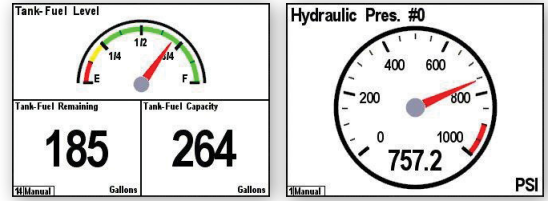
Available accessories for the FPM100:



PT-0-xxxxPSI-01



PTS-0-x.xPSI-01



DSM Series Screen Shots

**SPECIFICATIONS (PRESSURE/VACUUM MODE)**

PARAMETER	VALUE	COMMENT
Accuracy	+/-1% FS	Exclusive of Pressure Transducer
Resolution	+/-0.33% FS	Over Full Pressure Transducer Range
Number of Pressure Source Types	21	Water Pressure, Atmospheric Pressure, Compressed Air Pressure, Hydraulic Pressure, Steam Pressure, 16 User Defined Sources

**SPECIFICATIONS (TANK LEVEL MODE)**

PARAMETER	VALUE	COMMENT
Accuracy	+/-1% FS	Exclusive of Pressure Transducer
Resolution	+/-0.33% FS	Over Full Pressure Transducer Range
Number of Tank Types	16	Fuel, Fresh Water, Waste water, Live well, Oil, etc.
Number of Tanks per Tank Type	16	16 Tanks per Tank Type Numbered 0 –15
Support for Irregularly Shaped Tanks	Yes	Can be Calibrated for any Shape Tank
Programmable Tank Capacity	Yes	Allows Displays to Calculate Amount Remaining
Support for Irregularly Shaped Tanks	Yes	Can be Calibrated for any Shape Tank
Programmable Tank Capacity	Yes	Allows Displays to Calculate Amount Remaining

**NMEA 2000® PARAMETER GROUP NUMBERS (PGNs)**

DESCRIPTION	PGN#	PGN NAME	DEFAULT RATE
Periodic Data PGNs	127505	Fluid Level	0.4 Times/Second
	130314	Actual Pressure	0.5 Times/Second
Response to Requested PGNs	126464	PGN List (Transmit and Receive)	N/A
	126996	Product Information	N/A
	126998	Configuration Information	N/A
Protocol PGNs	059392	ISO Acknowledge	N/A
	059904	ISO Request	N/A
	060928	ISO Address Claim	N/A
	065240	ISO Address Command	N/A
	126208	NMEA Request/Command/Acknowledge	N/A
	126720	Device Configuration Information	N/A
Maretron Proprietary PGNs	130818	Device Label	N/A

**ELECTRICAL**

PARAMETER	VALUE	COMMENT
Operating Voltage	9 to 32 Volts	DC Voltage
Power Consumption	400mA	Maximum Current Drain
Load Equivalence Number (LEN)	8	NMEA 2000® Spec. (1LEN = 50mA)
Reverse Battery Protection	Yes	Indefinitely
Load Dump Protection	Yes	Energy Rated per SAE J1113

**MECHANICAL**

PARAMETER	VALUE	COMMENT
Size	3.50" x 4.20" x 2.03" 88.9mm x 106.7mm x 51.6mm	Including Flanges for Mounting
Weight	13 oz. (368.5 g)	

**ENVIRONMENTAL**

PARAMETER	VALUE
IEC 60945 Classification	Exposed
Degree of Protection	IP64
Operating Temperature	-25°C to 55°C
Storage Temperature	-40°C to 70°C
Relative Humidity	93%RH @40° per IEC60945-8.2
Vibration	2-13.2Hz @ ±1mm, 13.2-100Hz @ 7m/s² per IEC 60945-8.7
Rain and Spray	12.5mm Nozzle @ 100liters/min from 3m for 30min per IEC 60945-8.8
Solar Radiation	Ultraviolet B, A, Visible, and Infrared per IEC 60945-8.10
Corrosion (Salt Mist)	4 times 7days @ 40°C, 95%RH after 2 hour Salt Spray Per IEC 60945-8.12
Electromagnetic Emission	Conducted and Radiated Emission per IEC 60945-9
Electromagnetic Immunity	Conducted, Radiated, Supply, and ESD per IEC 60945-10
Safety Precautions	Dangerous Voltage, Electromagnetic Radio Frequency per IEC 60945-12

**CERTIFICATIONS**

PARAMETER	COMMENT
NMEA 2000® Standard	Level A
Maritime Navigation and Radio Communication Equipment & Systems	IEC 61162-3
Maritime Navigation and Radio Communication Equipment & Systems	Tested to IEC 60945
FCC and CE Mark	Electromagnetic Compatibility



# TLM100

## Tank Level Monitor (40" Max Depth)

The TLM100 is used to sense fluid levels of tanks by using ultrasonic technology. Ultrasonic sound waves are transmitted via the TLM100 mounted at the top of the tank and the flight times of the sound waves to and from the fluid are measured much like a depth sensor. What this means for you is that there are no difficult to handle long probes protruding into the tank, which often foul and/or corrode. Once the TLM100 calculates and transmits the fluid level over the NMEA 2000® network, you can observe tank levels anywhere on the vessel where there is an NMEA 2000® compatible display such as the Maretron DSM Series.

The TLM100 is capable of sensing fluid levels in tanks up to 40" (1.02m) in depth. It can be used for diesel, fresh water, waste water, black water, and oil tanks (see TLM150 for gasoline tanks or the FPM100 for deeper tanks). Unlike most tank senders that only work with rectangular tanks, the TLM100 can be calibrated for irregular tank shapes so you can know the true fluid level in your tanks.

The TLM100 is mounted directly to the top of tanks using the industry standard SAE J1810 5-hole mounting pattern. The TLM100 can also be mounted

to tanks with threaded tank openings using optional adapters that include both a 1.5" NPT and a 1.25" BSP adapter. There are other important TLM100 optional accessories including an optional focus tube to permit use on boats with planing hulls, which is required if the vessel spends a significant amount of time with the bow pitched up.

Most importantly, the TLM100 is NMEA 2000 certified so you can view any and all tank levels anywhere on the vessel when using a compatible NMEA 2000 display. The TLM100 is another key component of Maretron's N2KView® vessel monitoring and control system.



Available accessories for the TLM100:



TA-5H-x



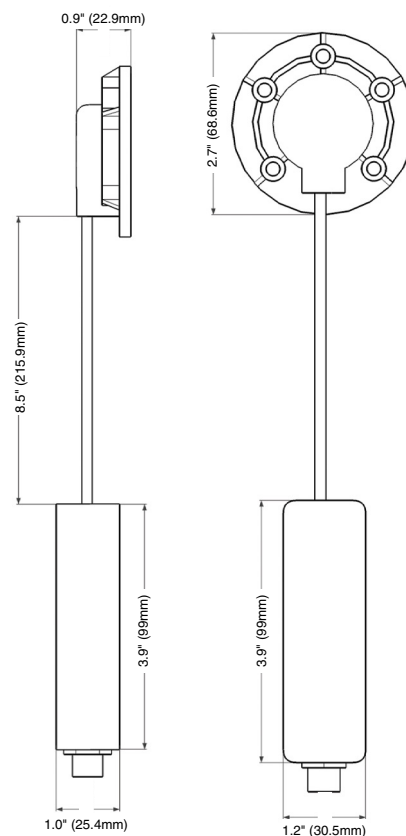
TFT-5H



TFT-x

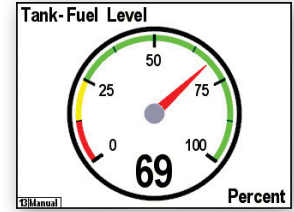
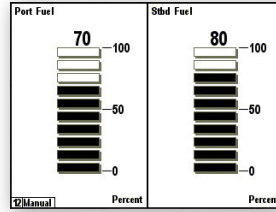
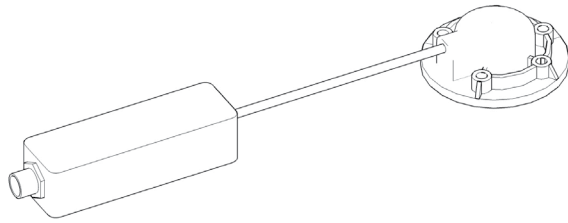


TFTDBE-5H



### PRODUCTS

PART NUMBER	DESCRIPTION
TLM100-01	Tank Level Monitor (40" Max Depth)
TA-5H-1.25BSP	1.25" BSP Displacement Hull Tank Adapter
TA-5H-1.5NPT	1.5" NPT Displacement Hull Tank Adapter
TFT-5H	SAE 5-Bolt Pattern Non-Displacement Hull Focus Tube
TFT-1.25BSP	1.25" BSP Non-Displacement Hull Focus Tube
TFT-1.5NPT	1.5" NPT Non-Displacement Hull Focus Tube
TFTDBE-5H	5-Bolt Pattern Focus Tube with Dead Band Eliminator



DSM Series Screen Shots

## SPECIFICATIONS

PARAMETER	VALUE	COMMENT
Accuracy	+/-2%	
Resolution	+/-1%	
Number of Tank Types	16	Fuel, fresh water, waste water, live well, oil, etc.
Number of Tanks per Tank Type	16	16 tanks per tank type numbered 0-15
Maximum Tank Depth	40" (1.02m)	
Minimum Depth Reading	2" (5.08cm)	Sensor deadband
Support for Irregularly Shaped Tanks	Yes	Can be calibrated for any shape tank
Programmable Tank Capacity	Yes	Allows displays to calculate amount remaining
Maximum Tank Angle	6°	Without focus tube
	15°	With focus tube

## NMEA 2000® PARAMETER GROUP NUMBERS (PGNs)

DESCRIPTION	PGN#	PGN NAME	DEFAULT RATE
Periodic Data PGNs	127505	Fluid Level	0.4 times/second
Response to Requested PGNs	126464	PGN List (Transmit and Receive)	N/A
	126996	Product Information	N/A
Protocol PGNs	126998	Configuration Information	N/A
	059392	ISO Acknowledge	N/A
	059904	ISO Request	N/A
	060928	ISO Address Claim	N/A
	065240	ISO Address Command	N/A
	126208	NMEA Request/Command/Acknowledge	N/A
Maretron Proprietary PGNs	126720	Device Configuration Information	N/A
	130818	Device Label	N/A

## ELECTRICAL

PARAMETER	VALUE	COMMENT
Operating Voltage	9 to 16 Volts	DC Voltage
Power Consumption	<100mA	Average Current Drain
Load Equivalence Number (LEN)	2	NMEA 2000® Spec. (1LEN = 50mA)
Reverse Battery Protection	Yes	Indefinitely
Load Dump Protection	Yes	Energy Rated per SAE J1113

## MECHANICAL

PARAMETER	VALUE	COMMENT
Size	3.9" x 1.2" x 1.0" (99mm x 30.5mm x 25.4mm)	Interface Component
	2.7" dia. x 0.9" (68.6mm dia. x 22.9)	Sensor Component
	8.5" (215.9mm)	Interconnecting Cable
Weight	12 oz. (340 g)	
Mounting	SAE J1810 5-hole bolt pattern	Can mount to 1.25" BSP or 1.5" NPT using available adapters

## ENVIRONMENTAL

PARAMETER	VALUE
IEC 60945 Classification	Exposed
Degree of Protection	IP67
Operating Temperature	-25°C to 55°C
Storage Temperature	-40°C to 70°C
Relative Humidity	93%RH @40° per IEC60945-8.2
Vibration	2-13.2Hz @ ±1mm, 13.2-100Hz @ 7m/s² per IEC 60945-8.7
Rain and Spray	12.5mm Nozzle @ 100liters/min from 3m for 30min per IEC 60945-8.8
Solar Radiation	Ultraviolet B, A, Visible, and Infrared per IEC 60945-8.10
Corrosion (Salt Mist)	4 times 7days @ 40°C, 95%RH after 2 hour Salt Spray Per IEC 60945-8.12
Electromagnetic Emission	Conducted and Radiated Emission per IEC 60945-9
Electromagnetic Immunity	Conducted, Radiated, Supply, and ESD per IEC 60945-10
Safety Precautions	Dangerous Voltage, Electromagnetic Radio Frequency per IEC 60945-12

## CERTIFICATIONS

PARAMETER	COMMENT
NMEA 2000®	Level B
Maritime Navigation and Radio Communication Equipment & Systems	Tested to IEC 60945
FCC and CE Mark	Electromagnetic Compatibility

# TLM150

## Tank Level Monitor (Gasoline)

The TLM150 is used to sense gasoline fluid levels of tanks using ultrasonic technology. Ultrasonic, or sound waves, are transmitted via the TLM150 mounted at the top of the tank and the flight times of the sound waves to and from the fluid are measured much like a depth sensor. What this means for you is that there are no difficult to handle long probes protruding into the tank, which often foul and/or corrode. Once the TLM150 calculates and broadcast the fluid level over the NMEA 2000® network, you can observe tank levels anywhere on the vessel where there is an NMEA 2000® compatible display such as the Maretron DSM Series.

The TLM150 is capable of sensing gasoline levels in tanks up to 24" (0.61m) in depth (see TLM100 for fluid types other than gasoline). Unlike most tank senders that only work with rectangular tanks, the TLM150 can be calibrated for irregular tank shapes so you can know the true fluid level in your tanks.

The TLM150 is mounted directly to the top of tanks using the industry standard SAE J1810 5-hole mounting pattern. The TLM150 can also be mounted to tanks with threaded tank openings using optional adapters that include both a 1.5" NPT and a 1.25" BSP adapter. The other important optional accessory

for the TLM150 is the focus tube to permit use on boats with planing hulls, which is required if the vessel spends a significant amount of time with the bow pitched up.

Most importantly, the TLM150 is NMEA 2000® certified so you can view any and all tank levels anywhere on the vessel when using a compatible NMEA 2000® display. The TLM150 is another key component of Maretron's N2KView® vessel monitoring and control system.



Available accessories for the TLM150:



TA-5H-x



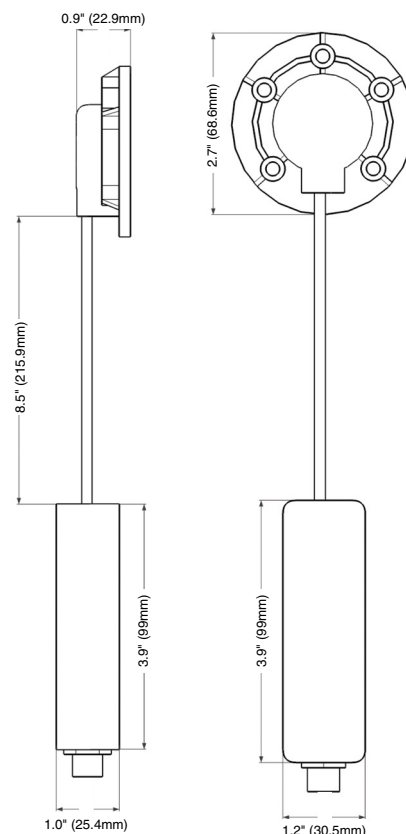
TFT-5H



TFT-x



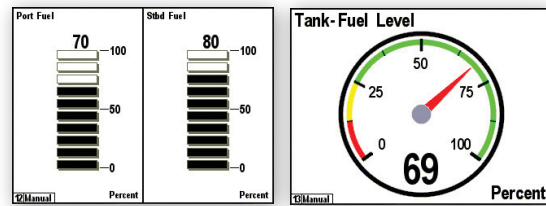
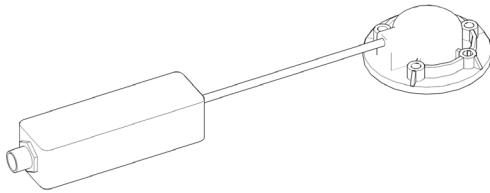
TFTDBE-5H



### PRODUCTS

PART NUMBER	DESCRIPTION
TLM150-01	Tank Level Monitor (24" Depth Gasoline Tanks)
TA-5H-1.25BSP	1.25" BSP Displacement Hull Tank Adapter
TA-5H-1.5NPT	1.5" NPT Displacement Hull Tank Adapter
TFT-5H	SAE 5-Bolt Pattern Non-Displacement Hull Focus Tube
TFT-1.25BSP	1.25" BSP Non-Displacement Hull Focus Tube
TFT-1.5NPT	1.5" NPT Non-Displacement Hull Focus Tube
TFTDBE-5H	5-Bolt Pattern Focus Tube with Dead Band Eliminator





DSM Series Screen Shots

## SPECIFICATIONS

PARAMETER	VALUE	COMMENT
Accuracy	+/-2%	
Resolution	+/-1%	
Number of Tank Types	1	Fuel (Gasoline only)
Number of Tanks per Tank Type	16	16 Tanks per Tank Type Numbered 0 –15
Maximum Tank Depth	24" (.61m)	
Minimum Depth Reading	2" (5.08cm)	Sensor Deadband
Support for Irregularly Shaped Tanks	Yes	Can be Calibrated for any Shape Tank
Programmable Tank Capacity	Yes	Allows Displays to Calculate Amount Remaining
Maximum Tank Angle	6°	Without focus tube
	15°	With focus tube

## NMEA 2000® PARAMETER GROUP NUMBERS (PGNs)

DESCRIPTION	PGN#	PGN NAME	DEFAULT RATE
Periodic Data PGNs	127505	Fluid Level	0.4 times/second
	126464	PGN List (Transmit and Receive)	N/A
Response to Requested PGNs	126996	Product Information	N/A
	126998	Configuration Information	N/A
	059392	ISO Acknowledge	N/A
Protocol PGNs	059904	ISO Request	N/A
	060928	ISO Address Claim	N/A
	065240	ISO Address Command	N/A
	126208	NMEA Request/Command/Acknowledge	N/A

## ELECTRICAL

PARAMETER	VALUE	COMMENT
Operating Voltage	9 to 16 Volts	DC Voltage
Power Consumption	<100mA	Average Current Drain
Load Equivalence Number (LEN)	2	NMEA 2000® Spec. (1LEN = 50mA)
Reverse Battery Protection	Yes	Indefinitely
Load Dump Protection	Yes	Energy Rated per SAE J1113

## MECHANICAL

PARAMETER	VALUE	COMMENT
Size	3.9" x 1.2" x 1.0" (99mm x 30.5mm x 25.4mm)	Interface Component
	2.7" dia. x 0.9" (68.6mm dia. x 22.9)	Sensor Component
	8.5" (215.9mm)	Interconnecting Cable
Weight	12 oz. (340 g)	
Mounting	SAE J1810 5-hole bolt pattern	Can mount to 1.25" BSP or 1.5" NPT using available adapters

## ENVIRONMENTAL

PARAMETER	VALUE
IEC 60945 Classification	Exposed
Degree of Protection	IP67
Operating Temperature	-25°C to 55°C
Storage Temperature	-40°C to 70°C
Relative Humidity	93%RH @40° per IEC60945-8.2
Vibration	2-13.2Hz @ ±1mm, 13.2-100Hz @ 7m/s² per IEC 60945-8.7
Rain and Spray	12.5mm Nozzle @ 100liters/min from 3m for 30min per IEC 60945-8.8
Solar Radiation	Ultraviolet B, A, Visible, and Infrared per IEC 60945-8.10
Corrosion (Salt Mist)	4 times 7days @ 40°C, 95%RH after 2 hour Salt Spray Per IEC 60945-8.12
Electromagnetic Emission	Conducted and Radiated Emission per IEC 60945-9
Electromagnetic Immunity	Conducted, Radiated, Supply, and ESD per IEC 60945-10
Safety Precautions	Dangerous Voltage, Electromagnetic Radio Frequency per IEC 60945-12

## CERTIFICATIONS

PARAMETER	COMMENT
NMEA 2000®	Level B
Maritime Navigation and Radio Communication Equipment & Systems	Tested to IEC 60945
FCC and CE Mark	Electromagnetic Compatibility

# TLA100

## Tank Level Adapter

The TLA100 is used to adapt commercially available resistive tank senders to the NMEA 2000® network. This allows you to observe tank levels anywhere on the vessel where there are NMEA 2000 compatible displays such as the Maretron DSM Series.

The TLA100 is compatible with both the American standard (240-30 ohm) and the European standard (10-180 ohm) resistive senders. In fact, the TLA100 can be calibrated for any resistance between 0 and 300 ohms.

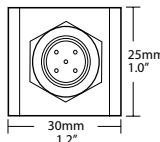
Unlike most tank senders that only work with rectangular tanks, the TLA100 can be calibrated for irregular tank shapes so you know the true level of the tanks. You can also use the TLA100 with analog gauges at the same time as NMEA 2000 so you don't have to give up existing analog gauges to enjoy the advantages of digitally networked information.

### Product Features

- NMEA 2000® Interface
- Adapts American Standard (240-30 ohm) resistive senders to NMEA 2000 Network
- Adapts European standard (10-180 ohm) resistive senders to NMEA 2000 Network
- Can be user calibrated for any resistance range from 0 to 300 Ohms or 300 to 0 Ohms
- Accommodates irregularly shaped tanks with 16 Point calibration
- 16 Programmable tank types including fuel, fresh water, waste water, live well
- Programmable tank number(s) up to 16 per tank type
- Programmable tank capacity
- Works alongside of analog gauges
- Can be used standalone without analog gauges



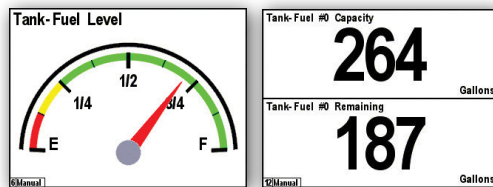
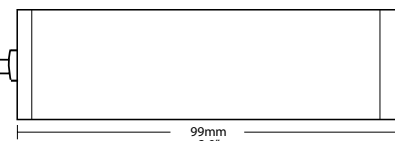
End View



Top View



Side View



DSM Series Screen Shots

### PRODUCT

PART NUMBER	DESCRIPTION
TLA100-01	Tank Level Adapter

## SPECIFICATIONS

PARAMETER	VALUE	COMMENT
Accuracy	+/-2%	Does Not Include Inaccuracies of Analog Gauge or Sender
Resolution	+/-1%	Worst Case (Resolution better at high resistance valves)
Number of Tank Types	16	Fuel, fresh water, waste water, live well, oil, etc.
Number of Tanks per Tank Type	16	16 Tanks per Tank Type Numbered 0 –15
American Standard Senders	240–30 ohms	Standard Sender Types are User Selectable
European Standard Senders	10–180 ohms	Standard Sender Types are User Selectable
Calibration Resistance Range	0–300 ohms	Non-Standard Sender Calibration
Support for Irregularly Shaped Tanks	Yes	Can be Calibrated for any Shape Tank
Programmable Tank Capacity	Yes	Allows Displays to Calculate Amount Remaining
Analog Gauge Support	Yes	Can be Used With or Without Analog Gauge

## NMEA 2000® PARAMETER GROUP NUMBERS (PGNs)

DESCRIPTION	PGN#	PGN NAME	DEFAULT RATE
Periodic Data PGNs	127505	Fluid Level	0.4 times/second
Response to Requested PGNs	126464	PGN List (Transmit and Receive)	N/A
	126996	Product Information	N/A
	126998	Configuration Information	N/A
Protocol PGNs	059392	ISO Acknowledge	N/A
	059904	ISO Request	N/A
	060928	ISO Address Claim	N/A
	065240	ISO Address Command	N/A
	126208	NMEA Request/Command/Acknowledge	N/A

## ELECTRICAL

PARAMETER	VALUE	COMMENT
Operating Voltage	9 to 16 Volts	DC Voltage
Power Consumption	<100mA	Average Current Drain
Load Equivalence Number (LEN)	2	NMEA 2000® Spec. (1LEN = 50mA)
Reverse Battery Protection	Yes	Indefinitely
Load Dump Protection	Yes	Energy Rated per SAE J1113

## MECHANICAL

PARAMETER	VALUE	COMMENT
Size	3.9" x 1.2" x 1.0" (99mm x 30.5mm x 25.4mm)	Excluding NMEA 2000® Connector & Cable
Weight	9 oz. (255 g)	
Mounting	Any Orientation	

## ENVIRONMENTAL

PARAMETER	VALUE
IEC 60945 Classification	Exposed
Degree of Protection	IP67
Operating Temperature	-25°C to 55°C
Storage Temperature	-40°C to 70°C
Relative Humidity	93%RH @40° per IEC60945-8.2
Vibration	2-13.2Hz @ ±1mm, 13.2-100Hz @ 7m/s² per IEC 60945-8.7
Rain and Spray	12.5mm Nozzle @ 100liters/min from 3m for 30min per IEC 60945-8.8
Solar Radiation	Ultraviolet B, A, Visible, and Infrared per IEC 60945-8.10
Corrosion (Salt Mist)	4 times 7days @ 40°C, 95%RH after 2 hour Salt Spray Per IEC 60945-8.12
Electromagnetic Emission	Conducted and Radiated Emission per IEC 60945-9
Electromagnetic Immunity	Conducted, Radiated, Supply, and ESD per IEC 60945-10
Safety Precautions	Dangerous Voltage, Electromagnetic Radio Frequency per IEC 60945-12

## CERTIFICATIONS

PARAMETER	COMMENT
NMEA 2000® Standard	Level B+
Maritime Navigation and Radio Communication Equipment & Systems	IEC 61162-3
Maritime Navigation and Radio Communication Equipment & Systems	IEC 60945
FCC and CE Mark	Electromagnetic Compatibility



# Engine Monitoring

**Engines are one of the more important systems** on a vessel and the ability to monitor them is essential for assuring safe and trouble free passages. Maretron engine monitoring products communicate critical information like oil pressure and coolant temperature, providing you with early warnings of potential problems before things get out of control. When

coupled with Maretron user interface products, you don't have to stare at the gauges to detect potential problems because programmable alerts or alarms can be set for any parameter. In addition, Maretron state-of-the-art fuel flow monitoring help you find the vessel's optimum running points for substantial fuel savings.



**J2K100**

*J1939 to NMEA 2000® Gateway*



**FFM100**

*Fuel/Fluid Flow Monitor*



**CLM100**

*Current Loop Monitor*







# J2K100

## J1939 to NMEA 2000® Gateway

The J2K100 attaches directly into J1939 networks of compatible engines, transmissions and gensets and converts the J1939 data to the marine digital interface (NMEA 2000®). Critical engine, transmission, and genset data is then distributed throughout the vessel over a single cable where it can be monitored by any NMEA 2000® compatible display.

The J2K100 can also be used as part of a complete fuel computer. Simply connect the J2K100 together with Maretron universal displays (DSM Series, N2KView®) and GPS antenna/receiver (GPS200) and you have a system capable of displaying gallons per hour and/or miles per gallon.

### The J2K100 converts the following information:

- AC Generator Current
- AC Generator Frequency
- AC Generator Voltage
- Tachometer
- Engine Hours
- Coolant Pressure
- Coolant Water Temperature
- Dometic HVAC
- Dometic Icemaker
- Engine Oil Pressure
- Engine Oil Temperature
- Boost Pressure
- Fuel Rate Monitoring
- Charging Voltage
- Percent Engine Load
- Percent Engine Torque
- Rated Engine Speed
- VIN
- Software ID
- Transmission Gear
- Transmission Oil Pressure
- Transmission Oil Temperature



Available accessories for the J2K100:



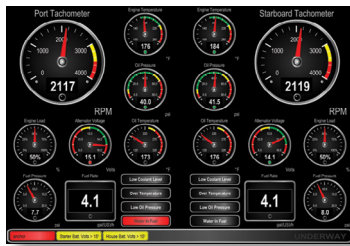
MCF-2M-D4



MCF-2M-D12



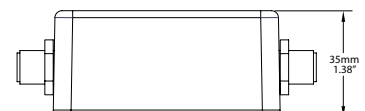
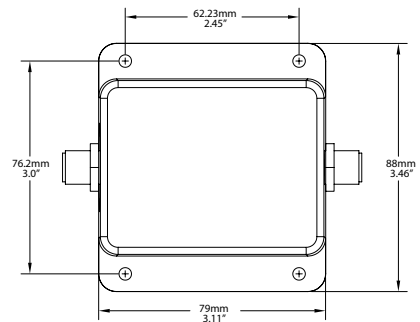
MCF-2M-D12CAT



N2KView® Engine Screen

Engine #0 Speed <b>2243</b> RPM	Total Fuel Rate <b>4.1</b> Gall/Hour
Engine #0 Fuel Rate <b>4.1</b> Gall/Hour	Total Fuel Economy <b>2.6</b> nm/Gallons

DSM Series Screen Shots



### PRODUCTS

PART NUMBER	DESCRIPTION
J2K100-01	J1939 to NMEA 2000® Gateway
MCF-2M-D4	J2K100 adapter Micro female to Deutsch 4 Pin 2 Meter Cordset
MCF-2M-D12	J2K100 adapter Micro female to Deutsch 12 Pin 2 Meter Cordset
MCF-2M-D12CAT	J2K100 adapter Micro female to Deutsch 12 Pin 2 T cable



## SPECIFICATIONS (J1939 Data Translated to NMEA 2000® Data)

J1939 SPN/PGN	DESCRIPTION	NMEA 2000® PGN
190 / 61444	Engine Speed	127488
102 / 65270	Engine Turbocharger Boost Pressure	127488
100 / 65263	Engine Oil Pressure	127489
175 / 65262	Engine Oil Temperature 1	127489
110 / 65262	Engine Coolant Temperature	127489
167 / 65271	Alternator Potential (Voltage)	127489
183 / 65266	Engine Fuel Rate	127489
247 / 65253	Engine Total Hours of Operation	127489
109 / 65263	Engine Coolant Pressure	127489
94 / 65263	Engine Fuel Delivery Pressure	127489
92 / 61443	Engine Percent Load at Current Speed	127489
513 / 61444	Actual Engine – Percent Torque	127489
189 / 65214	Engine Rated Speed	127498
237 / 65260	Vehicle Identification Number	127498
234 / 65242	Software Identification	127498
523 / 61445	Transmission Current Gear	127493
127 / 65272	Transmission Oil Pressure	127493
177 / 65272	Transmission Oil Temperature	127493

## CERTIFICATIONS

PARAMETER	COMMENT
NMEA 2000® Standard	Level B+
Maritime Navigation and Radio Communication Equipment & Systems	IEC 61162-3
Maritime Navigation and Radio Communication Equipment & Systems	IEC 60945
FCC and CE Mark	Electromagnetic Compatibility

## ELECTRICAL

PARAMETER	VALUE	COMMENT
Operating Voltage	9 to 32 Volts	DC Voltage
Power Consumption	< 150mA	Average Current Drain
Load Equivalence Number (LEN)	3	NMEA 2000® Spec. (1LEN = 50mA)
Reverse Battery Protection	Yes	Indefinitely
Load Dump Protection	Yes	Energy Rated per SAE J1113

## NMEA 2000® PARAMETER GROUP NUMBERS (PGNs)

DESCRIPTION	PGN#	PGN NAME	DEFAULT RATE
Periodic Data PGNs	127488	Engine Parameters, Rapid Update	10 times/second
	127489	Engine Parameters, Dynamic	1 time/second
	127498	Engine Parameters, Static	N/A
	127493	Transmission Parameters, Dynamic	10 times/second
	65030	J1939 Generator Average Basic AC Quantities	10 times/second
	65226	J1939 Diagnostic Message #1	N/A
	65227	J1939 Diagnostic Message #2	N/A
	65228	J1939 Diagnostic Message #3	N/A
	65229	J1939 Diagnostic Message #4	N/A
	65230	J1939 Diagnostic Message #5	N/A
	65231	J1939 Diagnostic Message #6	N/A
	65232	J1939 Diagnostic Message #8	N/A
	65234	J1939 Diagnostic Message #10	N/A
Response to Request PGNs	126464	PGN List (Transmit and Receive)	N/A
	126996	Product Information	N/A
	126998	Configuration Information	N/A
	059392	ISO Acknowledge	N/A
Protocol PGNs	059904	ISO Request	N/A
	060928	ISO Address Claim	N/A
	065240	ISO Address Command	N/A
	126208	NMEA Request/Command/Acknowledge	N/A
Maretron Proprietary PGNs	126720	Device Configuration Information	N/A
	130818	Device Label	N/A
	130828	Dometic HVAC Status	N/A
	130830	Dometic Icemaker Status	N/A

## MECHANICAL

PARAMETER	VALUE	COMMENT
Size	3.11" x 3.46" x 1.38" (79mm x 88mm x 35mm)	Including Flanges for Mounting
Weight	8 oz. (227 g)	

## ENVIRONMENTAL

PARAMETER	VALUE
IEC 60945 Classification	Exposed
Degree of Protection	IP67
Operating Temperature	-25°C to 55°C
Storage Temperature	-40°C to 70°C
Relative Humidity	93%RH @40° per IEC60945-8.2
Vibration	2-13.2Hz @ ±1mm, 13.2-100Hz @ 7m/s² per IEC 60945-8.7
Rain and Spray	12.5mm Nozzle @ 100liters/min from 3m for 30min per IEC 60945-8.8
Solar Radiation	Ultraviolet B, A, Visible, and Infrared per IEC 60945-8.10
Corrosion (Salt Mist)	4 times 7days @ 40°C, 95%RH after 2 hour Salt Spray Per IEC 60945-8.12
Electromagnetic Emission	Conducted, Radiated Emission per IEC 60945-9
Electromagnetic Immunity	Conducted, Radiated, Supply, and ESD per IEC 60945-10
Safety Precautions	Dangerous Voltage, Electromagnetic Radio Frequency per IEC 60945-12

**The J2K100 is compatible with any engine, transmission, or genset equipped with a J1939 interface, including products from the following manufacturers:**

- Caterpillar
- Cummins
- Detroit Diesel
- John Deere
- Kohler
- Northern Lights
- Onan
- Perkins
- Steyr
- Volvo Penta
- Yanmar

# FFM100

## Fuel/Fluid Flow Monitoring

The FFM100 provides precision fuel flow information to help optimize fuel consumption, which can save thousands of dollars in fuel operating cost. The FFM100 uses state-of-the-art, positive displacement metering technology for unprecedented accuracy. In fact, the accuracy of the FFM100 is nearly that of commercial vessel systems costing tens of thousands of dollars, yet the FFM100 costs less than existing recreational systems found on the market today. Additional benefits of the positive displacement metering technology are the elimination of flow conditioning components such as straighteners and pulsation dampers. Other flow meter technologies require flow conditioning components that increase system and installation costs. The FFM100 also uses true temperature compensation with embedded temperature sensors within the meters. The returning fuel is generally hotter than the supply fuel and if not properly compensated, inaccuracies as much as 5% can occur in computing the engine's fuel consumption. The FFM100 also detects momentary reverse flow in the fuel lines due to fluctuating pressure caused by the injection pump. Less accurate systems count the reverse fuel flow as part of the consumed fuel where the FFM100 properly accounts for momentary reverse flow. Lastly, the FFM100 can be used for fluid types other than fuel (e.g., water, oil, etc.) by ordering the appropriate flow sender.

### Product Features

- FFM100 converts a variety of flow senders (e.g., fuel, water, etc.) to NMEA 2000® Network Data
- All flow senders ordered separately depending on application (i.e., single fuel flow sender for gas engine, dual fuel flow senders for diesel engine, water flow sender for sea water, etc.)
- Fuel flow senders facilitate fuel consumption optimization for reduced fuel operating cost
- Fuel flow senders use positive displacement metering technology for superior accuracy over other measurement technology such as turbine meters
- Fuel flow senders do not require costly fuel conditioning components like flow straighteners and pulse dampers
- Fuel flow senders implement true temperature compensation with precision built-in thermistors for increased accuracy
- Fuel flow senders automatically detect reverse flow due to fluctuating pressure difference from injection pumps
- Fuel flow senders pass particle sizes up to 70 micrometers (diesel fuel filters normally filter down to 2 micrometers to prevent clogging injectors)

Available accessories for the FFM100:



M1AR



M2AR



M4AR



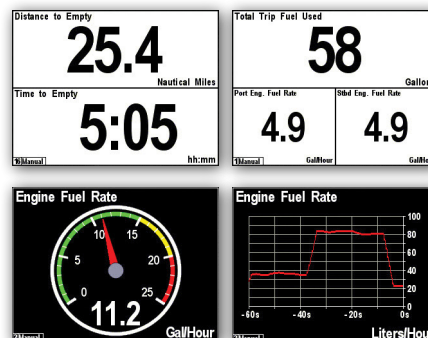
M8AR



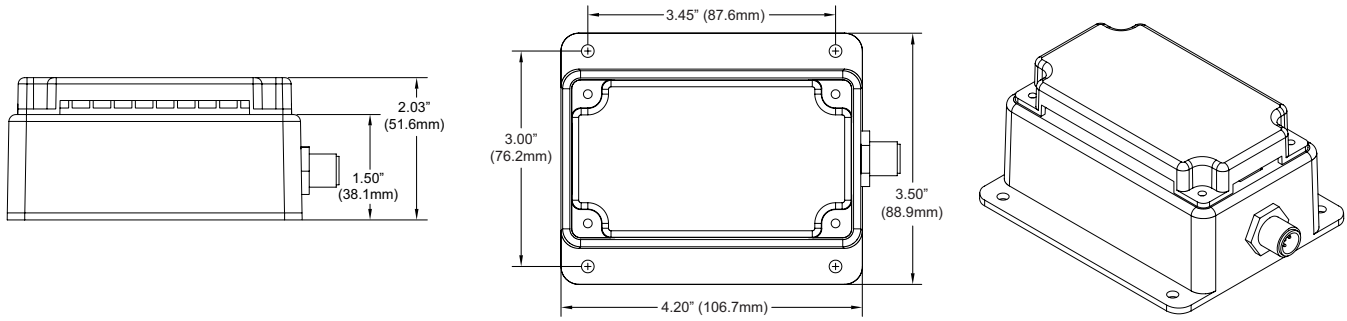
M16AR

### PRODUCTS

PART NUMBER	DESCRIPTION
FFM100-01	Fuel Flow Monitor
M1AR	Fuel Flow Sensor 2-100 LPH (0.53-26.4 GPH)
M2AR	Fuel Flow Sensor 25-500 LPH (6.6-132 GPH)
M4AR	Fuel Flow Sensor 180-1500 LPH (48-396 GPH)
M8AR	Fuel Flow Sensor 8-70 LPM (2.1-18.5 GPM)
M16AR	Fuel Flow Sensor 10-100 LPM (2.6-26.4 GPM)



DSM Series Screen Shots



## SPECIFICATIONS

PARAMETER	VALUE	COMMENT
Accuracy (Differential Mode)	±1.75% of reading	K factors programmed into FFM1000
		4:1 fuel feed / fuel consumption ratio
Accuracy (Two Independent Sensors)	±0.25% of reading	K factors programmed into FFM100
Resolution	0.1 LPH (0.026 GPH)	

## NMEA 2000® PARAMETER GROUP NUMBERS (PGNs)

DESCRIPTION	PGN#	PGN NAME	DEFAULT RATE
Periodic Data PGNs	065286	Fluid Flow Rate (Maretron Proprietary)	2 Times/Second
	065287	Trip Volume (Maretron Proprietary)	2 Times/Second
	127489	Engine Parameters, Dynamic	2 Times/Second
	127497	Trip Parameters, Engine	1 Time/Second
	130312	Temperature	0.5 Times/Second
	130316	Temperature, Extended Range	0.5 Times/Second
Response to Requested PGNs	126464	PGN List (Transmit and Receive)	N/A
	126996	Product Information	N/A
	126998	Configuration Information	N/A
Protocol PGNs	059392	ISO Acknowledge	N/A
	059904	ISO Request	N/A
	060928	ISO Address Claim	N/A
	065240	ISO Address Command	N/A
	126208	NMEA Request/Command/Acknowledge	N/A
Maretron Proprietary PGNs	126720	Device Configuration Information	N/A
	130818	Device Label	N/A

## ELECTRICAL

PARAMETER	VALUE	COMMENT
Operating Voltage	9 to 32 Volts	DC Voltage
Power Consumption	150mA	Maximum Current Drain
Load Equivalence Number (LEN)	3	NMEA 2000® Spec. (1LEN = 50mA)
Reverse Battery Protection	Yes	Indefinitely
Load Dump Protection	Yes	Energy Rated per SAE J1113

## MECHANICAL

PARAMETER	VALUE	COMMENT
Size	3.50" x 4.20" x 2.03" (88.9mm x 106.7mm x 51.6mm)	Including Flanges for Mounting
Weight	13 oz. (368.5 g)	

## ENVIRONMENTAL

PARAMETER	VALUE
IEC 60945 Classification	Exposed
Degree of Protection	IP64
Operating Temperature	-25°C to 55°C
Storage Temperature	-40°C to 70°C
Relative Humidity	93%RH @40° per IEC60945-8.2
Vibration	2-13.2Hz @ ±1mm, 13.2-100Hz @ 7m/s² per IEC 60945-8.7
Solar Radiation	Ultraviolet B, A, Visible, and Infrared per IEC 60945-8.10
Corrosion (Salt Mist)	4 times 7days @ 40°C, 95%RH after 2 hour Salt Spray Per IEC 60945-8.12
Electromagnetic Emission	Conducted, Radiated Emission per IEC 60945-9
Electromagnetic Immunity	Conducted, Radiated, Supply, and ESD per IEC 60945-10
Safety Precautions	Dangerous Voltage, Electromagnetic Radio Frequency per IEC 60945-12

## CERTIFICATIONS

PARAMETER	COMMENT
NMEA 2000® Standard	Level A
Maritime Navigation and Radio Communication Equipment & Systems	IEC 61162-3
Maritime Navigation and Radio Communication Equipment & Systems	Tested to IEC 60945
FCC and CE Mark	Electromagnetic Compatibility



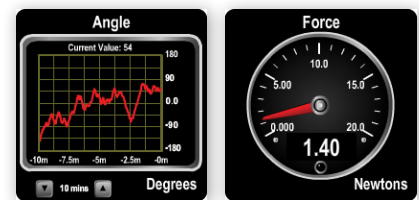
# CLM100

## Current Loop Monitor

The CLM100 converts commercially available 4-20mA current loop transducers into digital data so a wide variety of information can be displayed on Maretron displays. Numerous 4-20mA current loop transducers are supported by the CLM100 including transducers for monitoring DC voltage and current, flow rate, distance, linear velocity and acceleration, angle, angular velocity and acceleration, temperature, humidity, resistance, strain gauges, force (load cell), pressure, decibels, and rotational rate. Some typical applications where the CLM100 is used together with a commercially available 4-20mA transducers include machinery monitoring using accelerometers and vibration sensors. Vibration monitoring of pumps, motors, fans, compressors, and gear boxes provide an early warning of potential problems resulting in fewer breakdowns and reduced maintenance expenses. Another application example using the CLM100 is shaft speed monitoring. A commercially available 4-20mA rotational rate transducer is coupled to the shaft of interest and the CLM100 converts the transducer data to an RPM that can be read on a compatible NMEA 2000® display. And if you're concerned about the force exerted on a mast stay or perhaps a vessel tow attachment point, commercially available clevis pins with a 4-20mA interface can be connected to the CLM100 and the corresponding load monitored using any of Maretron's display products.

### Product Features

- Used together with commercially available 4–20mA current loop transducers
- Converts analog transducer data to digital Data (NMEA 2000®)
- Digital data displayed on Maretron displays



Available accessories for the CLM100:



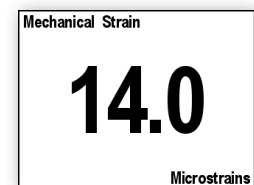
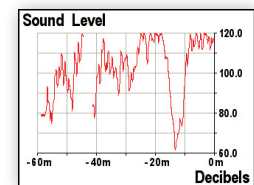
PT-0-xxxxPSI-01



PT-SNUB-01



IRHT-01

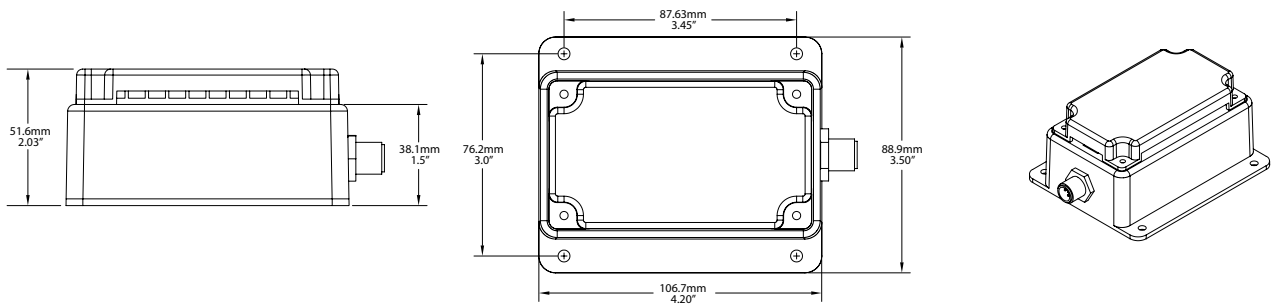


DSM Series Screen Shots

### PRODUCTS

PART NUMBER	DESCRIPTION
CLM100-01	Current Loop Monitor
IRHT-01	Indoor Humidity/Temperature Sensor
PT-0-1.5PSI-01	Pressure Transducer 0 to 1.5 PSI
PT-0-3PSI-01	Pressure Transducer 0 to 3 PSI
PT-0-5PSI-01	Pressure Transducer 0 to 5 PSI
PT-0-10PSI-01	Pressure Transducer 0 to 10 PSI
PT-0-50PSI-01	Pressure Transducer 0 to 50 PSI
PT-0-100PSI-01	Pressure Transducer 0 to 100 PSI

PART NUMBER	DESCRIPTION
PT-0-500PSI-01	Pressure Transducer 0 to 500 PSI
PT-0-1000PSI-01	Pressure Transducer 0 to 1000 PSI
PT-0-5000PSI-01	Pressure Transducer 0 to 5000 PSI
PT-SNUB-01	Pressure Snubber
PT-V-0-1BAR-01	Pressure Transducer Vacuum to 1 Bar
PTS-0-1.5PSI-01	Submersible Pressure Transducer 0 to 1.5 PSI
PTS-0-3PSI-01	Submersible Pressure Transducer 0 to 3 PSI
PTS-0-5PSI-01	Submersible Pressure Transducer 0 to 5 PSI



## SPECIFICATIONS

PARAMETER	VALUE	COMMENT
Number of Channels	6	Independently Programmable
Operating Modes	DC Voltage, DC Current, Flow Rate, Distance, Linear Velocity, Linear Acceleration, Angle, Angular Velocity, Angular Acceleration, Temperature, Humidity, Resistance, Strain Gauge, Force (Load Cell), Pressure, Decibels, Rotational Rate	
Transducer Interface	4-20mA current loop	
Current Loop Excitation Voltage	12-15 VDC	
Accuracy	+/-1% FS	Exclusive of Transducer
Resolution	+/-0.33% FS	Over Full Transducer Range

## NMEA 2000® PARAMETER GROUP NUMBERS (PGNs)

DESCRIPTION	PGN#	PGN NAME	DEFAULT RATE
Periodic Data PGNs	065286	Fluid Flow Rate (Maretron Proprietary)	2 Times/Second
	127488	Engine Parameters, Rapid Update	10 Times/Second
	127489	Engine Parameters, Dynamic	1 Time/Second
	127493	Transmission Parameters, Dynamic	10 Times/Second
	127508	Battery Status	0.67 Times/Second
	127751	DC Voltage/Current	0.67 Times/Second
	130313	Humidity	0.5 Times/Second
	130314	Actual Pressure	0.5 Times/Second
	130316	Temperature, Extended Range	0.5 Times/Second
	130576	Trim Tab Status	5 Times/Second
Response to Requested PGNs	130840	Generic Sensor (Maretron Proprietary)	1 Time/Second
	126464	PGN List (Transmit and Receive)	N/A
	126996	Product Information	N/A
Protocol PGNs	126998	Configuration Information	N/A
	059392	ISO Acknowledge	N/A
	059904	ISO Request	N/A
	060928	ISO Address Claim	N/A
	065240	ISO Address Command	N/A
Maretron Proprietary PGNs	126208	NMEA Request/Command/Acknowledge	N/A
	126720	Device Configuration Information	N/A
	130818	Device Label	N/A

## ELECTRICAL

PARAMETER	VALUE	COMMENT
Operating Voltage	9 to 32 Volts	DC Voltage
Power Consumption	400mA	Maximum Current Drain
Load Equivalence Number (LEN)	8	NMEA 2000® Spec. (1LEN = 50mA)
Reverse Battery Protection	Yes	Indefinitely
Load Dump Protection	Yes	Energy Rated per SAE J1113

## MECHANICAL

PARAMETER	VALUE	COMMENT
Size	3.50" x 4.20" x 2.03" (88.9mm x 106.7mm x 51.6mm)	Including Flanges for Mounting
Weight	13 oz. (368.5 g)	

## ENVIRONMENTAL

PARAMETER	VALUE
IEC 60945 Classification	Exposed
Degree of Protection	IP64
Operating Temperature	-25°C to 55°C
Storage Temperature	-40°C to 70°C
Relative Humidity	93%RH @40° per IEC60945-8.2
Vibration	2-13.2Hz @ ±1mm, 13.2-100Hz @ 7m/s <sup>2</sup> per IEC 60945-8.7
Solar Radiation	Ultraviolet B, A, Visible, and Infrared per IEC 60945-8.10
Corrosion (Salt Mist)	4 times 7days @ 40°C, 95%RH after 2 hour Salt Spray Per IEC 60945-8.12
Electromagnetic Emission	Conducted, Radiated Emission per IEC 60945-9
Electromagnetic Immunity	Conducted, Radiated, Supply, and ESD per IEC 60945-10
Safety Precautions	Dangerous Voltage, Electromagnetic Radio Frequency per IEC 60945-12

## CERTIFICATIONS

PARAMETER	COMMENT
NMEA 2000® Standard	Level A
Maritime Navigation and Radio Communication Equipment & Systems	IEC 61162-3
Maritime Navigation and Radio Communication Equipment & Systems	Tested to IEC 60945
FCC and CE Mark	Electromagnetic Compatibility

# Electrical Monitoring and Control

**The Maretron brand offers** the widest variety of NMEA 2000® electrical monitoring and control products in the industry. We have products for monitoring your AC electrical systems (shore power, generators, or inverters), as well as products for monitoring your DC systems (batteries, solar panels, or wind power). In addition to electrical monitoring products, Maretron offers solid state relays for controlling DC loads (DCR100). The DCR100 not only allows you to control up to six DC loads from any NMEA 2000 compatible display, you can monitor the current flowing to the load and be alerted if a bulb or

pump is inadvertently burned out. Maretron's Run Indicator Module (RIM100) lets you know when electrical devices are energized and operating. The RIM100 includes counters and timers so you can keep track of electrical circuit activity. Imagine knowing exactly the frequency and duration that the bilge has run.

The newly introduced DC Load Modules, Switches and Keypads extend the range with powerful options to control lights and inductive loads.



**ACM100**  
*Alternating Current Monitor*



**DCM100**  
*Direct Current Monitor*



**DCR100**  
*Direct Current Relay*



**RIM100**  
*Run Indicator Module*







# ACM100

## Alternating Current Monitor

The ACM100 is a device that monitors AC power sources and outputs information about these sources onto the industry standard NMEA 2000® marine data network. ACM100 output information is then displayed with networked NMEA 2000 equipment such as the Maretron DSM Series dedicated displays or with NMEA 2000 compatible software such as Maretron N2KView®.

### Product Features

- NMEA 2000® Interface
- Waterproof connectors
- Sealed waterproof enclosure
- Single phase, split phase or 3-phase AC Sources
- Opto-isolated from NMEA 2000 eliminating potential ground loops
- Monitoring of busses carrying AC power and transmitting:
  - Voltage
  - Frequency
- Monitoring AC Power sources such as utilities and generators and transmitting:
  - Voltage
  - Current
  - Frequency
  - Real Power
  - Reactive Power
  - Apparent Power
  - Power Factor
  - Total Energy Imported
  - Total Energy Exported



Available accessories for the ACM100:



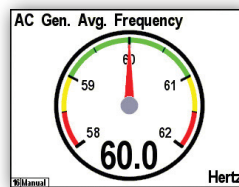
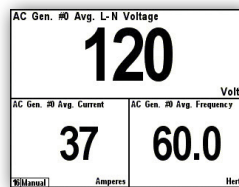
M000630



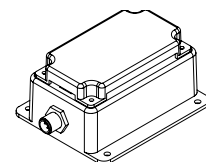
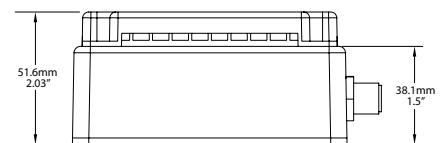
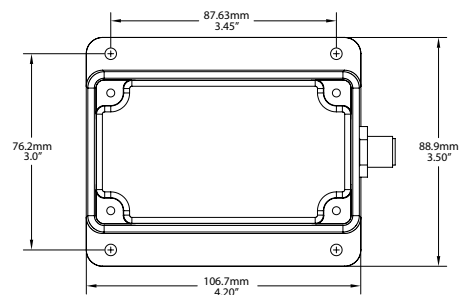
M000612



N2KView® Screen



DSM Series Screen Shots



### PRODUCTS

PART NUMBER	DESCRIPTION
ACM100-01	Alternating Current (AC) Monitor w/ 100 Amp AC Transducer
M000630	100 Amp AC Transducer with Cable
M000612	400 Amp AC Transducer with Cable

## SPECIFICATIONS

PARAMETER	VALUE	COMMENT
Measurement Capabilities		Single Phase 120, 208, 230, 240
		Split Phase 120/240
		3-Phase Delta 208, 230, 400, 480, 600
		3-Phase Wye 208Y/120, 400Y/230, 415Y/240, 480Y/277, 600Y/347
		Delta with Wild Phase 120/208/240
Measurement Voltage Range	0-380 VAC	Line-to-Neutral
Measurement Voltage Accuracy	±1%	
Measurement Current Range	0-100 A	With included current transducer (0 to 400A with optional transducer)
Measurement Current Accuracy	±1%	With included current transducer
Measurement Frequency Range	30-80Hz	
Measurement Frequency Accuracy	0.5Hz	Typical

## NMEA 2000® PARAMETER GROUP NUMBERS (PGNs)

DESCRIPTION	PGN#	PGN NAME	DEFAULT RATE
Periodic Data PGNs	65001-65003	Bus Phase A-C Basic AC Quantities	Disabled
	65004	Bus Average Basic AC Quantities	2 times/second
	65005	Utility Total AC Energy	2 times/second
	65006-65014	Utility Phase A-C Power and Basic Quantities	Disabled
	65015	Utility Total AC Reactive Power	2 times/second
	65016	Utility Total AC Power	2 times/second
	65017	Utility Average Basic AC Quantities	2 times/second
	65018	Generator Total AC Energy	2 times/second
	65019-65027	Generator Phase A-C Power and Basic Quantities	Disabled
	65028	Generator Total AC Reactive Power	2 times/second
	65029	Generator Total AC Power	2 times/second
65030	Generator Average Basic AC Quantities	2 times/second	
Response to Requested PGNs	126464	PGN List (Transmit and Receive)	N/A
	126996	Product Information	N/A
	126998	Configuration Information	N/A
Protocol PGNs	059392	ISO Acknowledge	N/A
	059904	ISO Request	N/A
	060928	ISO Address Claim	N/A
	065240	ISO Address Command	N/A
	126208	NMEA Request/Command/Acknowledge	N/A
Maretron Proprietary PGNs	126720	Device Configuration Information	N/A
	130818	Device Label	N/A

## ELECTRICAL

PARAMETER	VALUE	COMMENT
Operating Voltage	9 to 32 Volts	DC Voltage
Power Consumption	50mA	NMEA 2000® Interface
Load Equivalence Number (LEN)	1	NMEA 2000® Spec. (1LEN = 50mA)
Reverse Battery Protection	Yes	Indefinitely
Load Dump Protection	Yes	Energy Rated per SAE J1113

## MECHANICAL

PARAMETER	VALUE	COMMENT
Size	3.50" x 4.20" x 2.03" (88.9mm x 106.7mm x 51.6mm)	Excluding NMEA 2000® Connector & Cable
Weight	13 oz. (368.5 g)	

## ENVIRONMENTAL

PARAMETER	VALUE
IEC 60945 Classification	Exposed
Degree of Protection	IP64
Operating Temperature	-25°C to 55°C
Storage Temperature	-40°C to 70°C
Relative Humidity	93%RH @40° per IEC60945-8.2
Vibration	2-13.2Hz @ ±1mm, 13.2-100Hz @ 7m/s² per IEC 60945-8.7
Rain and Spray	12.5mm Nozzle @ 100liters/min from 3m for 30min per IEC 60945-8.8
Solar Radiation	Ultraviolet B, A, Visible, and Infrared per IEC 60945-8.10
Corrosion (Salt Mist)	4 times 7days @ 40°C, 95%RH after 2 hour Salt Spray Per IEC 60945-8.12
Electromagnetic Emission	Conducted and Radiated Emission per IEC 60945-9
Electromagnetic Immunity	Conducted, Radiated, Supply, and ESD per IEC 60945-10
Safety Precautions	Dangerous Voltage, Electromagnetic Radio Frequency per IEC 60945-12

## CERTIFICATIONS

PARAMETER	COMMENT
NMEA 2000® Standard	Level A
Maritime Navigation and Radio Communication Equipment & Systems	IEC 61162-3
Maritime Navigation and Radio Communication Equipment & Systems	IEC 60945
FCC and CE Mark	Electromagnetic Compatibility



# DCM100

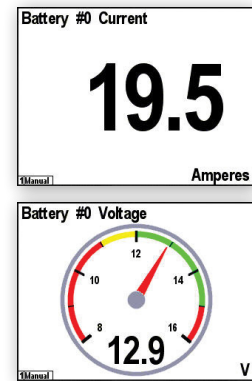
## Direct Current Monitor

The DCM100 DC Monitor is an advanced electronic monitoring device used to measure the voltage and current of any direct current (DC) power source or load. Examples of DC power sources that can be monitored with the DCM100 include batteries, alternators, solar panels, and wind generators. The DCM100 can also be used to monitor DC loads like inverters, windlasses, DC refrigerators, or any DC branch circuit. When the DCM100 is used to monitor batteries, sophisticated circuitry and software algorithms monitor battery temperature, load current, charging current and terminal voltage to precisely compute battery state of charge, and time remaining. To measure current, the DCM100 uses an included state-of-the-art Hall effect current sensor which simply slips over the wire—you don't have to break connections or install connectors as you do with inline shunts used in other solutions. Best of all, the DCM100 is NMEA 2000® certified so you can view any and all DC information anywhere on the vessel using a compatible NMEA 2000 display. The DCM100 is a key component of Maretron's N2KView® vessel monitoring and control system.



### Information monitored:

- Battery Voltage
- Battery Current
- Ripple Voltage
- Battery Case Temperature
- State of Charge
- Time Remaining
- Charge Efficiency Factor



DSM Series Screen Shots

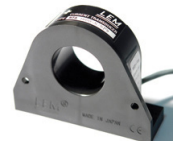


TSM Series Screen Shot

Available accessory is for the DCM100:



FC01



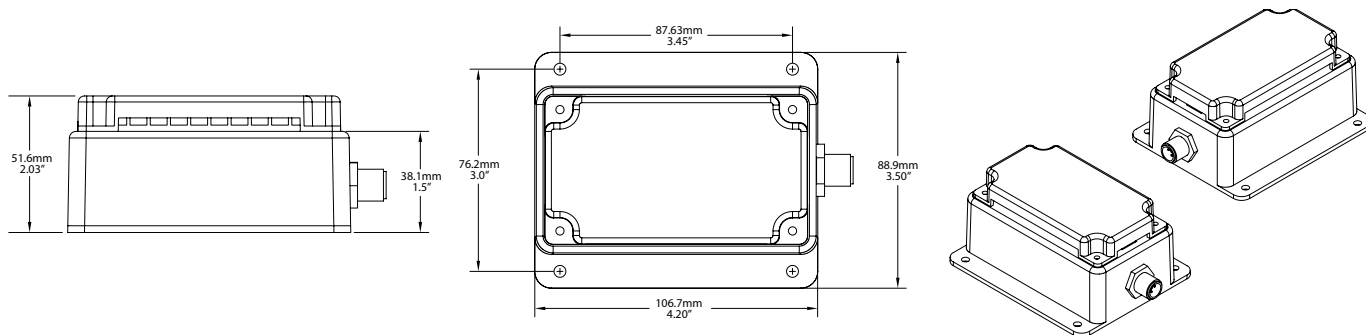
LEMHTAx00-S



TR3K

### PRODUCTS

PART NUMBER	DESCRIPTION
DCM100-01	Direct Current (DC) Monitor w/ 200 Amp Current Transducer (includes FC01, LEMHTA200-S and TR3K)
FC01	DCM100 Battery Harness with Fuse
LEMHTA200-S	200 Amp Current Transducer with Cable
LEMHTA400-S	400 Amp Current Transducer with Cable
LEMHTA600-S	600 Amp Current Transducer with Cable
TR3K	DCM100 Ring/Under Bolt Temperature Probe



## SPECIFICATIONS

PARAMETER	VALUE	COMMENT
Battery Sense Voltage Range	0 to 50 VDC	
Battery Sense Voltage Accuracy	±100 mV	
Battery Current Range	0 to 200A	With included Hall-effect current sensor
Battery Current Accuracy	±1 %	With included Hall-effect current sensor

## NMEA 2000® PARAMETER GROUP NUMBERS (PGNs)

DESCRIPTION	PGN#	PGN NAME	DEFAULT RATE
Periodic Data PGNs	127506	DC Detailed Status	0.67 times/second
	127508	Battery Status	0.67 times/second
	127513	Battery Configuration Status	N/A
Response to Requested PGNs	126464	PGN List (Transmit and Receive)	N/A
	126996	Product Information	N/A
	126998	Configuration Information	N/A
Protocol PGNs	059392	ISO Acknowledge	N/A
	059904	ISO Request	N/A
	060928	ISO Address Claim	N/A
	065240	ISO Address Command	N/A
	126208	NMEA Request/Command/Acknowledge	N/A
Maretron Proprietary PGNs	126720	Device Configuration Information	N/A
	130818	Device Label	N/A

## ELECTRICAL

PARAMETER	VALUE	COMMENT
Operating Voltage	9 to 32 Volts	NMEA Interface
	9 to 32 Volts	Battery Interface
Power Consumption (Battery Interface)	70mA	
Power Consumption (NMEA 2000® Connection)	50mA	
Load Equivalence Number (LEN)	1	NMEA 2000® Spec. (1LEN = 50mA)
Reverse Battery Protection	Yes	Indefinitely
Load Dump Protection	Yes	Energy Rated per SAE J1113

## MECHANICAL

PARAMETER	VALUE	COMMENT
Size	3.50" x 4.20" x 2.03" (88.9mm x 106.7mm x 51.6mm)	Including Flanges for Mounting
Weight	13 oz. (368.5 g)	

## ENVIRONMENTAL

PARAMETER	VALUE
IEC 60945 Classification	Exposed
Degree of Protection	IP64
Operating Temperature	-25°C to 55°C
Storage Temperature	-40°C to 70°C
Relative Humidity	93%RH @40° per IEC60945-8.2
Vibration	2-13.2Hz @ ±1mm, 13.2-100Hz @ 7m/s² per IEC 60945-8.7
Solar Radiation	Ultraviolet B, A, Visible, and Infrared per IEC 60945-8.10
Corrosion (Salt Mist)	4 times 7days @ 40°C, 95%RH after 2 hour Salt Spray Per IEC 60945-8.12
Electromagnetic Emission	Conducted, Radiated Emission per IEC 60945-9
Electromagnetic Immunity	Conducted, Radiated, Supply, and ESD per IEC 60945-10
Safety Precautions	Dangerous Voltage, Electromagnetic Radio Frequency per IEC 60945-12

## CERTIFICATIONS

PARAMETER	COMMENT
NMEA 2000® Standard	Level A
Maritime Navigation and Radio Communication Equipment & Systems	IEC 61162-3
Maritime Navigation and Radio Communication Equipment & Systems	Tested to IEC 60945
FCC and CE Mark	Electromagnetic Compatibility

# DCR100

## Direct Current Relay Module

The DCR100 contains 6 Direct Current (DC) relays, each capable of switching up to 10 amps. The DCR100 connects directly to an NMEA 2000® network, so you can turn on and off the relays from any device onboard or remotely running Maretron's N2KView® software. The DCR100 easily handles resistive DC loads like lights, or inductive DC loads like pumps and motors. The DCR100 can also be used to switch AC circuits using external relays. An added benefit of the DCR100 is that it reports the current through each of the six channels. This allows you to determine if loads are drawing too little electrical current such as burnt-out bulbs, or if the loads are starting to draw too much electrical current.



### Product Features

- Six relays for On/Off control over NMEA 2000® Network
- Each relay capable of carrying up to 10 amps
- Individual relay electrical current monitoring
- Automatic relay over current shutdown (shuts down at  $\approx$  12 amps)
- Automatic relay thermal shutdown (over temperature protection)
- Relays switchable using Maretron DSM Series, N2KView®, or N2KView® Mobile
- DCR100 can be configured as an annunciator to activate a buzzer, horn, or strobe light as a result of an alert
- Individual DCR100 channels can be locked into On/Off state
- Individual DCR100 channels can be configured with default power up state (e.g., On/Off/Previous)

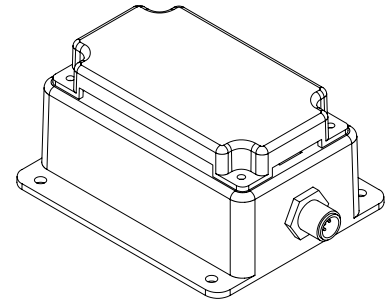
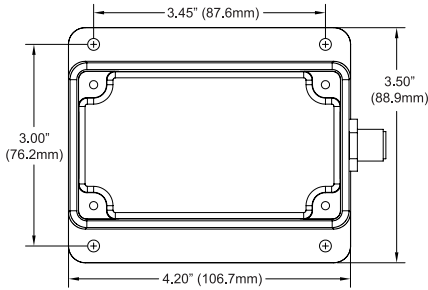
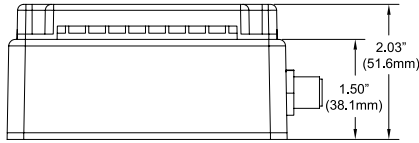


N2KView® Screen Shot

### PRODUCT

PART NUMBER	DESCRIPTION
DCR100-01	Direct Current Relays





## SPECIFICATIONS

PARAMETER	VALUE	COMMENT
Maximum DC Switching Current	10A	Maximum Current Per Channel
DC Switching Voltage	<32 VDC	
Contact Resistance	<10 mΩ	
Current Sense Accuracy	±100mA	

## NMEA 2000® PARAMETER GROUP NUMBERS (PGNs)

DESCRIPTION	PGN#	PGN NAME	DEFAULT RATE
Periodic Data PGNs	65284	DC Breaker Current (Maretron Proprietary)	1 time per second
	127501	Binary Switch Bank Status	1 Time/15 seconds and on switch change
	130836	Switch Status Counter (Maretron Proprietary)	1 Time/15 seconds and on switch change
	130837	Switch Status Timer (Maretron Proprietary)	1 Time/15 seconds and on switch change
Response to Requested PGNs	126464	PGN List (Transmit and Receive)	N/A
	126996	Product Information	N/A
	126998	Configuration Information	N/A
Protocol PGNs	059392	ISO Acknowledge	N/A
	059904	ISO Request	N/A
	060928	ISO Address Claim	N/A
	065240	ISO Address Command	N/A
	126208	NMEA Request/Command/Acknowledge	N/A
Maretron Proprietary PGNs	126720	Device Configuration Information	N/A
	130818	Device Label	N/A
	130824	Annunciator	1 time/second

## ELECTRICAL

PARAMETER	VALUE	COMMENT
Operating Voltage	9 to 32 Volts	DC Voltage
Power Consumption	150mA	NMEA 2000® Interface
Load Equivalence Number (LEN)	3	NMEA 2000® Spec. (1LEN = 50mA)
Reverse Battery Protection	Yes	Indefinitely
Load Dump Protection	Yes	Energy Rated per SAE J1113

## MECHANICAL

PARAMETER	VALUE	COMMENT
Size	3.50" x 4.20" x 2.03" (88.9mm x 106.7mm x 51.6mm)	Including Flanges for Mounting
Weight	13 oz. (368.5 g)	

## ENVIRONMENTAL

PARAMETER	VALUE
IEC 60945 Classification	Exposed
Degree of Protection	IP64
Operating Temperature	-25°C to 55°C
Storage Temperature	-40°C to 70°C
Relative Humidity	93%RH @40° per IEC60945-8.2
Vibration	2-13.2Hz @ ±1mm, 13.2-100Hz @ 7m/s² per IEC 60945-8.7
Solar Radiation	Ultraviolet B, A, Visible, and Infrared per IEC 60945-8.10
Corrosion (Salt Mist)	4 times 7days @ 40°C, 95%RH after 2 hour Salt Spray Per IEC 60945-8.12
Electromagnetic Emission	Conducted, Radiated Emission per IEC 60945-9
Electromagnetic Immunity	Conducted, Radiated, Supply, and ESD per IEC 60945-10
Safety Precautions	Dangerous Voltage, Electromagnetic Radio Frequency per IEC 60945-12

## CERTIFICATIONS

PARAMETER	COMMENT
NMEA 2000®	Level A
Maritime Navigation and Radio Communication Equipment & Systems	IEC 61162-3
Maritime Navigation and Radio Communication Equipment & Systems	Tested to IEC 60945
FCC and CE Mark	Electromagnetic Compatibility

# RIM100

## Run Indicator Module

The Run Indicator Module monitors both AC and DC electrical circuits and reports, over an NMEA 2000® network, whether or not the electrical circuit is energized and running. The RIM100 works equally as well for monitoring manually switched loads (e.g., running lights, anchor lights, or deck lights) as it does for automatically switched loads. Monitoring automatically switched loads (e.g., bilge pumps, engine exhaust/intake fans, and transfer pumps) via the RIM100 is especially useful because you know exactly when equipment is, or isn't, running.



### Product Features

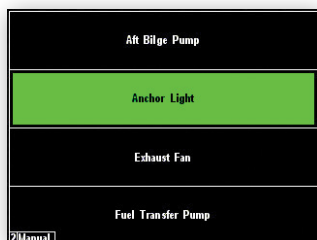
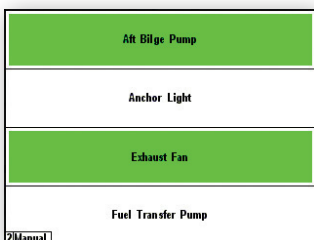
- Monitors and reports the running statuses of six independently connected devices
- Works with both AC and DC loads
- Works with both automatically and manually switched loads
- Can indicate the status of a wide variety of loads
  - Bilge Pumps
  - Winches
  - Running Lights
  - Transfer Pumps
  - Exhaust/Intake Fans
  - Water in Fuel notification
- Includes built-in timers and counters so you know how long and many times a load is energized

Available accessories for the RIM100:



### WIF-RK30880-E Water in Fuel Detector

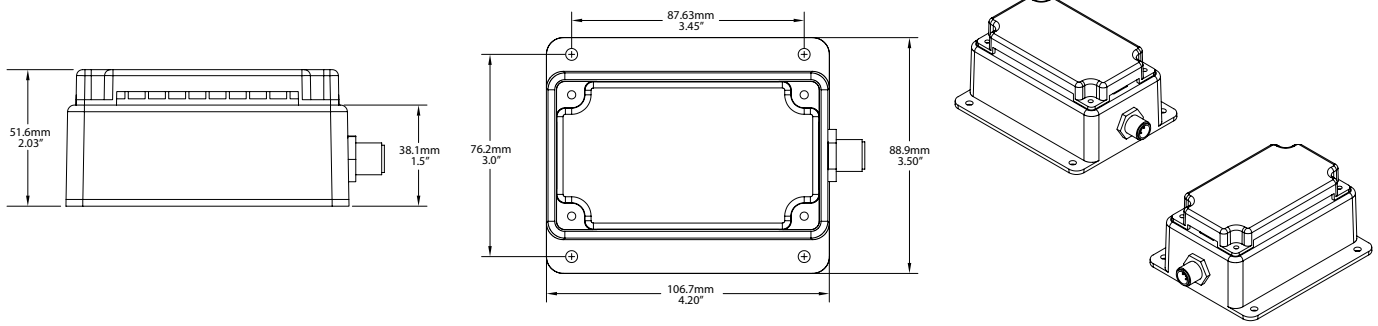
A WIF-RK30880-E Fuel detector mounted on the bottom of a fuel filter will provide a voltage when water is detected in the fuel. This voltage can be detected by the RIM100 and used to trigger an Alert or display an Indicator.



DSM Series Screen Shots

### PRODUCTS

PART NUMBER	DESCRIPTION
RIM100-01	Run Indicator Module
WIF-RK30880-E	Water in Fuel Detector



## SPECIFICATIONS

PARAMETER	VALUE	COMMENT
Number of Channels	6	
"OFF" Voltage Range (DC)	0VDC-1VDC	
"OFF" Voltage Range (AC)	0VAC-1VAC	RMS
"ON" Voltage Range (DC)	9VDC to 240VDC	
"ON" Voltage Range (AC)	9VAC to 240VAC	RMS

## NMEA 2000® PARAMETER GROUP NUMBERS (PGNs)

DESCRIPTION	PGN#	PGN NAME	DEFAULT RATE
Periodic Data PGNs	127501	Binary Switch Bank Status	1 Time/15 seconds and on switch change
	130836	Switch Status Counter	1 Time/15 seconds and on switch change
	130837	Switch Status Timer	1 Time/15 seconds and on switch change
Response to Requested PGNs	126464	PGN List (Transmit and Receive)	N/A
	126996	Product Information	N/A
	126998	Configuration Information	N/A
Protocol PGNs	059392	ISO Acknowledge	N/A
	059904	ISO Request	N/A
	060928	ISO Address Claim	N/A
	065240	ISO Address Command	N/A
	126208	NMEA Request/Command/Acknowledge	N/A
Maretron Proprietary PGNs	126720	Device Configuration Information	N/A
	130818	Device Label	N/A

## ELECTRICAL

PARAMETER	VALUE	COMMENT
Operating Voltage	9 to 32 Volts	DC Voltage
Power Consumption	50mA	NMEA 2000® Interface
Load Equivalence Number (LEN)	1	NMEA 2000® Spec. (1LEN = 50mA)
Reverse Battery Protection	Yes	Indefinitely
Load Dump Protection	Yes	Energy Rated per SAE J1113

## MECHANICAL

PARAMETER	VALUE	COMMENT
Size	3.50" x 4.20" x 2.03" (88.9mm x 106.7mm x 51.6mm)	Including Flanges for Mounting
Weight	13 oz. (368.5 g)	

## ENVIRONMENTAL

PARAMETER	VALUE
IEC 60945 Classification	Exposed
Degree of Protection	IP64
Operating Temperature	-25°C to 55°C
Storage Temperature	-40°C to 70°C
Relative Humidity	93%RH @40° per IEC60945-8.2
Vibration	2-13.2Hz @ ±1mm, 13.2-100Hz @ 7m/s² per IEC 60945-8.7
Solar Radiation	Ultraviolet B, A, Visible, and Infrared per IEC 60945-8.10
Corrosion (Salt Mist)	4 times 7days @ 40°C, 95%RH after 2 hour Salt Spray Per IEC 60945-8.12
Electromagnetic Emission	Conducted, Radiated Emission per IEC 60945-9
Electromagnetic Immunity	Conducted, Radiated, Supply, and ESD per IEC 60945-10
Safety Precautions	Dangerous Voltage, Electromagnetic Radio Frequency per IEC 60945-12

## CERTIFICATIONS

PARAMETER	COMMENT
NMEA 2000®	Level A
Maritime Navigation and Radio Communication Equipment & Systems	IEC 61162-3
Maritime Navigation and Radio Communication Equipment & Systems	Tested to IEC 60945
FCC and CE Mark	Electromagnetic Compatibility



# Digital Switching Platform

**MPOWER® IS A FLEXIBLE AND SCALABLE** platform designed to control DC systems using configurable keypads, switch modules and multifunction displays. Designed for small runabout vessels to large yachts and beyond, MPower simplifies installation and delivers easy, intuitive control over the increasingly complex systems found on today's vessels.

All MPower products connect directly to the NMEA 2000® network providing access to and compatibility with an array of sensors and instrumentation. If you are a boatbuilder, technical dealer, or a savvy DIY boat owner already familiar with Maretron's vast monitoring & control ecosystem, MPower delivers impressive, distributed

power and digital switching capabilities. Because of MPower's use of standard PGNs (versus proprietary messages), MPower easily integrates with an NMEA 2000 system or MFD you likely already service or own.

As part of the Carling Technologies family, with over 100 years of expertise in switches and circuit protection, Maretron customers have the added bonus of a global network of sales and support. We are your ONE source for creating the intelligent boat ... from cables & connectors to complete vessel monitoring & control solutions.

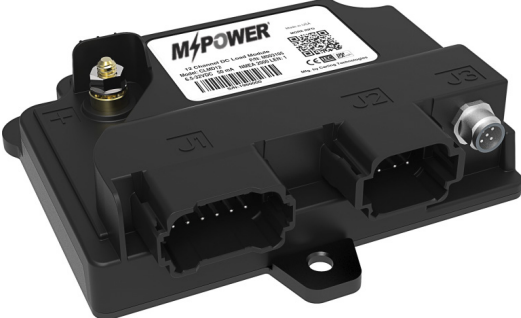
Marine has been our passion for decades. It's where we live, work and play—today, tomorrow and in the future.



NMEA 2000® Certified products are listed on the NMEA website [www.NMEA.org](http://www.NMEA.org).

# MPOWER<sup>®</sup>

Digital Switching Platform



### CLMD12

*12-Channel DC Load Controller Module*



### CBMD12

*12-Channel Bypass Module*



### CLMD16

*16-Channel DC Load Controller Module*



### VMM6

*Contura<sup>®</sup> Digital Switch Module, 6 Rocker*



### CKM12

*12-Button Customizable Keypad*



### WSV100

*MConnect HTML5 Web Server*

# 12-Channel DC Load Controller Module



Designed for vessels of all sizes with smaller loads, the MPower® CLMD12 is a compact 12-Channel DC Load Controller Module. Two of the 12 breakers handle a maximum of 12 amps, six handle a maximum of 10 amps and four handle a maximum of 5 amps with a total current capacity of 75 amps. Additionally, like circuits can be paralleled.

If a smaller circuit needs to be protected, each of the 12 breakers can be set to trip at lower current levels using the new Maretron N2KAnalyzer® V3 software. In addition, the CLMD12 has inputs for up to 7 hard-wired switches that can be used to switch breaker states, or as inputs for other data such as bilge alarms or hatch positions, etc.

The CLMD12 handles many DC load types such as lights, pumps, motors, and electronics. An added benefit of the CLMD12 is that it reports the current through each of the 12 breakers. This allows you to determine if loads are drawing too much or too little electrical current. This information can be used to report overcurrent faults and undercurrent conditions.

For manual control of the loads, an MPower 12-Channel Bypass Module (CBMD12) can be installed in conjunction with the CLMD12.

Monitor and control onboard electrical and electronic systems and reset circuits onboard and remotely with the following devices:

- Any 3rd party MFD that supports standard digital switching PGNs
- Maretron MBB300C Black Box
  - Garmin OneHelm™
  - Raymarine LightHouse 4
- Maretron TSM Series Dedicated Touchscreen
- MPower VMM6 Digital Switch Module
- MPower CKM12 Keypad
- Any device running Maretron's award-winning N2KView® V3 Software



## Product Features

- NMEA 2000® Interface
- IP67 Rated
- Ignition Protected
- Opto-isolated from NMEA 2000, eliminating potential ground loops
- 12 dimmable (PWM) Electronic Circuit Breakers (ECBs) for ON/OFF control over NMEA 2000 network
  - 2 breakers capable of carrying up to 12 amps
  - 6 breakers capable of carrying up to 10 amps
  - 4 breakers capable of carrying up to 5 amps
- Individual breaker electrical current monitoring
- Breakers can have power-up states defined (ON, OFF, or LAST STATE)
- Breakers can be locked against inadvertent actuation
- 7 discrete inputs configurable as Active High, Active Low
- Automatic ECB overcurrent shutdown
- Automatic ECB thermal shutdown (overtemperature protection)

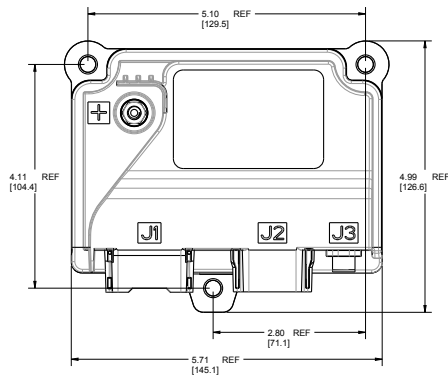
## PRODUCTS

PART NUMBER	DESCRIPTION
CLMD12-R	12-Channel DC Load Controller Module w/A3706 and A3707
CLMD12	12-Channel DC Load Controller Module
A3706	Output (J1) Mating Connector with 0.3m Flying Leads
A3707	Input (J2) Mating Connector with 0.3m Flying Leads

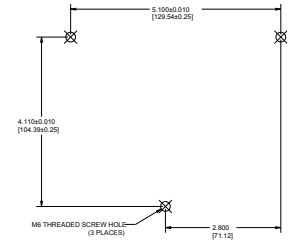
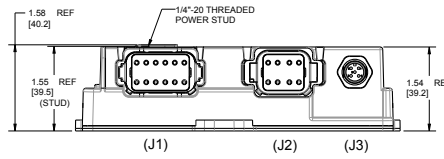
PART NUMBER	DESCRIPTION
DT06-12SA	J1 (Output) Mating Connector, Deutsch
0462-209-16141	J1 (Output) 14AWG Socket, Deutsch
W12S	J1 (Output) Wedge, Deutsch
1028-043-1205	J1 Back Shell, 12 Way Plug, Deutsch
DT06-08SA-E003	J2 (Input) Mating Connector, Deutsch
0462-201-16141	J2 (Input) 16-20AWG Socket, Deutsch
W8S	J2 (Input) Wedge, Deutsch
1011-243-0805	J2 Back Shell, 8 Way Plug, Deutsch



## Dimensional Specifications - Inch [mm]



- NOTES:
1. WEIGHT: 1.25 LBS. (0.567 KG.) MAX.
  2. TEMPERATURE: OPERATING -40° C TO 85° C.  
STORAGE -55° C TO 85° C.
  3. MATING CONNECTIONS:  
J1 - DEUTSCH PIN DT06-12SA  
J2 - DEUTSCH PIN DT06-08SA-E003  
J3 - MICRO-C MALE CONNECTOR, M12 X 1



## SPECIFICATIONS

PARAMETER	VALUE
Number of Channels	12
Switching Voltage	< 32 VDC
Maximum Unit Current Capacity	75 amps
Maximum Channel Current Ratings	4x5A, 6x10A, 2x12A

## CERTIFICATIONS

PARAMETER	COMMENT
NMEA 2000	Certified
CE Mark	Recreational Craft Directive 2014/35/EU

## NMEA 2000® PARAMETER GROUP NUMBERS (PGNs)

DESCRIPTION	PGN#	PGN NAME	DEFAULT RATE
Periodic Data PGNs	65300	Carling Proprietary	1 time / 4 seconds
	127500	Load Controller Connection State & Control	1 time / 4 seconds and on switch change
	127501	Binary Switch Bank Status	1 time / 15 seconds and on switch change
	127751	DC Voltage / Current	1 time / 15 seconds
Response to Requested PGNs	126464	PGN List (Transmit and Receive)	N/A
	126996	Product Information	N/A
	126998	Configuration Information	N/A
	130818	Maretron Proprietary	N/A
	130825	Maretron Proprietary	N/A
	130921	Carling Proprietary	N/A
Protocol PGNs	059392	ISO Acknowledge	N/A
	059904	ISO Request	N/A
	060928	ISO Address Claim	N/A
	126208	NMEA Request/Command/Acknowledge	N/A
	126993	Heartbeat	1 time / 60 seconds
	130060	Label	N/A

## ELECTRICAL

PARAMETER	VALUE	COMMENT
Voltage Input Range	6.5 to 32 VDC	DC Voltage
Power Consumption	150mA @ 12 VDC / 70 mA @ 24 VDC	NMEA 2000 Interface
Load Equivalence Number (LEN)	3	NMEA 2000 Spec. (1LEN = 50 mA)
Reverse Battery Protection	Yes	Indefinitely
Load Dump Protection	Yes	Energy Rated per SAE J1113
Channel Current Measurement Accuracy	+/- 0.5 amps	Typical
Channel Current Measurement Resolution	0.1amps	
Minimum Channel Current Measurement	0.5 amps	
PWM (all breakers)		
Frequency	200 Hz	
Load	Inductive load interface not recommended when PWM used	
Duty Cycle Range	5% - 100%	
Duty Cycle Resolution	1%	
Programmable Trip Level Resolution	1 amp	
Discrete Input Channels		
Input Resistance	1KΩ	
Input Voltage, Open Circuit	2.75 V	
Low Voltage Threshold	0 to 1.02 V	
Open Voltage Threshold	1.51 – 4.31 V	
High Voltage Threshold	4.82 – 32.0 V	

## MECHANICAL

PARAMETER	VALUE	COMMENT
Size	5.7" x 5.0" x 1.6" (144.8mm x 127mm x 40.6mm)	Including Flanges for Mounting
Weight	1.32 lb. (.599 kg)	
Power Stud Torque Value	20in.-lbs. (2.26 N.m)	

# 12-Channel Bypass Module

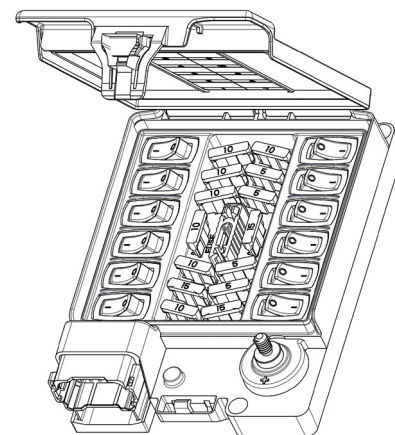
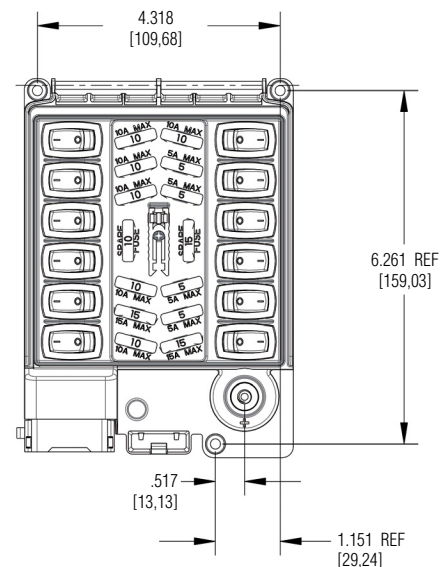


Installing the MPower® Bypass Module (CBMD12) in conjunction with the MPower 12-Channel DC Load Controller Module (CLMD12) provides owners/operators with the ability to manually control individual loads locally with a simple flip of a switch. The CBMD12 utilizes standard fuses for overcurrent protection and 12 Carling Curvette® Marine Rocker Switches for manual control of each load. One of the most popular styles used in general electrical applications, Curvette Rocker Switches are designed for extreme environments, corrosion, temperature, vibration, shock, and more. Extremely robust, Curvette switches are designed to last a minimum of 100,000 actuation cycles. This is a more reliable, safer and simpler process than physically moving a fuse while manually overriding a circuit.

It's important to ensure that the current rating of the fuse for each load is appropriate to protect the load and the wiring for that load. Please note that the Bypass Module does not support paralleled outputs since each circuit is controlled by a separate switch. Additionally, the Bypass Module does not support dimming of circuits.

## Product Features

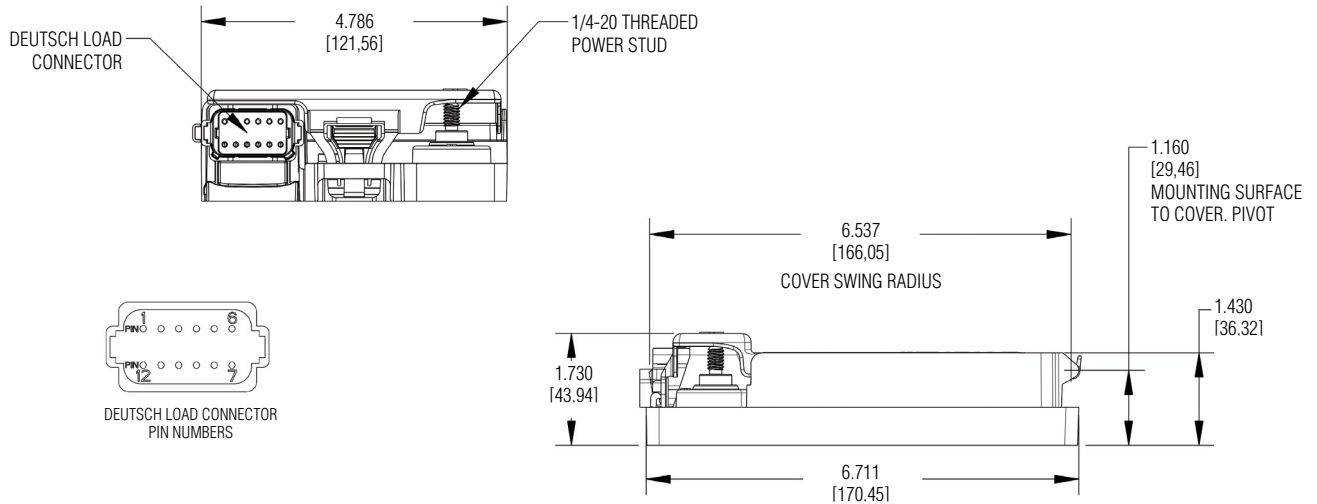
- 75 amps maximum current capacity
- Outputs
  - 12A max (two outputs)
  - 10A max (six outputs)
  - 5A max (four outputs)
- 12 & 24V DC power systems
- Carling Technologies Curvette® Rocker Switches
- Overcurrent protection via ATC standard fuses



## PRODUCT

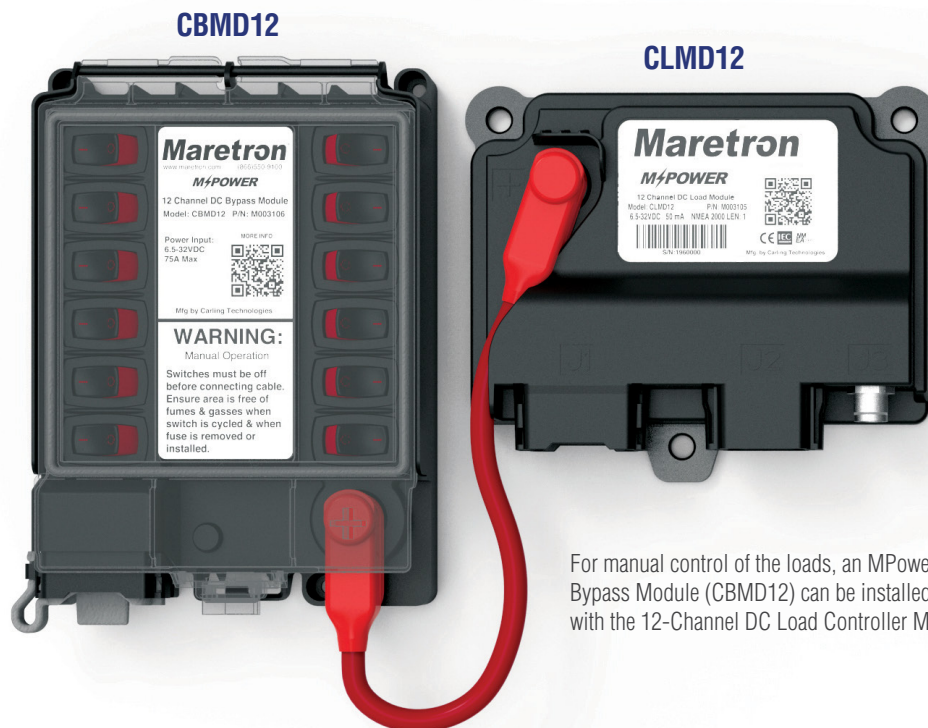
PART NUMBER	DESCRIPTION
CBMD12-R	12-Channel Bypass Module w/ Fuse Pack and Jumper Wire
CBMD12	12-Channel Bypass Module
A3720	Bypass Module Jumper Wire with Lugs, 6AWG, Red
A3721	Bypass Module Fuse Pack (2 qty 15A, 6 qty 10A and 4 qty 5A)

## Dimensional Specifications - Inch [mm]



PIN#	1	2	3	4	5	6	7	8	9	10	11	12
SWITCH#	1	2	3	4	5	6	12	11	10	9	8	7
CIRCUIT#	5	4	8	2	10	1	11	3	12	6	9	7
FUSE MAX RATING	10 AMP	12 AMP	10 AMP	10 AMP	10 AMP	10 AMP	10 AMP	5 AMP	5 AMP	5 AMP	5 AMP	12 AMP

## 12-Channel Bypass Module and 12-Channel DC Load Controller Module Installation



For manual control of the loads, an MPower 12-Channel Bypass Module (CBMD12) can be installed in conjunction with the 12-Channel DC Load Controller Module (CLMD12).



# 16-Channel DC Load Controller Module



For larger loads and more circuits, the MPower® CLMD16 is a 16-Channel DC Load Controller Module. Four of the 16 breakers handle a maximum of 25 amps and twelve breakers handle a maximum of 12 amps with a total current capacity of 125 amps. Additionally, circuits can be paralleled.

The CLMD16 also supports two 12A H-Bridge reversing polarity circuits that can be used for loads such as engine hatches, passerelles, trim tabs, etc. The CLMD16 has 8 inputs for hard-wired switches that can be used to switch breaker states, or as inputs for other data such as bilge alarms or hatch positions, etc. There are 2 resistive inputs and 1 current loop input that can be used for various applications including tank level monitoring.

The CLMD16 handles many DC load types such as lights, pumps, motors, and electronics. An added benefit of the CLMD16 is that it reports the current through each of the 16 breakers. This allows you to determine if loads are drawing too much or too little electrical current. This information can be used to report overcurrent faults and undercurrent conditions.

Monitor and control onboard electrical and electronic systems and reset circuits onboard and remotely with the following devices:

- Any 3rd party MFD that supports standard digital switching PGNs
- Maretron MBB300C Black Box
  - Garmin OneHelm™
  - Raymarine LightHouse 4
- Maretron TSM Series Dedicated Touchscreen
- MPower VMM6 Digital Switch Module
- MPower CKM12 Keypad
- Any device running Maretron's award-winning N2KView® V3 Software



## Product Features

- NMEA 2000® Interface
- IP67 Rated
- Ignition Protected
- Opto-Isolated from NMEA 2000, eliminating potential ground loops
- 16 Electronic Circuit Breakers (ECBs) for ON/OFF control over NMEA 2000 network
- 12 dimmable breakers
- 12 breakers carry 12 amps maximum, and 4 breakers are capable of carrying up to 25 amps
- Select breakers can be paralleled for larger loads.
- 2 sets of 12 amp breakers can be combined for reversing motor control
- Individual breaker electrical current monitoring
- Breakers can have power-up states defined (ON, OFF, or LAST STATE)
- Breakers can be locked against inadvertent actuation
- Capacitive touch switches for local control of all loads
- All inputs and outputs protected against short to power and short to ground
- Automatic ECB overcurrent shutdown
- Automatic ECB thermal shutdown (overtemperature protection)

## PRODUCTS

PART NUMBER	DESCRIPTION
CLMD16-R	16-Channel DC Load Controller Module w/A3708, A3709 & A3710
CLMD16	16-Channel Load Controller Module
A3708	Output (J2) Mating Connector with 1m Flying Leads
A3709	Output (J1) Mating Connector with 1m Flying Leads
A3710	J3 (I/O Gen Purpose) Harness Kit
DTP06-4S	J1 (Output) Mating Connector, Deutsch
0462-203-12141	J1 (Output) 14AWG Socket, Deutsch

PART NUMBER	DESCRIPTION
WP-4S	J1 (Output) Wedge, Deutsch
DT06-12SA	J2 (Output) Mating Connector, Deutsch
0462-209-16141	J2 (Output) 14AWG Socket, Deutsch
W12S	J2 (Output) Wedge, Deutsch
1028-043-1205	J2 Back Shell, 12 Way Plug, Deutsch
DRC26-24SA	J3 (I/O General Purpose) Mating Connector, Deutsch
0462-201-20141	J3 (I/O General Purpose) 16-20AWG Socket, Deutsch
0413-204-2005	J3 Connector Seal Plug, 20 HD SER, Deutsch

## SPECIFICATIONS

PARAMETER	VALUE
Number of Channels	16
Switching Voltage	< 32 VDC
Maximum Unit Current Capacity	125 amps
Maximum Channel Current Ratings	12x12A, 4x25A

## CERTIFICATIONS

PARAMETER	COMMENT
NMEA 2000	Certified
CE Mark	Recreational Craft Directive 2014/35/EU
Lloyd's Certification	Pending

## NMEA 2000® PARAMETER GROUP NUMBERS (PGNs)

DESCRIPTION	PGN#	PGN NAME	DEFAULT RATE
Periodic Data PGNs	127500	Load Controller Connection State & Control	1 time / 1.5 seconds and on switch change
	127501	Binary Status Report	1 time / 15 seconds and on switch change
	127751	DC Voltage / Current	1 time / 1.5 seconds
Response to Requested PGNs	126464	PGN List (Transmit and Receive)	N/A
	126720	Carling Proprietary	N/A
	126996	Product Information	N/A
	126998	Configuration Information	N/A
	130818	Maretron Proprietary	N/A
	130825	Maretron Proprietary	N/A
Protocol PGNs	059392	ISO Acknowledge	N/A
	059904	ISO Request	N/A
	060928	ISO Address Claim	N/A
	126208	NMEA Request/Command/Acknowledge	N/A
	126993	Heartbeat	1 time / 60 seconds
	130060	Label	N/A

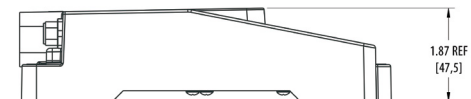
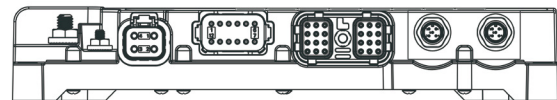
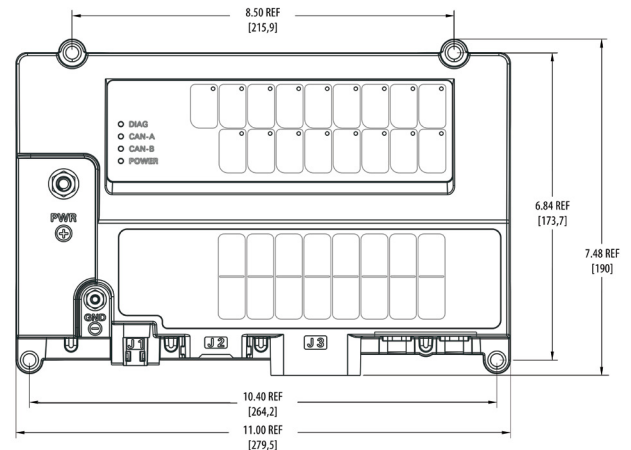
## ELECTRICAL

PARAMETER	VALUE	COMMENT
Voltage Input Range	8 to 32 VDC	DC Voltage
Power Consumption	50mA	NMEA 2000 Interface
Load Equivalence Number (LEN)	1	NMEA 2000 Spec. (1LEN = 50 mA)
Reverse Battery Protection	Yes	5 minutes
Load Dump Protection	Yes	12V: 87V, 200ms pulse, 1Ω impedance 24V: 173V, 100ms pulse, 2Ω impedance
12A ECB peak current capacity	120 A	
25A ECB peak current capacity	250 A	
Channel Current Measurement Accuracy	+/- 0.5 amps	Typical
Channel Current Measurement Resolution	0.1 amps	
Minimum Channel Current Measurement	0.5 amps	
PWM Frequency	200 Hz	Breakers 3, 4, 5, 6, 7, 8, 9, 10
	20 kHz	Breakers 1, 2, 11, 12
Load	Inductive load interface	
Duty Cycle Range	10% – 100%	
Duty Cycle Resolution	1%	
Programmable Trip Level Resolution	1% increments	Between 20% to 100% of Channel Capacity (12A or 25A)
Analog/Digital Input Channels		
Input Resistance	1KΩ	
Input Voltage, Open Circuit	2.75 V	
Alarm Output		
Maximum Supplied Current	300mA	
Resistive Input Measurement Accuracy	5 Ω	
Resistive Input Measurement Precision	2 Ω	
Resistive Input Measurement Resolution	1 Ω	

## MECHANICAL

PARAMETER	VALUE	COMMENT
Size	11.0" x 7.48" x 1.871" (279.4mm x 190.0mm x 47.5mm)	Including Flanges for Mounting
Weight	2.5 lb. (1.2 kg)	
Power Stud Torque Value	30 to 35 in-lbs. (3.39N-m - 3.95N-m)	
Ground Stud Torque Value	10 to 15 in-lbs. (1.13 -1.69N-m)	

## Dimensional Specifications - Inch [mm]



# VMM Series

## Contura® Digital Switch Module, 6 Rocker



The VMM6 is a sealed multiplexed, digital switch module featuring the Carling V-Series Contura® Rocker Switches. Well known for their cutting-edge design, high quality, maximum performance and unmatched reliability, the VMM6 Series reduces the complexity and cost of traditional wiring harnesses, increases product life and reliability, and reduces installation time. Available in six simple configurations, VMM6 is a plug-and-play solution that delivers switching technology at a very attractive price point.

For customers that want the option to source aftermarket actuators, we offer two versions of the VMM6 without actuators (Part numbers A3801-5, A3801-6).

### Product Features

- NMEA 2000® CAN Protocol
- IP68 Front Panel Sealing Protection
- Configurable
- Horizontal or Vertical Mounting Options
- Aftermarket Actuators Available
- LED Feedback of Circuit State
- Low Current Switching
- Tactile and Audible Feedback

### Front View

#### SEALING PROTECTION

Fully sealed IP68 front panel (when connected)



#### CUSTOMIZABLE ICONS

Choose from our standard selection of icons, or customize your own. Consult the factory for additional options.

#### ROCKERS

Variety of Carling V-Series Contura® actuators

### Back View

#### SEALING PROTECTION

Fully sealed IP68 back panel when connected and mating plug installed (included).



#### SNAP-IN MOUNTING

For fast, easy assembly

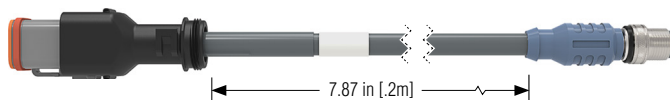
#### 4 PIN CONNECTOR

The included mating plug must be installed to meet IP68 Rating for back panel.

#### 6 PIN CONNECTOR

Mates to the VMM to NMEA 2000 Adapter Cable

### VMM to NMEA 2000® Adapter Cable - .2m (A3702)



### PRODUCTS

PART NUMBER	DESCRIPTION
A3801-1	Contura II (ALL Position Momentary ON) w/A3702
A3801-2	Contura II (Right Switch 3-Position) w/A3702
A3801-3	Contura V (All Positions Momentary ON) w/A3702
A3801-4	Contura V (Right Switch 3-Position) w/A3702
A3801-5	No Actuators (ALL Positions Momentary ON) w/A3702
A3801-6	No Actuators (Right Switch 3-Position) w/A3702

PART NUMBER	DESCRIPTION
A3702	VMM to NMEA 2000® Adapter Cable - .2m
A3702-1	VMM to NMEA 2000® Adapter Cable - 1m
A3702-2	VMM to NMEA 2000® Adapter Cable - .2m (90° Deutsch Connector)
A3702-3	VMM to NMEA 2000® Adapter Cable - 1m (90° Deutsch Connector)



## NMEA 2000® PARAMETER GROUP NUMBERS (PGNs)

DESCRIPTION	PGN#	PGN NAME	DEFAULT RATE
Periodic Data PGNs	127501	Binary Status Report	1 time / 15 seconds
Response to Requested PGNs	126464	PGN List (Transmit and Receive)	N/A
	126996	Product Information	N/A
	126998	Configuration Information	N/A
Protocol PGNs	059392	ISO Acknowledge	N/A
	055904	ISO Request	N/A
	060160	ISO Transport Protocol, Data Transfer	N/A
	060928	ISO Address Claim	N/A
	065240	ISO Address Command	N/A
	126208	NMEA Request/Command/Acknowledge	N/A
	126993	Heartbeat	1 time / 60 seconds
Carling Proprietary PGNs	061184	Device Configuration Information	N/A
	065226		N/A
	065300	Carling Flash Table Configuraton Response	N/A

## ELECTRICAL

PARAMETER	VALUE	COMMENT
Operating Voltage	9 to 32 Volts	DC Voltage
Power Consumption	150mA	NMEA2000® Interface
Load Equivalence Number (LEN)	3	NMEA2000® Spec. (1 LEN = 50mA)
Reverse Polarity Protection	Yes	-24V for 5 minutes
Electrical Endurance	250,000 operations	
Connector Type	Deutsch DT Series	

## MECHANICAL

PARAMETER	VALUE	COMMENT
Size	6.31" x 2.00" x 2.29" (160.27mm x 50.8mm x 58.17mm)	Includes Flanges for Mounting
Weight	8 oz. (227g)	

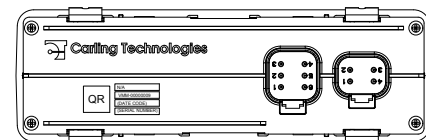
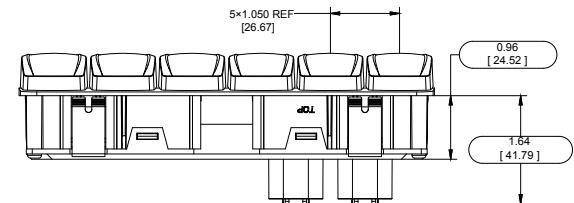
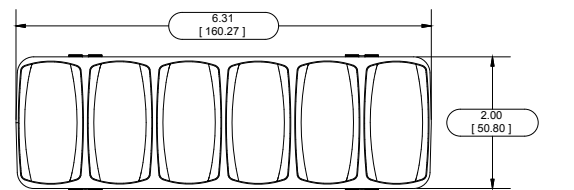
## ENVIRONMENTAL

PARAMETER	VALUE
Degree of Protection	IP68
Operating Temperature	-40°C – 85°C
Humidity, Soak	EN 60068-2-78 Test Cab, 30°C at 93% RH for 10 days
Vibration	EN 60068-2-6, swept sine wave from 5-500 Hz, ±15mm
Solar Radiation	EN 60068-2-5 Procedure B, 40°C for 10 days
Corrosion (Salt Mist)	EN 60068-2-52 Test Kb, severity level 4

## CERTIFICATIONS

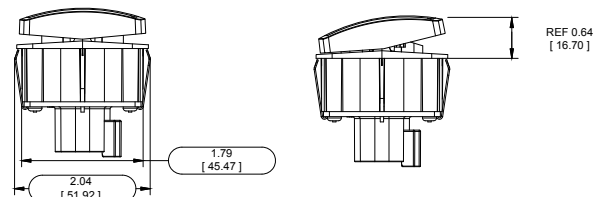
PARAMETER	COMMENT
NMEA 2000® Standard	Level A
CE Mark	Electromagnetic Compatibility

## Dimensional Specifications - Inch [mm]

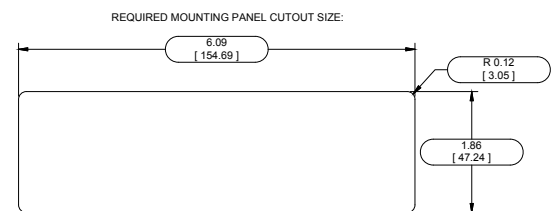


BUILT-IN RECEPTACLES COUPLE WITH DEUTSCH DT SERIES 4 AND 6 POSITION PLUGS

(4 POSITION RECEPTACLE RESERVED FOR FUTURE USE, PLUG INCLUDED)



REF 0.64 [16.70]



MINIMUM PANEL THICKNESS: 0.06 [1.57]

# CKM Series

## 12-Button Customizable Keypad



The CKM12 is a customizable keypad featuring laser-etched legends and LED function lights for each button. The LEDs also provide diagnostics when fault conditions are detected.

With the rugged mechanical packaging (IP69K), the CKM12 can be installed inside or outside the cabin. The low-profile design offers a seamless dashboard look and it can be mounted either vertically or horizontally.

The CKM12 offers significant advantages over traditional electromechanical switches such as longer actuation cycle (1,000,000), reduced wiring harness and reduced installation time. The CKM12 is sold off the shelf in two configurations and includes a CKM to NMEA 2000® Adapter Cable.

### Product Features

- NMEA 2000® CAN Protocol
- IP69K Front Panel Sealing Protection
- Configurable
- Diagnostic Feedback
- Standard or Custom Laser Etched Legends
- 1,000,000+ Button Actuation Cycles
- Low Current Switching
- Tactile and Audible Feedback

### Front View

#### LOW PROFILE DESIGN

.57 inch [14.48 mm] thickness  
(See dimensional specifications for more detail)

#### SEALING PROTECTION

IP69K front panel sealing protection



#### CUSTOMIZABLE ICONS

Choose from our standard selection of icons or customize your own. Consult the factory for additional options and minimum quantities for customization.

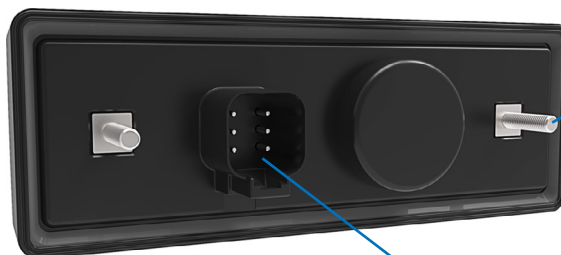
#### LED FUNCTION LIGHTS

Standard blue. Consult the factory for additional options.

### Back View

#### SEALING PROTECTION

Fully sealed IP68 back panel when connected



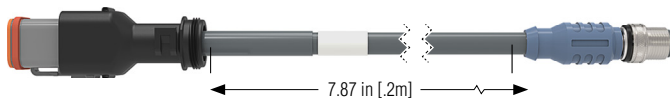
#### 10-32 MOUNTING STUDS (2X)

Max tightening torque 30 inch lbs.

#### CONNECTOR

Mates to the CKM to NMEA 2000® Adapter Cable

### CKM to NMEA 2000® Adapter Cable - .2m (A3703)



### PRODUCTS

PART NUMBER	DESCRIPTION
A3802-1	CKM12 Keypad (Circle on Buttons) w/A3703
A3802-2	CKM12 Keypad (Number in Center of Circle on Buttons) w/A3703
A3703	CKM to NMEA 2000® Adapter Cable - .2m

PART NUMBER	DESCRIPTION
A3703-1	CKM to NMEA2000® Adapter Cable - 1m
A3703-2	CKM to NMEA2000® Adapter Cable - .2m (90° Deutsch Connector)
A3703-3	CKM to NMEA2000® Adapter Cable - 1m (90° Deutsch Connector)

## NMEA 2000® PARAMETER GROUP NUMBERS (PGNs)

DESCRIPTION	PGN#	PGN NAME	DEFAULT RATE
Periodic Data PGNs	127501	Binary Status Report	1 time / 15 seconds
Response to Requested PGNs	126464	PGN List (Transmit and Receive)	N/A
	126996	Product Information	N/A
	126998	Configuration Information	N/A
Protocol PGNs	059392	ISO Acknowledge	N/A
	055904	ISO Request	N/A
	060160	ISO Transport Protocol, Data Transfer	N/A
	060416	ISO Transport Protocol, Connection Management	N/A
	060928	ISO Address Claim	N/A
	065240	ISO Address Command	N/A
	126208	NMEA Request/Command/Acknowledge	N/A
	126993	Heartbeat	1 time / 60 seconds
Carling Proprietary PGNs	061184	Device Configuration Information	N/A
	065300	Carling Flash Table Configuraton Response	N/A

## ELECTRICAL

PARAMETER	VALUE	COMMENT
Operating Voltage	8 to 32 Volts	DC Voltage
Power Consumption	150mA	NMEA2000® Interface
Load Equivalence Number (LEN)	3	NMEA2000® Spec. (1 LEN = 50mA)
Reverse Polarity Protection	Yes	-24V for 5 minutes
Electrical Endurance	1,000,000 operations	
Connector Type	Deutsch DT Series	

## MECHANICAL

PARAMETER	VALUE	COMMENT
Size	6.49" x 2.30" x 1.3" (164.85mm x 58.42mm x 33.02mm)	Includes Flanges for Mounting
Weight	.50 lb. (.23 kg)	

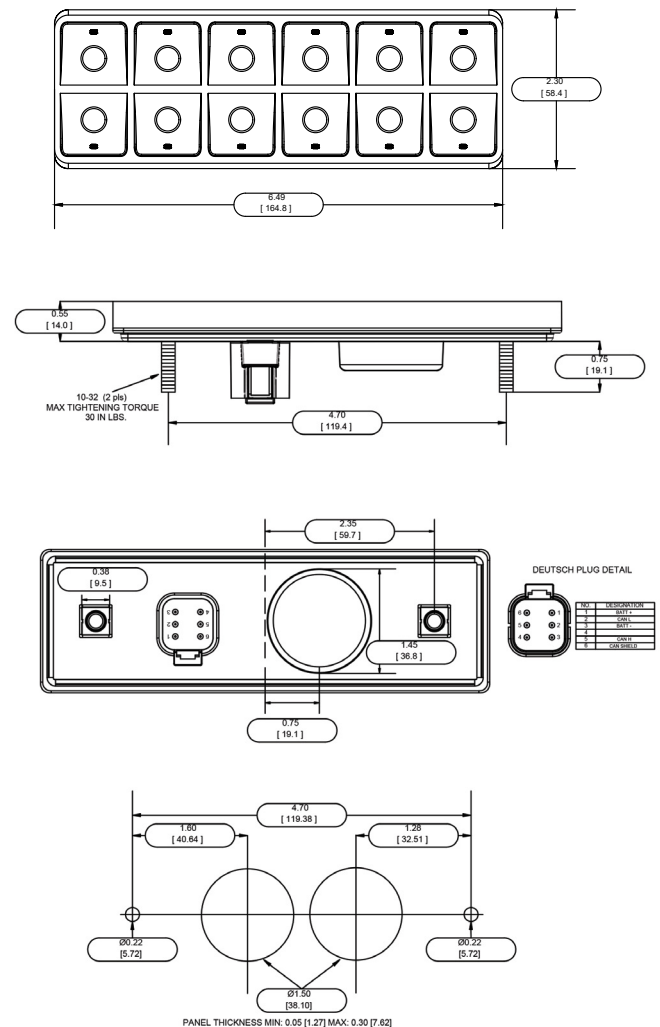
## ENVIRONMENTAL

PARAMETER	VALUE
Degree of Protection	IP6K9K (front), IP6K8 (back)
Operating Temperature	-40°C – 85°C
Humidity, Soak	EN 60068-2-78 Test Cab, 30°C at 93% RH for 10 days
Vibration	EN 60068-2-6, swept sine wave from 5-500 Hz
Solar Radiation	EN 60068-2-5 Procedure B, 10 cycles, Total irradiation per cycle = 22.4 kWh/m <sup>2</sup>
Corrosion (Salt Mist)	EN 60068-2-52 Test Kb, severity level 4

## CERTIFICATIONS

PARAMETER	COMMENT
NMEA 2000® Standard	Level A
CE Mark	Electromagnetic Compatibility

## Dimensional Specifications - Inch [mm]





# MConnect

## HTML5 Web Server

Designed for vessels of all sizes, the new MConnect® Web Server provides real time data on web pages that can be displayed on multiple phones, tablets, PCs or MACs—simultaneously. Following the design paradigm of Maretron's award-winning N2KView® Vessel Monitoring and Control Software, MConnect's engaging and informative graphic controls make it easy to display a large amount of critical data.

Pages can also be displayed on marine Multifunction Displays (MFDs) that support remote HTML servers such as Garmin OneHelm™ and Raymarine LightHouse 4 as well as full integration with digital switching systems such as Octoplex® and MPower®.

Through innovative use of color and high-definition graphics, the health of your boat is displayed at a glance as this information is seamlessly rolled up to other screens, bringing attention to potential problems. MConnect is fast, seamless, and easy to learn with an uncluttered interface that is customizable.

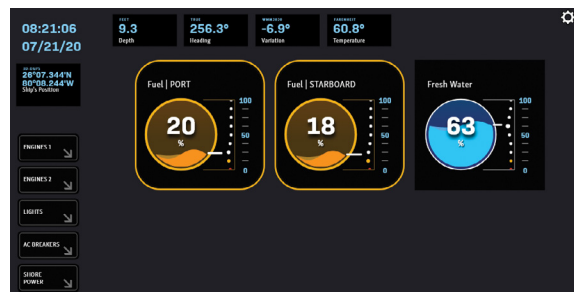
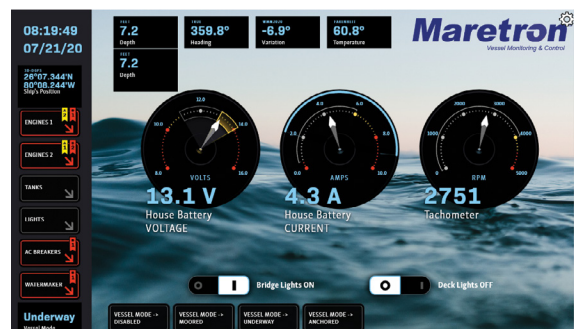
MConnect has direct connections to two NMEA 2000 busses, and receives data from both, independently. This means that MConnect can monitor Primary and Secondary busses, or independent Navigation and Monitoring busses without the need for a bridge.

With multiple simultaneous users, and a low price point, MConnect makes comprehensive vessel monitoring available to more users than ever before.

# MConnect

## Product features:

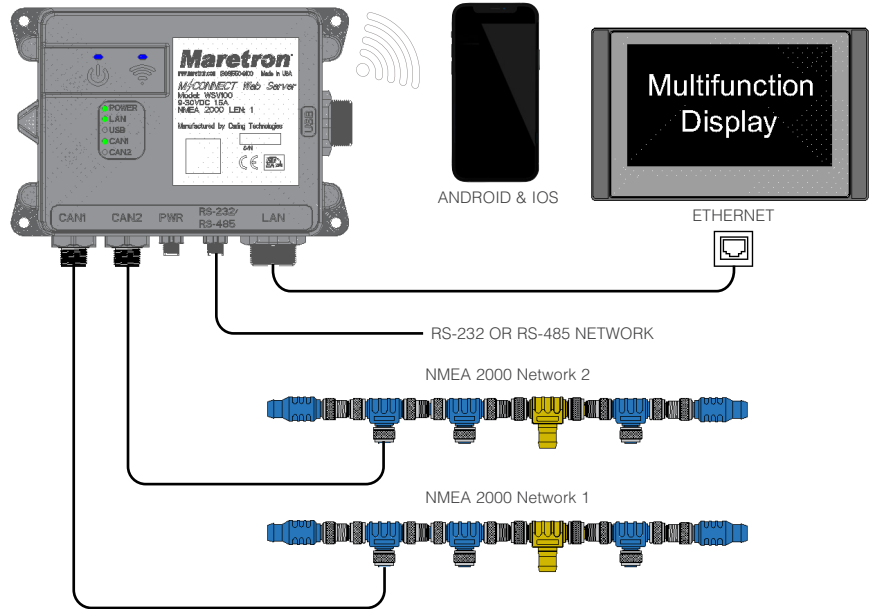
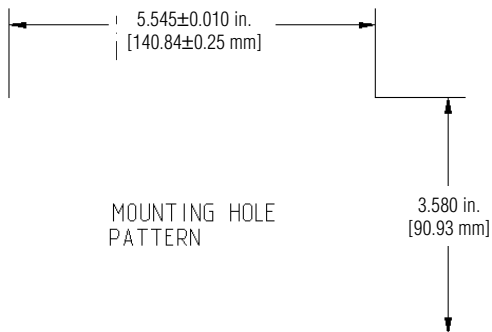
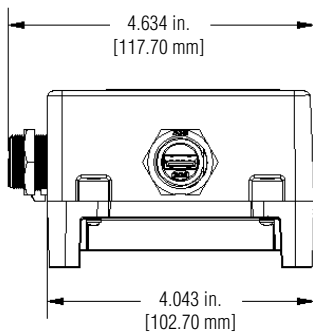
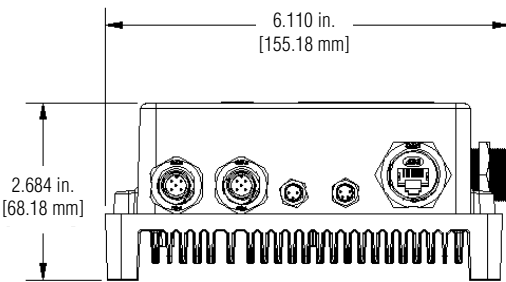
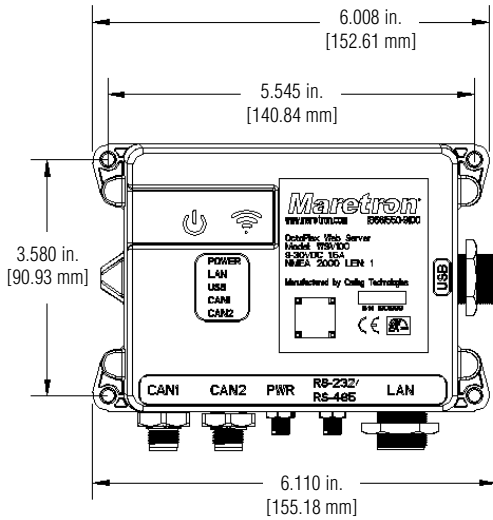
- IP67 Rated
- Dual CAN Bus for single or redundant NMEA 2000® Network Connections
- USB 3.0 Port
- RJ45 Ethernet Port
- Can support simultaneous access from up to (4) users
- 9-32 Volt Power Input (Reverse Polarity Protected)
- 5 Watt Power Usage
- Engaging HTML5 User Interface Experience



## PRODUCTS

PART NUMBER	DESCRIPTION
WSV100	MConnect HTML5 Web Server

# MConnect



## SPECIFICATIONS

PARAMETER	VALUE	COMMENT
(2) CAN Ports	NMEA 2000 Micro-C	For Connectivity to NMEA 2000
Serial Port	UART Interface	Switchable between RS-485 and RS-232 Protocols
USB Port	USB 3.0	For Software Updates and File Uploading
RJ45 Ethernet	1Gb/s	HTTP/HTTPS Port
Web Browser®	HTML5/JavaScript	To Support MFD Connectivity

## ELECTRICAL

PARAMETER	VALUE	COMMENT
Operating Voltage	9–32 Volts	DC Voltage (Dedicated Power Connection)
Power Consumption	5 Watts	Typical
Operating Voltage (NMEA 2000 Connection)	8–32 Volts	DC Voltage
Power Consumption (NMEA 2000 Connection)	50mA	1 LEN
Reverse Polarity Protection	Yes	NMEA 2000 & Power Connection

## MECHANICAL

PARAMETER	VALUE	COMMENT
Overall Dimensions (D x W x H)	2.68" x 6.00" x 4.04" (68.18 mm x 152.61 mm x 102.70mm)	Excluding Connectors
Weight	3 lbs. (1.36 kg)	
Mounting	Screw Mount	4 x #10 Screw Recommended, (Horizontal or Vertical Mounting Orientation)
Material	ABS Plastic Front Aluminum Back	
Heat Dissipation	Aluminum Heatsink	Air Cooled

## ENVIRONMENTAL

PARAMETER	VALUE
Operating Temperature	-20°C to 70°C
Storage Temperature	-40°C to 85°C
Ingress Protection	IP67

## CERTIFICATION

AGENCY
FCC Part 15
CE
NMEA 2000

# General Systems Monitoring and Recording

**Maretron general systems monitoring** and recording products are a system solution. The Switch Indicator Module (SIM100), can be used for monitoring both security and safety systems including magnetic door sensors, motion sensors or any other switch activated security sensor. The SIM100 can also be used for smoke, carbon monoxide, and combustible gas detection. Another good example of a general purpose monitor is the Temperature Module (TMP100). The TMP100 can be used for simple air

temperature measurement like cabin temperature, or it can be used to measure your engine's exhaust gas temperature indicating if the engine is running too lean or too rich. Further general monitoring products include the VDR100 data recorder that keeps track of everything that happens onboard your vessel. You can keep up to a year's worth of data on single USB thumb drive for review at anytime.



**SIM100**  
*Switch Indicator Module*



**FPM100**  
*Fluid Pressure Monitor*



**CLM100**  
*Current Loop Monitor*



**RAA100**  
*Rudder Angle Adapter*



**VDR100**  
*Vessel Data Recorder*



**TMP100**  
*Temperature Module*





# SIM100

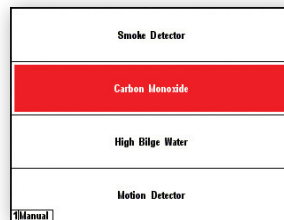
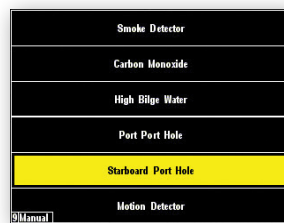
## Switch Indicator Module

The Switch Indicator Module monitors switch closure devices including, but not limited to, safety equipment (e.g., heat, smoke, carbon monoxide, explosive vapor detectors), security systems (e.g., motion, vibration, glass break, door and port hole magnetic switches), and vessel monitoring equipment (e.g., valve closed/open, high water bilge). The SIM100 continually monitors these switch closure devices and broadcasts information over the NMEA 2000® network about the switch state so the crew can be alerted to potential conditions or problems that warrant further investigation. Advanced features of the SIM100 include the ability to detect whether or not power has been disconnected from the monitored device or if the signal wires have been disconnected due to either corrosion, tampering, or for any other reason (if the monitored device is so equipped). With the SIM100, you can rest assured that critical sensors are receiving power, signal wires are connected, and all the safety, security and vessel functions are under constant supervision.

### Product Features

- Monitors and reports the running statuses of six independently connected devices
- Can detect and report problems like opens and shorts in switch circuits

Available accessories for the SIM100:



DSM Series Screen Shots



SH-003 Kit



SH-004 Kit



CO-CO1224T



BHW100



VS-07.0HG



IS216



MS-1085-N



MS-1035



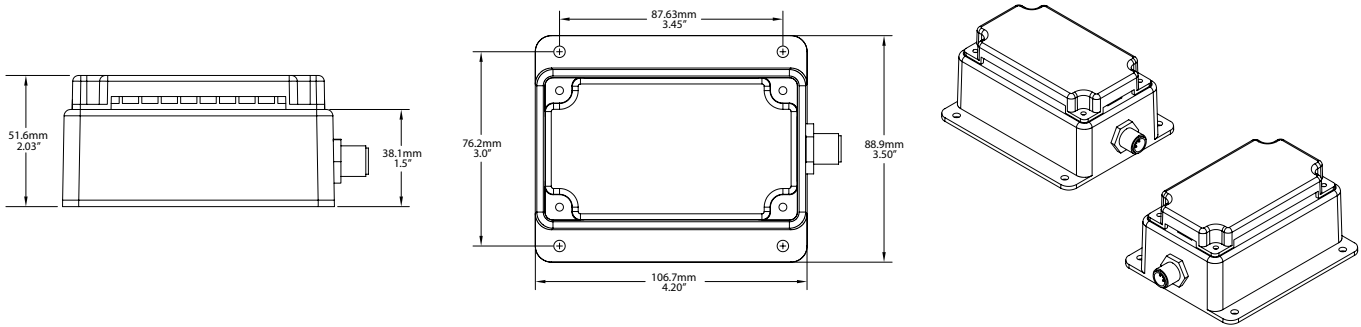
MS-1075



MS-1055-N

### PRODUCTS

PART NUMBER	DESCRIPTION
SIM100-01	Switch Indicator Module
SH-003	High Temp Smoke/Heat Detector Kit
SH-004	Photoelectric Smoke/Heat Detector Kit
SH-005	Ionization Smoke Detector & Sounder Kit
BHW100	Bilge High Water Detector
CO-CO1224T	Carbon Monoxide (CO) Detector (Surface Mount White)
IS216	Motion Detector
VS-07.0HG	Vacuum Switch (7" Hg or 24kPa)
MS-1035	Magnetic Switch Rectangular (Indoor)
MS-1085-N	Magnetic Switch Rectangular (Outdoor)
MS-1055-N	Magnetic Switch Cylinder (Indoor/Outdoor)
MS-1075	Magnetic Switch Recessed (Indoor/Outdoor)



## SPECIFICATIONS

PARAMETER	VALUE	COMMENT
End of Line Resistor	8 K $\Omega$ $\pm$ 5%	Included with Maretron-supplied sensors

## NMEA 2000® PARAMETER GROUP NUMBERS (PGNs)

DESCRIPTION	PGN#	PGN NAME	DEFAULT RATE
Periodic Data PGNs	127501	Binary Switch Bank Status	1 Time/15 seconds and on switch change
	130836	Switch Status Counter	1 Time/15 seconds and on switch change
	130837	Switch Status Timer	1 Time/15 seconds and on switch change
Response to Requested PGNs	126464	PGN List (Transmit and Receive)	N/A
	126996	Product Information	N/A
	126998	Configuration Information	N/A
Protocol PGNs	059392	ISO Acknowledge	N/A
	059904	ISO Request	N/A
	060928	ISO Address Claim	N/A
	065240	ISO Address Command	N/A
	126208	NMEA Request/Command/Acknowledge	N/A
Maretron Proprietary PGNs	126720	Device Configuration Information	N/A
	130818	Device Label	N/A

## ELECTRICAL

PARAMETER	VALUE	COMMENT
Operating Voltage	9 to 32 Volts	DC Voltage
Power Consumption	100mA	NMEA 2000® Interface
Load Equivalence Number (LEN)	2	NMEA 2000® Spec. (1LEN = 50mA)
Reverse Battery Protection	Yes	Indefinitely
Load Dump Protection	Yes	Energy Rated per SAE J1113

## MECHANICAL

PARAMETER	VALUE	COMMENT
Size	3.50" x 4.20" x 2.03" (88.9mm x 106.7mm x 51.6mm)	Including Flanges for Mounting
Weight	13 oz. (368.5 g)	

## ENVIRONMENTAL

PARAMETER	VALUE
IEC 60945 Classification	Exposed
Degree of Protection	IP64
Operating Temperature	-25°C to 55°C
Storage Temperature	-40°C to 70°C
Relative Humidity	93%RH @40° per IEC60945-8.2
Vibration	2-13.2Hz @ $\pm$ 1mm, 13.2-100Hz @ 7m/s <sup>2</sup> per IEC 60945-8.7
Solar Radiation	Ultraviolet B, A, Visible, and Infrared per IEC 60945-8.10
Corrosion (Salt Mist)	4 times 7days @ 40°C, 95%RH after 2 hour Salt Spray Per IEC 60945-8.12
Electromagnetic Emission	Conducted, Radiated Emission per IEC 60945-9
Electromagnetic Immunity	Conducted, Radiated, Supply, and ESD per IEC 60945-10
Safety Precautions	Dangerous Voltage, Electromagnetic Radio Frequency per IEC 60945-12

## CERTIFICATIONS

PARAMETER	COMMENT
NMEA 2000® Standard	Level A
Maritime Navigation and Radio Communication Equipment & Systems	IEC 61162-3
Maritime Navigation and Radio Communication Equipment & Systems	Tested to IEC 60945
FCC and CE Mark	Electromagnetic Compatibility

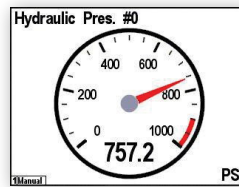
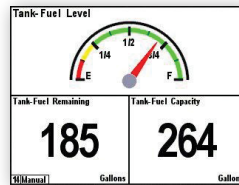


# FPM100

## Fluid Pressure Monitor

The Fluid Pressure Monitor is used to interface up to six pressure transducers to the NMEA 2000® network (pressure transducers sold separately). This allows you to observe fluid pressures and tank levels anywhere on the vessel where there are NMEA 2000 compatible displays. With the appropriate transducer, the FPM100 reports either pressure or vacuum for a variety of applications including water pressures, oil pressures, hydraulic pressures, or system vacuum for detecting clogged filters.

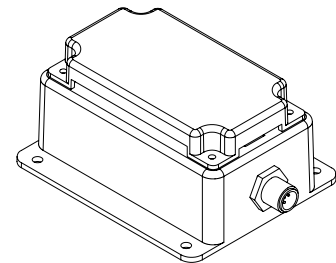
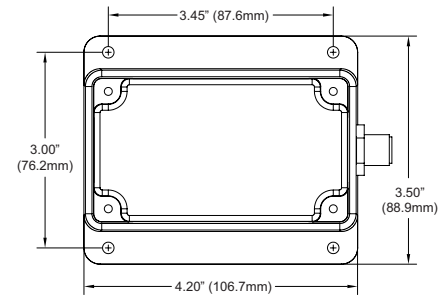
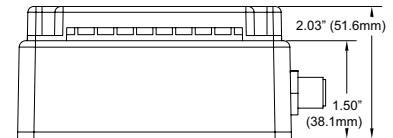
The FPM100 also has a tank level mode, so that fluid levels in a tank can be monitored via a pressure transducer mounted at the bottom of the tank and transmitted over the NMEA 2000 network. This allows you to monitor the fluid levels in tanks that are extremely deep, have internal structures, or are otherwise not suited for other tank level sensing technologies. In this mode, the FPM100 can be calibrated for irregular tank shapes so that you know the true level of the tanks.



DSM Series  
Screen Shots

### Product Features

- NMEA 2000® interface
- Interfaces up to six pressure transducers to the NMEA 2000 network
- Each channel independently programmable to match pressure transducer characteristics
- Each channel independently programmable in pressure/vacuum mode or tank level mode



### PRODUCTS

PART NUMBER	DESCRIPTION
FPM100-01	Fluid Pressure Monitor
PT-0-1.5PSI-01	Pressure Transducer 0 to 1.5 PSI
PT-0-3PSI-01	Pressure Transducer 0 to 3 PSI
PT-0-5PSI-01	Pressure Transducer 0 to 5 PSI
PT-0-10PSI-01	Pressure Transducer 0 to 10 PSI
PT-0-50PSI-01	Pressure Transducer 0 to 50 PSI
PT-0-100PSI-01	Pressure Transducer 0 to 100 PSI
PT-0-500PSI-01	Pressure Transducer 0 to 500 PSI

PART NUMBER	DESCRIPTION
PT-0-1000PSI-01	Pressure Transducer 0 to 1000 PSI
PT-0-5000PSI-01	Pressure Transducer 0 to 5000 PSI
PT-SNUB-01	Pressure Snubber
PT-V-0-1BAR-01	Pressure Transducer Vacuum to 1 Bar
PTS-0-1.5PSI-01	Submersible Pressure Transducer 0 to 1.5 PSI
PTS-0-3.0PSI-01	Submersible Pressure Transducer 0 to 3.0 PSI
PTS-0-5PSI-01	Submersible Pressure Transducer 0 to 5 PSI

Available accessories for the FPM100:



PT-0-xxxxPSI-01



PT-SNUB-01



PTS-0-x.xPSI-01

### SPECIFICATIONS (PRESSURE/VACUUM MODE)

PARAMETER	VALUE	COMMENT
Accuracy	+/-1% FS	Exclusive of Pressure Transducer
Resolution	+/-0.33% FS	Over Full Pressure Transducer Range
Number of Pressure Source Types	21	Water Pressure, Atmospheric Pressure, Compressed Air Pressure, Hydraulic Pressure, Steam Pressure, 16 User Defined Sources

### SPECIFICATIONS (TANK LEVEL MODE)

PARAMETER	VALUE	COMMENT
Accuracy	+/-1% FS	Exclusive of Pressure Transducer
Resolution	+/-0.33% FS	Over Full Pressure Transducer Range
Number of Tank Types	16	Fuel, Fresh Water, Waste water, Live well, Oil, etc.
Number of Tanks per Tank Type	16	16 Tanks per Tank Type Numbered 0-15
Support for Irregularly Shaped Tanks	Yes	Can be Calibrated for any Shape Tank
Programmable Tank Capacity	Yes	Allows Displays to Calculate Amount Remaining
Support for Irregularly Shaped Tanks	Yes	Can be Calibrated for any Shape Tank
Programmable Tank Capacity	Yes	Allows Displays to Calculate Amount Remaining

### NMEA 2000® PARAMETER GROUP NUMBERS (PGNs) See Appendix A for Details

DESCRIPTION	PGN#	PGN NAME	DEFAULT RATE
Periodic Data PGNs	127505	Fluid Level	0.4 Times/Second
	130314	Actual Pressure	0.5 Times/Second
Response to Requested PGNs	126464	PGN List (Transmit and Receive)	N/A
	126996	Product Information	N/A
	126998	Configuration Information	N/A
Protocol PGNs	059392	ISO Acknowledge	N/A
	059904	ISO Request	N/A
	060928	ISO Address Claim	N/A
	065240	ISO Address Command	N/A
	126208	NMEA Request/Command/Acknowledge	N/A
Maretron Proprietary PGNs	126720	Device Configuration Information	N/A
	130818	Device Label	N/A

### ELECTRICAL

PARAMETER	VALUE	COMMENT
Operating Voltage	9 to 32 Volts	DC Voltage
Power Consumption	400mA	Maximum Current Drain
Load Equivalence Number (LEN)	8	NMEA 2000® Spec. (1LEN = 50mA)
Reverse Battery Protection	Yes	Indefinitely
Load Dump Protection	Yes	Energy Rated per SAE J1113

### MECHANICAL

PARAMETER	VALUE	COMMENT
Size	3.50" x 4.20" x 2.03" (88.9mm x 106.7mm x 51.6mm)	Including Flanges for Mounting
Weight	13 oz. (368.5 g)	

### ENVIRONMENTAL

PARAMETER	VALUE
IEC 60945 Classification	Exposed
Degree of Protection	IP64
Operating Temperature	-25°C to 55°C
Storage Temperature	-40°C to 70°C
Relative Humidity	93%RH @40° per IEC60945-8.2
Vibration	2-13.2Hz @ ±1mm, 13.2-100Hz @ 7m/s² per IEC 60945-8.7
Solar Radiation	Ultraviolet B, A, Visible, and Infrared per IEC 60945-8.10
Corrosion (Salt Mist)	4 times 7days @ 40°C, 95%RH after 2 hour Salt Spray Per IEC 60945-8.12
Electromagnetic Emission	Conducted, Radiated Emission per IEC 60945-9
Electromagnetic Immunity	Conducted, Radiated, Supply, and ESD per IEC 60945-10
Safety Precautions	Dangerous Voltage, Electromagnetic Radio Frequency per IEC 60945-12

### CERTIFICATIONS

PARAMETER	COMMENT
NMEA 2000® Standard	Level A
Maritime Navigation and Radio Communication Equipment & Systems	IEC 61162-3
Maritime Navigation and Radio Communication Equipment & Systems	Tested to IEC 60945
FCC and CE Mark	Electromagnetic Compatibility

# RAA100

## Rudder Angle Adapter

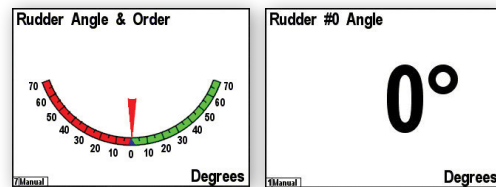
The RAA100 is used to adapt commercially available resistive rudder senders to the NMEA 2000® network. This allows you to observe rudder angle anywhere on the vessel where there are NMEA 2000 compatible displays such as the Maretron DSM Series.

The RAA100 is compatible with both the American standard (240-30 ohms) and European standard (10-180 ohm) resistive senders. In fact, the RAA100 can be calibrated for any resistance between 0 and 300 ohms.

You can also use the RAA100 with analog gauges at the same time as NMEA 2000 so you don't have to give up existing analog gauges to enjoy the advantages of digitally networked information.

### Product Features

- NMEA 2000® Interface
- Adapts American standard (240-30 ohm) resistive senders to NMEA 2000 Network
- Adapts European standard (10-180 ohm) resistive senders to NMEA 2000 Network
- Can be calibrated for any resistive sender ranging from 0-300 ohms or 300-0 ohms
- Three Point Electronic Calibration eliminates need for mechanical adjustment or calibration
- Can be used stand alone without analog gauges

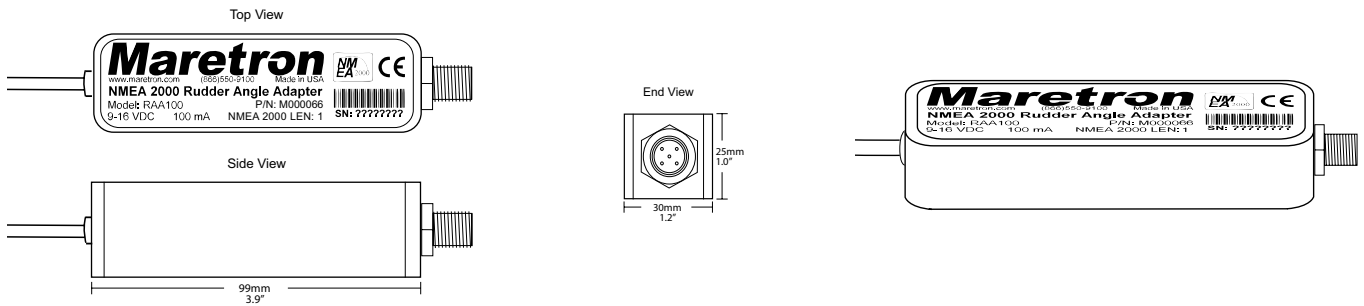


DSM Series Screen Shots

### PRODUCT

PART NUMBER	DESCRIPTION
RAA100-01	Rudder Angle Adapter





## SPECIFICATIONS

PARAMETER	VALUE	COMMENT
Accuracy	+/-2%	Does not include inaccuracies of analog gauge or sender
Resolution	+/-1%	Worst case (resolution better at high resistance values)
American Standard Senders	240–30 ohms	Standard sender types are User selectable
European Standard Senders	10–180 ohms	Standard sender types are user selectable
Calibration Resistance Range	0–300 ohms	Non-standard sender calibration
Electronic Calibration	Yes	Eliminates need to mechanically adjust or calibrate
Analog Gauge Support	Yes	Can be used with or without analog gauges

## NMEA 2000® PARAMETER GROUP NUMBERS (PGNs)

DESCRIPTION	PGN#	PGN NAME	DEFAULT RATE
Periodic Data PGNs	127245	Rudder	10 Times/Second
Response to Requested PGNs	126464	PGN List (Transmit and Receive)	N/A
	126996	Product Information	N/A
	126998	Configuration Information	N/A
Protocol PGNs	059392	ISO Acknowledge	N/A
	059904	ISO Request	N/A
	060928	ISO Address Claim	N/A
	065240	ISO Address Command	N/A
	126208	NMEA Request/Command/Acknowledge	N/A
Maretron Proprietary PGNs	126720	Device Configuration Information	N/A
	130818	Device Label	N/A

## ELECTRICAL

PARAMETER	VALUE	COMMENT
Operating Voltage	9 to 16 Volts	DC Voltage
Power Consumption	<50mA	Average Current Drain
Load Equivalence Number (LEN)	1	NMEA 2000® Spec. (1LEN = 50mA)
Reverse Battery Protection	Yes	Indefinitely
Load Dump Protection	Yes	Energy Rated per SAE J1113

## MECHANICAL

PARAMETER	VALUE	COMMENT
Size	3.9" x 1.2" x 1.0" (99mm x 30mm x 25mm)	Excluding NMEA 2000® Connector & Cable
Weight	9 oz. (255 g)	
Mounting	Any Orientation	

## ENVIRONMENTAL

PARAMETER	VALUE
IEC 60945 Classification	Exposed
Degree of Protection	IP67
Operating Temperature	-25°C to 55°C
Storage Temperature	-40°C to 70°C
Relative Humidity	93%RH @40° per IEC60945-8.2
Vibration	2-13.2Hz @ ±1mm, 13.2-100Hz @ 7m/s² per IEC 60945-8.7
Solar Radiation	Ultraviolet B, A, Visible, and Infrared per IEC 60945-8.10
Corrosion (Salt Mist)	4 times 7days @ 40°C, 95%RH after 2 hour Salt Spray Per IEC 60945-8.12
Electromagnetic Emission	Conducted, Radiated Emission per IEC 60945-9
Electromagnetic Immunity	Conducted, Radiated, Supply, and ESD per IEC 60945-10
Safety Precautions	Dangerous Voltage, Electromagnetic Radio Frequency per IEC 60945-12

## CERTIFICATIONS

PARAMETER	COMMENT
NMEA 2000® Standard	Level B+
Maritime Navigation and Radio Communication Equipment & Systems	IEC 61162-3
Maritime Navigation and Radio Communication Equipment & Systems	IEC 60945
FCC and CE Mark	Electromagnetic Compatibility

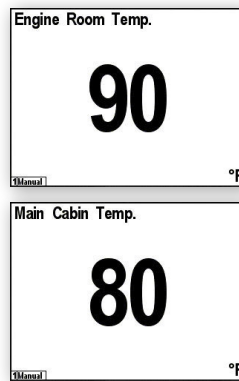
# TMP100

## Temperature Module

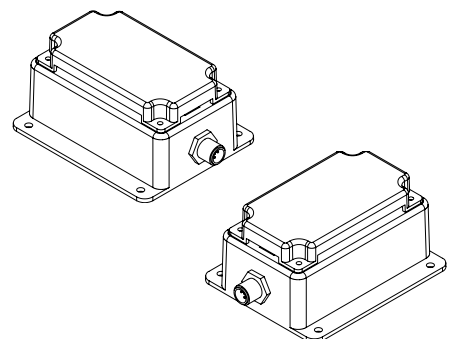
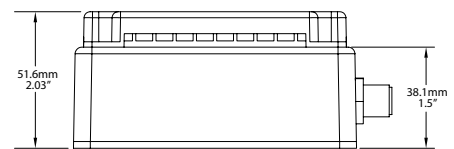
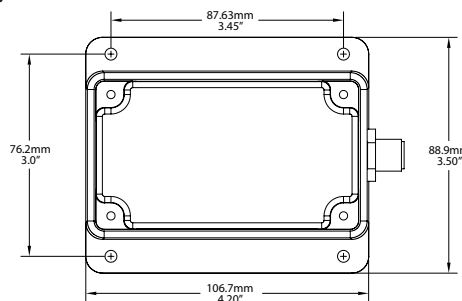
The TMP100 measures the temperature for up to 6 temperature probes and reports the information over an NMEA 2000® network. The TMP100 supports up to 4 thermistor probes and 2 high temperature thermocouple probes. Optional thermistor probes (-20°C to 80°C or -4°F to 176°F) cover a wide range of applications including cabin air temperature, engine room air temperature, refrigerator/freezer temperature, under bolt temperature (inverters, chargers, pumps, motors, etc.), tank temperatures (live well bait, hot water, etc.), and air duct temperatures. The optional thermocouple probes (0°C to 900°C or 32° to 1652°F) are used to measure Exhaust Gas Temperature (EGT) as part of a comprehensive fuel management system.

### Product Features

- Six external temperature probes are measured and broadcast over NMEA 2000® Network
- Four channels for thermistor probes and 2 channels for high temperature thermocouple probes
- Wide variety of applications supported with optional temperature probes
  - Cabin temperature
  - Engine room temperature
  - Under bolt temperature (inverters, chargers, pumps, etc.)
  - Refrigerator/freezer temperature
  - Tank temperatures (live bait well, hot water, etc.)
  - Air duct temperature
  - Exhaust gas temperature
- Optional temperature probes
  - Ambient air temperature probe (-20°C to 80°C or -4°F to 176°F)
  - Ring Terminal Probe (-20°C to 80°C or -4°F to 176°F)
  - Immersion probe for tanks or plenums (-20°C to 80°C or -4°F to 176°F)
  - Exhaust Gas Temperature Probe (0°C to 900°C or 32° to 1652°F)



DSM Series  
Screen Shots



### PRODUCTS

PART NUMBER	DESCRIPTION
TMP100-01	Temperature Module
TR3K	TMP100 Ring/Under Bolt Temperature Probe
TP-AAP-1	TMP100 Ambient Air Temperature Probe
TP-IP-1	TMP100 Immersion (Tanks, Plenums, etc.) Temperature Probe
TP-EGT-1	TMP100 Exhaust Gas Temperature (EGT) Probe

Available accessories for the TMP100:



TR3K



TP-AAP-1



TP-IP-1



TP-EGT-1

## SPECIFICATIONS

PARAMETER	VALUE	COMMENT
Number of Thermistor Channels	4	
Number of Thermocouple Channels	2	
Measurement Range – Thermistor	-20°C to 80°C (-4°F to 176° F)	With supplied thermistor probe
Measurement Accuracy – Thermistor	± 2°C (± 3.6°F)	With supplied thermistor probe
Measurement Range – Thermocouple	-0°C to 900°C (32°F to 1652° F)	With supplied thermocouple probe
Measurement Accuracy – Thermocouple	± 2°C (± 3.6°F)	With supplied thermocouple probe

## NMEA 2000® PARAMETER GROUP NUMBERS (PGNs)

DESCRIPTION	PGN#	PGN NAME	DEFAULT RATE
Periodic Data PGNs	130310	Environmental Parameters (not recommended for new designs; included for backward compatibility)	2 times/second
	130311	Environmental Parameters (not recommended for new designs; included for backward compatibility)	2 times/second
	130312	Temperature	0.5 times/second
	130316	Temperature, Extended Range	0.5 times/second
	130823	Temperature, High Range (Exhaust Gas Temperature) (Maretron Proprietary)	0.5 times/second
Response to Requested PGNs	126464	PGN List (Transmit and Receive)	N/A
	126996	Product Information	N/A
	126998	Configuration Information	N/A
Protocol PGNs	059392	ISO Acknowledge	N/A
	059904	ISO Request	N/A
	060928	ISO Address Claim	N/A
	065240	ISO Address Command	N/A
	126208	NMEA Request/Command/Acknowledge	N/A
Maretron Proprietary PGNs	126720	Device Configuration Information	N/A
	130818	Device Label	N/A

## ELECTRICAL

PARAMETER	VALUE	COMMENT
Operating Voltage	9 to 32 Volts	DC Voltage
Power Consumption	<50mA	NMEA 2000® Interface
Load Equivalence Number (LEN)	1	NMEA 2000® Spec. (1LEN = 50mA)
Reverse Battery Protection	Yes	Indefinitely
Load Dump Protection	Yes	Energy Rated per SAE J1113

## MECHANICAL

PARAMETER	VALUE	COMMENT
Size	3.50" x 4.20" x 2.03" (88.9mm x 106.7mm x 51.6mm)	Including Flanges for Mounting
Weight	13 oz. (368.5 g)	

## ENVIRONMENTAL

PARAMETER	VALUE
IEC 60945 Classification	Exposed
Degree of Protection	IP64
Operating Temperature	-25°C to 55°C
Storage Temperature	-40°C to 70°C
Relative Humidity	93%RH @40° per IEC60945-8.2
Vibration	2-13.2Hz @ ±1mm, 13.2-100Hz @ 7m/s² per IEC 60945-8.7
Solar Radiation	Ultraviolet B, A, Visible, and Infrared per IEC 60945-8.10
Corrosion (Salt Mist)	4 times 7days @ 40°C, 95%RH after 2 hour Salt Spray Per IEC 60945-8.12
Electromagnetic Emission	Conducted, Radiated Emission per IEC 60945-9
Electromagnetic Immunity	Conducted, Radiated, Supply, and ESD per IEC 60945-10
Safety Precautions	Dangerous Voltage, Electromagnetic Radio Frequency per IEC 60945-12

## CERTIFICATIONS

PARAMETER	COMMENT
NMEA 2000® Standard	Level A
Maritime Navigation and Radio Communication Equipment & Systems	IEC 61162-3
Maritime Navigation and Radio Communication Equipment & Systems	IEC 60945
FCC and CE Mark	Electromagnetic Compatibility



# CLM100

## Current Loop Monitor

The CLM100 converts commercially available 4-20mA current loop transducers into digital data so a wide variety of information can be displayed on Maretron displays. Numerous 4-20mA current loop transducers are supported by the CLM100 including transducers for monitoring DC voltage and current, flow rate, distance, linear velocity and acceleration, angle, angular velocity and acceleration, temperature, humidity, resistance, strain gauges, force (load cell), pressure, decibels, and rotational rate. Some typical applications where the CLM100 is used together with a commercial available 4-20mA transducers include machinery monitoring using accelerometers and vibration sensors. Vibration monitoring of pumps, motors, fans, compressors, and gear boxes provides an early warning of potential problems resulting in fewer breakdowns and reduced maintenance expenses. Another application example using the CLM100 is shaft speed monitoring. A commercially available 4-20mA rotational rate transducer is coupled to the shaft of interest and the CLM100 converts the transducer data to an RPM that can be read on a compatible NMEA 2000® display. And if you're concerned about the force exerted on a mast stay or perhaps a vessel tow attachment point, commercially available clevis pins with a 4-20mA interface can be connected to the CLM100 and the corresponding load monitored using any of Maretron's display products.

### Product Features

- Used together with commercially available 4–20mA current loop transducers
- Converts analog transducer data to digital Data (NMEA 2000®)
- Digital data displayed on Maretron displays



Available accessories for the CLM100:



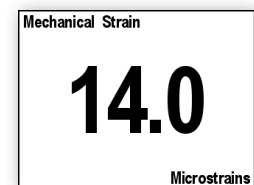
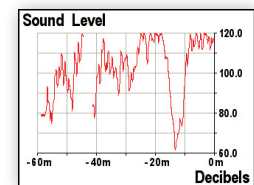
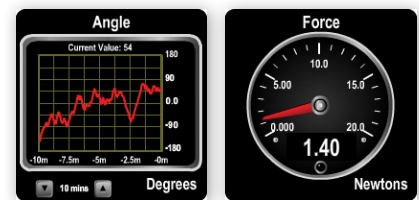
PT-0-xxxxPSI-01



PT-SNUB-01



IRHT-01

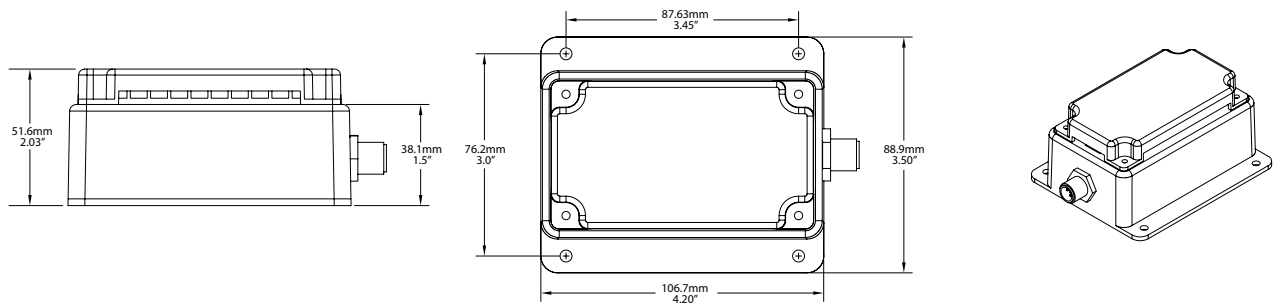


DSM Series Screen Shots

### PRODUCTS

PART NUMBER	DESCRIPTION
CLM100-01	Current Loop Monitor
IRHT-01	Indoor Humidity/Temperature Sensor
PT-0-1.5PSI-01	Pressure Transducer 0 to 1.5 PSI
PT-0-3PSI-01	Pressure Transducer 0 to 3 PSI
PT-0-5PSI-01	Pressure Transducer 0 to 5 PSI
PT-0-10PSI-01	Pressure Transducer 0 to 10 PSI
PT-0-50PSI-01	Pressure Transducer 0 to 50 PSI
PT-0-100PSI-01	Pressure Transducer 0 to 100 PSI

PART NUMBER	DESCRIPTION
PT-0-500PSI-01	Pressure Transducer 0 to 500 PSI
PT-0-1000PSI-01	Pressure Transducer 0 to 1000 PSI
PT-0-5000PSI-01	Pressure Transducer 0 to 5000 PSI
PT-SNUB-01	Pressure Snubber
PT-V-0-1BAR-01	Pressure Transducer Vacuum to 1 Bar
PTS-0-1.5PSI-01	Submersible Pressure Transducer 0 to 1.5 PSI
PTS-0-3PSI-01	Submersible Pressure Transducer 0 to 3 PSI
PTS-0-5PSI-01	Submersible Pressure Transducer 0 to 5 PSI



## SPECIFICATIONS

PARAMETER	VALUE	COMMENT
Number of Channels	6	Independently Programmable
Operating Modes	DC Voltage, DC Current, Flow Rate, Distance, Linear Velocity, Linear Acceleration, Angle, Angular Velocity, Angular Acceleration, Temperature, Humidity, Resistance, Strain Gauge, Force (Load Cell), Pressure, Decibels, Rotational Rate	
Transducer Interface	4-20mA current loop	
Current Loop Excitation Voltage	12-15 VDC	
Accuracy	+/-1% FS	Exclusive of Transducer
Resolution	+/-0.33% FS	Over Full Transducer Range

## NMEA 2000® PARAMETER GROUP NUMBERS (PGNs)

DESCRIPTION	PGN#	PGN NAME	DEFAULT RATE
Periodic Data PGNs	065286	Fluid Flow Rate (Maretron Proprietary)	2 Times/Second
	127488	Engine Parameters, Rapid Update	10 Times/Second
	127489	Engine Parameters, Dynamic	1 Time/Second
	127493	Transmission Parameters, Dynamic	10 Times/Second
	127508	Battery Status	0.67 Times/Second
	127751	DC Voltage/Current	0.67 Times/Second
	130313	Humidity	0.5 Times/Second
	130314	Actual Pressure	0.5 Times/Second
	130316	Temperature, Extended Range	0.5 Times/Second
	130576	Trim Tab Status	5 Times/Second
Response to Requested PGNs	130840	Generic Sensor (Maretron Proprietary)	1 Time/Second
	126464	PGN List (Transmit and Receive)	N/A
	126996	Product Information	N/A
Protocol PGNs	126998	Configuration Information	N/A
	059392	ISO Acknowledge	N/A
	059904	ISO Request	N/A
	060928	ISO Address Claim	N/A
	065240	ISO Address Command	N/A
Maretron Proprietary PGNs	126208	NMEA Request/Command/Acknowledge	N/A
	126720	Device Configuration Information	N/A
	130818	Device Label	N/A

## ELECTRICAL

PARAMETER	VALUE	COMMENT
Operating Voltage	9 to 32 Volts	DC Voltage
Power Consumption	400mA	Maximum Current Drain
Load Equivalence Number (LEN)	8	NMEA 2000® Spec. (1LEN = 50mA)
Reverse Battery Protection	Yes	Indefinitely
Load Dump Protection	Yes	Energy Rated per SAE J1113

## MECHANICAL

PARAMETER	VALUE	COMMENT
Size	3.50" x 4.20" x 2.03" (88.9mm x 106.7mm x 51.6mm)	Including Flanges for Mounting
Weight	13 oz. (368.5 g)	

## ENVIRONMENTAL

PARAMETER	VALUE
IEC 60945 Classification	Exposed
Degree of Protection	IP64
Operating Temperature	-25°C to 55°C
Storage Temperature	-40°C to 70°C
Relative Humidity	93%RH @40° per IEC60945-8.2
Vibration	2-13.2Hz @ ±1mm, 13.2-100Hz @ 7m/s <sup>2</sup> per IEC 60945-8.7
Solar Radiation	Ultraviolet B, A, Visible, and Infrared per IEC 60945-8.10
Corrosion (Salt Mist)	4 times 7days @ 40°C, 95%RH after 2 hour Salt Spray Per IEC 60945-8.12
Electromagnetic Emission	Conducted, Radiated Emission per IEC 60945-9
Electromagnetic Immunity	Conducted, Radiated, Supply, and ESD per IEC 60945-10
Safety Precautions	Dangerous Voltage, Electromagnetic Radio Frequency per IEC 60945-12

## CERTIFICATIONS

PARAMETER	COMMENT
NMEA 2000® Standard	Level A
Maritime Navigation and Radio Communication Equipment & Systems	IEC 61162-3
Maritime Navigation and Radio Communication Equipment & Systems	Tested to IEC 60945
FCC and CE Mark	Electromagnetic Compatibility

# VDR100

## Vessel Data Recorder

The Vessel Data Recorder (VDR100) is used to record messages transmitted from every product interconnected on the vessel's NMEA 2000® network. Recorded vessel data can be used in many ways including performance analysis, vessel tracking, preventative maintenance, network diagnostics, warranty incident, and accident investigation, all in an effort to reduce operating cost and improve safety.

Each message is stored using solid-state memory technology with simple data retrieval via a removable USB flash drive. The supplied 16GB USB Flash Drive will hold weeks or more of data, and with the optional purchase of a larger USB Flash Drive, a year or more of data can be stored. You'll never have to worry about losing the most recent data because the VDR100 uses a circular buffer where the oldest data is overwritten only after the entire memory is filled. Choose any or all of the recorded data including the associated dates and times and the program will create a comma delimited file (.csv) that can be read into a spreadsheet for graphing or any other type of data analysis.

As an example of how the recorded data might be used, consider an NMEA 2000 fuel flow monitor plugged into the network, which will provide a complete record of how much fuel was used and how fast it was used. With a GPS antenna/receiver plugged into the NMEA 2000 network, you will have a complete record of where the vessel has been, including its speed and course over ground. Analyzing or graphing recorded data is done using a spreadsheet program like Microsoft® Excel®. Simply remove the USB flash drive and plug it into a PC or Mac and run Maretron's free extraction software (N2KExtractor®).

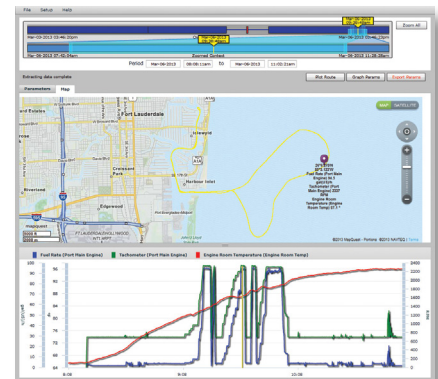


### PRODUCTS

PART NUMBER	DESCRIPTION
VDR100-01	Vessel Data Recorder
PX0852	USB Waterproof Cover
PX0837/5M00	Waterproof Ethernet Cable 16.4'
M003029	16GB USB Flash Drive

### Product Features

- Compact waterproof housing (IEC 60945 Maritime Navigation and Radio Communication Equipment)
- Data recorded on solid state memory via removable USB Flash Drive (included)
- Circular buffer preserves latest recorded data while oldest data is overwritten when memory is full
- Recorded data available for performance analysis, vessel tracking, preventive maintenance, and more
- Waterproof USB Flash Drive cover (included)
- Free data extraction software (N2KExtractor™) builds comma delimited files for your customized data analysis



N2KExtractor® Screen Shot

Available accessories for the VDR100:



PX0852

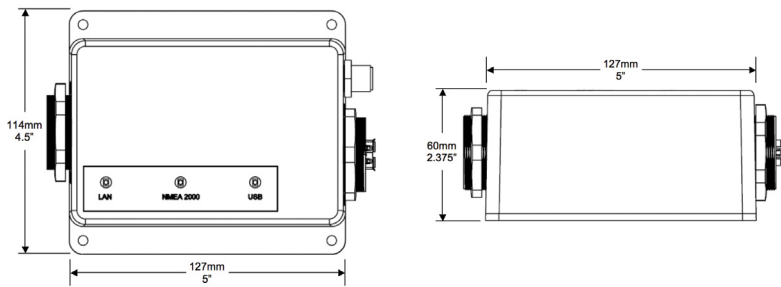


PX0837/5M00



M003029





## USB FLASH DRIVE SIZING GUIDELINES

RECORDING PERIOD	MEDIA STORAGE CAPACITY
1 second	7862 Bytes
1 minute	471,750 Bytes
1 hour	29 MB
1 day	680 MB
1 week	5 GB
1 month (30 days)	21 GB
1 year (365.25 days)	248 GB

Table figures are estimated assuming 25% loaded system (approximately 463 frames/sec) running continuously 24 hours/day, 7 days/week, 365 days/year.

## SPECIFICATIONS

PARAMETER	VALUE	COMMENT
NMEA 2000® Connector	DeviceNet Micro-C	Industry Standard Waterproof
NMEA 2000® Isolation	Opto-Isolated	No Electrical Connection Across Bridge
USB Standard	USB 2.0	
USB Connector	USB Type A	Industry Standard Waterproof, for Connection of USB Flash Memory Device for Recording Data
USB Supported Signals	D+, D-, +5V, GND	Bi-directional Gateway
USB Auxiliary Power	+5 Volts < 200mA	
USB Baud Rate	Up to 12 Mb/s	Full Speed USB Data Rate
Ethernet Interface	100 Mb/s	Allows network access using Maretron N2KExtractor®
Ethernet Connector	RJ-45	Industry Standard Waterproof

## NMEA 2000® PARAMETER GROUP NUMBERS (PGNs)

DESCRIPTION	PGN#	PGN NAME	DEFAULT RATE
Response to Requested PGNs	126464	PGN List (Transmit and Receive)	N/A
	126996	Product Information	N/A
	126998	Configuration Information	N/A
Protocol PGNs	059392	ISO Acknowledge	N/A
	059904	ISO Request	N/A
	060416	ISO Transport Protocol, Connection Management	N/A
	060160	ISO Transport Protocol, Data Transfer	N/A
	060928	ISO Address Claim	N/A
	065240	ISO Address Command	N/A
	126208	NMEA Request/Command/Acknowledge	N/A
PGNs Recorded	All	All	N/A

## ELECTRICAL

PARAMETER	VALUE	COMMENT
Operating Voltage	9 to 32 Volts	DC Voltage
Power Consumption	<200mA	Average Current Drain
Load Equivalence Number (LEN)	4	NMEA 2000® Spec. (1LEN = 50mA)
Reverse Battery Protection	Yes	Indefinitely
Load Dump Protection	Yes	Energy Rated per SAE J1113

## MECHANICAL

PARAMETER	VALUE	COMMENT
Size	5.000" x 4.5000" x 2.375" (127mm x 114mm x 60mm)	Including Flanges for Mounting
Weight	12 oz. (340 g)	

## ENVIRONMENTAL

PARAMETER	VALUE
IEC 60945 Classification	Exposed
Degree of Protection	IP67
Operating Temperature	-25°C to 55°C
Storage Temperature	-40°C to 70°C
Relative Humidity	93%RH @40° per IEC60945-8.2
Vibration	2-13.2Hz @ ±1mm, 13.2-100Hz @ 7m/s² per IEC 60945-8.7
Solar Radiation	Ultraviolet B, A, Visible, and Infrared per IEC 60945-8.10
Corrosion (Salt Mist)	4 times 7days @ 40°C, 95%RH after 2 hour Salt Spray Per IEC 60945-8.12
Electromagnetic Immunity	Conducted, Radiated, Supply, and ESD per IEC 60945-10
Safety Precautions	Dangerous Voltage, Electromagnetic Radio Frequency per IEC 60945-12

## CERTIFICATIONS

PARAMETER	COMMENT
NMEA 2000® Standard	Level A
Maritime Navigation and Radio Communication Equipment & Systems	IEC 61162-3
Maritime Navigation and Radio Communication Equipment & Systems	IEC 60945
FCC and CE Mark	Electromagnetic Compatibility

# Navigation Instruments

**State-of-the-art navigation begins with Maretron** award-winning instruments. Take our compass, for example. We were the first to bring solid-state compass technology to the marine industry, resulting in superior accuracy and incredible response time. The result—rock solid radar overlay on your

charting software and unprecedented autopilot performance. And of course, all our navigation instruments are engineered to the highest international marine standard (IEC 60945) for years of reliable service.



**WS0200**

*Ultrasonic Wind and Weather Station*



**GPS200**

*GPS Antenna/Receiver*



**SSC300**

*Solid State Compass*



NMMA Innovatoin Award



**DST110**

*Depth/Speed/Temperature Triducer*







# WSO200

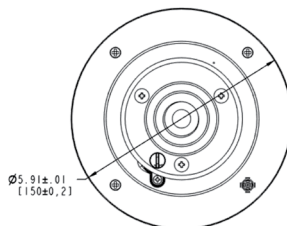
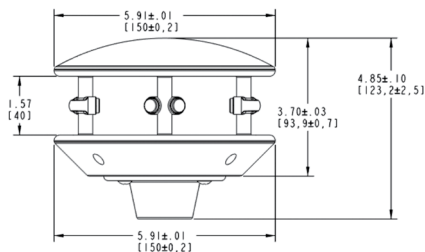
## Ultrasonic Wind and Weather Station

The second generation WSO200 is a marine grade ultrasonic weather station that accurately measures wind speed and direction, air temperature, barometric pressure, relative humidity, wind chill factor, heat index, and dew points. The wind measurement is calculated using six ultrasonic sensors in delta configuration, which means there are no moving parts to wear out or to get caught in the rigging. Unlike mechanical anemometers and weather measuring devices, the WSO200 is not affected by the common issues such as bearing wear, salt and dirt build-up, or bird perching that can all result in failure or data inaccuracy.

Precise wind speed and direction is easily achieved under tilt of up to 30°, as can be the case with heeled sailboats or powerboats operating in pitching and rolling seas. This makes the new Maretron weather station a gamechanger for recreational boaters.

The WSO200 is NMEA 2000® certified. When combined with a Maretron DSM Series or dedicated TSM Series display or any device running N2KView® V3 software, all data is visible on the NMEA 2000 network for a truly plug and play experience. Add a Maretron depth, speed & temperature triducer (DST110), a Maretron GPS receiver (GPS200), and a Maretron compass (SSC300) to view true vessel referenced wind speed and direction as well as ground referenced speed and direction.

The WSO200 mounts on a 1"-14 Standard Marine Mount and is waterproof to IP67 standards.

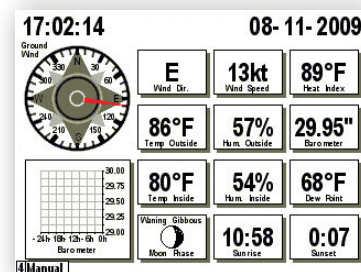
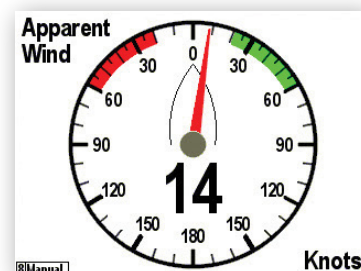


### The WSO200 provides these functions:

- Apparent Wind Speed
- Apparent Wind Direction
- Atmospheric Pressure
- Air Temperature
- Relative Humidity

### Second Generation Enhancements:

- User Replaceable Humidity Sensor
- Higher Signal to Noise Ratio
- Lower Power Consumption



DSM410 & DSM570 Screen Shots



N2KView Environment Screen

## PRODUCTS

PART NUMBER	DESCRIPTION
WSO200	Ultrasonic Wind/Weather Station

## SPECIFICATIONS

PARAMETER	VALUE	COMMENT
Wind Speed Range	0 to 99 knots (1 to 185 kph)	
Wind Speed Resolution	0.1 knot (0.19 kph)	
Wind Speed Accuracy	+/-10% or 1 knot (1.9kph)	Tilt 0° (operates to 30° tilt)
Wind Direction Accuracy	± 5°	Tilt 0° (operates to 30° tilt)
Temperature Range	-25° to 55° C	
Temperature Resolution	0.18°F (0.1°C)	
Temperature Accuracy	±1.8°F (1°C)	
Relative Humidity Range	0-99% RH	
Relative Humidity Resolution	1% RH	
Relative Humidity Accuracy	± 4% RH	
Barometric Pressure Range	26 to 32" HG (880 to 1080 mb)	
Barometric Pressure Resolution	0.03" HG (1 mb)	
Barometric Pressure Accuracy	±0.09" HG (±3 mb)	

## NMEA 2000® PARAMETER GROUP NUMBERS (PGNs)

PARAMETER	PGN#	PGN NAME	DEFAULT RATE
Periodic Data PGNs	130306	Wind Data	10 Times/Second
	130310	Environmental Parameters	10 Times/Second
	130311	Environmental Parameters	2 Times/Second
	130312	Temperature	2 Times/Second
	130313	Humidity	2 Times/Second
	130314	Actual Pressure	2 Times/Second
Response to Requested PGNs	126464	PGN List (Transmit and Receive)	N/A
	126996	Product Information	N/A
	126998	Configuration Information	N/A
Protocol PGNs	059392	ISO Acknowledge	N/A
	059904	ISO Request	N/A
	060416	ISO Transport Protocol, Connection Management	N/A
	060160	ISO Transport Protocol, Data Transfer	N/A
	060928	ISO Address Claim	N/A
	065240	ISO Address Command	N/A
	126208	NMEA Complex Request/Command/Ack.	N/A
Maretron Proprietary PGNs	126720	Device Configuration Information	N/A

## ELECTRICAL

PARAMETER	VALUE	COMMENT
Operating Voltage	9 to 32 Volts	DC Voltage
Power Consumption	<50mA	Average Current Drain
Load Equivalence Number (LEN)	1	NMEA 2000® Spec. (1LEN = 50mA)
Reverse Battery Protection	Yes	Indefinitely
Load Dump Protection	Yes	Energy Rated per SAE J1113

## MECHANICAL

PARAMETER	VALUE	COMMENT
Size	5.91" Dia. x 4.85" Tall (150mm Dia. x 123.2mm Tall)	Including Mounting Bracket
Weight	10 oz. (283g)	Including Mounting Bracket
Mounting	Pole	Fits 1"-14 TPI Standard Marine Mount

## ENVIRONMENTAL

PARAMETER	VALUE
IEC 60945 Classification	Exposed
Degree of Protection	IP67
Operating Temperature	-25°C to 55°C
Storage Temperature	-40°C to 70°C
Relative Humidity	93%RH @40° per IEC60945-8.2
Vibration	2-13.2Hz @ ±1mm, 13.2-100Hz @ 7m/s² per IEC 60945-8
Rain and Spray	12.5mm Nozzle @ 100liters/min from 3m for 30min per IEC 60945-8.8
Solar Radiation	Ultraviolet B, A, Visible, and Infrared per IEC 60945-8.10
Corrosion (Salt Mist)	4 times 7 days @ 40°C, 95%RH after 2 hour Salt Spray Per IEC 60945-8.12
Thermal Shock	10 cycles -25°C to +55°C. Total test time 80 hours, 2 hour soak at each temperature
Electromagnetic Emission	Conducted and Radiated Emission per IEC60945-9
Electromagnetic Immunity	Conducted, Radiated, Supply, and ESD per IEC 60945-10
Safety Precautions	Dangerous Voltage, Electromagnetic Radio Frequency per IEC 60945-12

## CERTIFICATIONS

PARAMETER	COMMENT
NMEA 2000® Standard	Certified
Maritime Navigation and Radio Communication Equipment & Systems	IEC 61162-3
Maritime Navigation and Radio Communication Equipment & Systems	EC 60945
FCC and CE Mark	Electromagnetic Compatibility

# GPS200

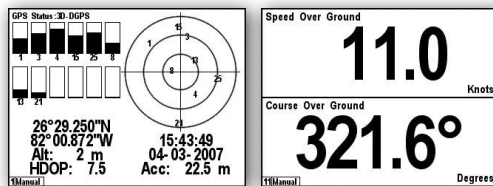
## GPS Antenna/Receiver

The second generation GPS200 is a state-of-the-art GPS/GLONASS antenna and receiver capable of producing ten position fixes per second. The GPS200 has unprecedented sensitivity and can even be mounted underneath a fiberglass deck. An additional benefit of the GPS200 is that it broadcasts precision magnetic variation information using the current position and world magnetic model (WMM2020).

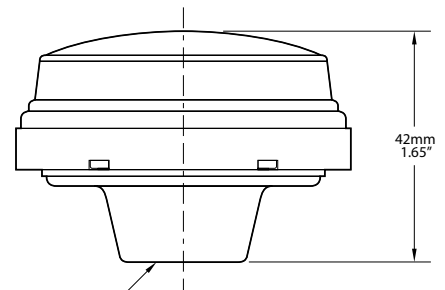
The GPS200 antenna/receiver is a plug-and-play device that is fully compliant and certified to the NMEA 2000® standard. It will directly connect to any NMEA 2000 network and communicate with navigational software, chartplotters, autopilots and dedicated instrument displays—such as Maretron's DSM Series Displays, or N2KView®—and its compact, waterproof housing provides years of reliable performance. The GPS200 automatically decodes GPS correction signals from Satellite Based Augmentation Systems (SBAS) including the North American Wide Area Augmentation System (WAAS), the European

Geostationary Navigation Overlay System (EGNOS), or the Asian Multi-functional Transport Satellite-based Augmentation System (MSAS) to provide better than 2.5m accuracy.

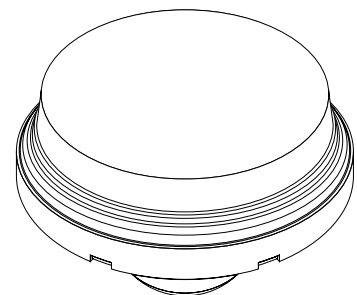
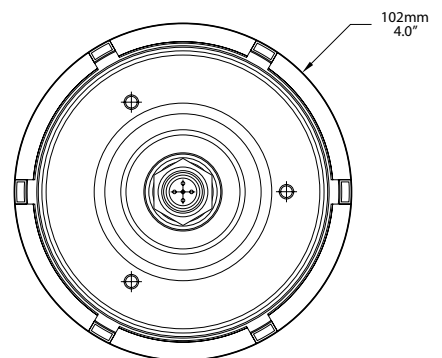
The GPS200 is easily mounted to a standard marine mount with 1"-14 TPI male pipe end. It can also be mounted directly to a deck.



DSM Series Screen Shots



1" - 14 - UNS-2B Thread  
(1" - 14 TPI Standard Marine Mount)



### PRODUCT

PART NUMBER	DESCRIPTION
GPS200-01	GPS Antenna/Receiver



## SPECIFICATIONS

PARAMETER	VALUE	COMMENT
Supported Positioning Systems	GPS, GLONASS	Simultaneously
Position Accuracy (Autonomous)	<3m	2D RMS
Position Accuracy (WAAS)	<2.5m	2D RMS (depends on accuracy of correction data)
Channels	99	33 Tracking, 99 Acquisition
Tracking Sensitivity	-161dBm	
Position Update Rate	10 per Second	10 Hz Position Fix Calculation Rate
Speed Update Rate	10 per Second	
Time Update Rate	1 per Second	
Hot Start	1 Seconds	Start Within Hours of Last Power Down
Cold Start	33 Seconds	Start from Unknown Position
Satellite Based Augmentation System	WAAS	North America
EGNOS	Europe	
MSAS	Asia	
GAGAN	India	
Altitude Limit	18000 m	
Velocity Limit	515 m/sec	
Battery Backup	Lithium (4-5 Days)	Holds Position for Hot Starts

## NMEA 2000® PARAMETER GROUP NUMBERS (PGNs)

DESCRIPTION	PGN#	PGN NAME	DEFAULT RATE
Periodic Data PGNs	126992	System Time	1 Time/Second
	128259	Speed	Disabled
	129025	Position, Rapid Update	5 Times/Second
	129026	COG and SOG, Rapid Update	4 Times/Second
	129029	GNSS Position Data	1 Time/Second
	129539	GNSS DOPs	1 Time/Second
	129540	GNSS Satellites in View	1 Time/Second
Response to Requested PGNs	127258	Magnetic Variation	1 Time/Second
	126464	PGN List (Transmit and Receive)	N/A
	126996	Product Information	N/A
	126998	Configuration Information	N/A
	129538	GNSS Control Status	N/A
Protocol PGNs	129541	GPS Almanac Data	N/A
	059392	ISO Acknowledge	N/A
	059904	ISO Request	N/A
	060416	ISO Transport Protocol, Connection Management	N/A
	060160	ISO Transport Protocol, Data Transfer	N/A
	060928	ISO Address Claim	N/A
Maretron Proprietary PGNs	065240	ISO Address Command	N/A
	126720	Device Configuration Information	N/A
	130818	Device Label	N/A

## ELECTRICAL

PARAMETER	VALUE	COMMENT
Operating Voltage	9 to 32 Volts	DC Voltage
Power Consumption	<150mA	Average Current Drain
Load Equivalence Number (LEN)	3	NMEA 2000® Spec. (1LEN = 50mA)
Reverse Battery Protection	Yes	Indefinitely
Load Dump Protection	Yes	Energy Rated per SAE J1113

## ENVIRONMENTAL

PARAMETER	VALUE
IEC 60945 Classification	Exposed
Degree of Protection	IP67
Operating Temperature	-25°C to 55°C
Storage Temperature	-40°C to 70°C
Relative Humidity	93%RH @40° per IEC60945-8.2
Vibration	2-13.2Hz @ ±1mm, 13.2-100Hz @ 7m/s² per IEC 60945-8.7
Solar Radiation	Ultraviolet B, A, Visible, and Infrared per IEC 60945-8.10
Corrosion (Salt Mist)	4 times 7days @ 40°C, 95%RH after 2 hour Salt Spray Per IEC 60945-8.12
Electromagnetic Emission	Conducted, Radiated Emission per IEC 60945-9
Electromagnetic Immunity	Conducted, Radiated, Supply, and ESD per IEC 60945-10
Safety Precautions	Dangerous Voltage, Electromagnetic Radio Frequency per IEC 60945-12

## MECHANICAL

PARAMETER	VALUE	COMMENT
Size	4" Diameter x 1.65" Tall	Not Including Antenna Mount Base
Weight	6 oz.	Not Including Antenna Mount Base
Mounting	Deck or Pole	Fits 1"-14 TPI Standard Marine Mount

## CERTIFICATIONS

PARAMETER	COMMENT
NMEA 2000®	Level A
Maritime Navigation and Radio Communication Equipment & Systems	Tested to IEC 60945
FCC and CE Mark	Electromagnetic Compatibility

# SSC300

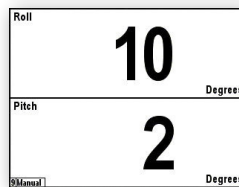
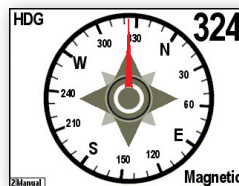
## Solid State Compass

Implementing the second generation award-winning solid state compass technology, the SSC300 is a solid state, rate gyro electronic compass that provides better than 0.7° heading accuracy through ±45° of roll and pitch angle, and better than 1° roll and pitch accuracy in static conditions. Each SSC300 is factory calibrated for maximum accuracy. It delivers precise, reliable heading and rate of turn information twenty times per second, and vessel attitude including pitch and roll readings ten times per second. A micromachined 3-axis rate gyro is used in conjunction with the 3-axis accelerometer by advanced stabilization algorithms to provide accurate, stable readings during dynamically changing conditions such as hard turns or rough seas, making it an ideal heading sensor for autopilot or radar overlay applications.

The SSC300 is certified to the NMEA 2000® network standard and compatible with the NMEA 0183 digital interface standard. It connects directly with any NMEA 2000 network, and, with the optional NMEA 0183 cable accessory, with NMEA 0183 Listeners to share information with navigational software, chart plotters, autopilots, and dedicated instrument displays—including Maretron graphical displays and N2KView® software.

### Product Features

- Better than 0.7° heading accuracy in status conditions
- Better than 1.5° heading accuracy in dynamic conditions
- Better than 1°/second rate of turn accuracy
- Better than 1° pitch/roll accuracy
- Three-axis magnetometer, Three-axis rate gyro, and Three-axis accelerometer
- Outputs NMEA 0183 and NMEA 2000® data simultaneously (optional NMEA 0183 cable accessory required for NMEA 0183 output)
- IP67 waterproof enclosure

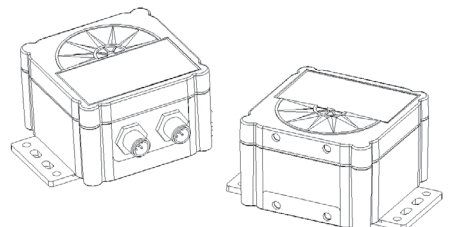
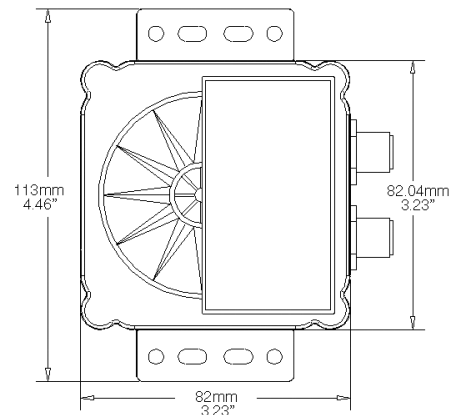
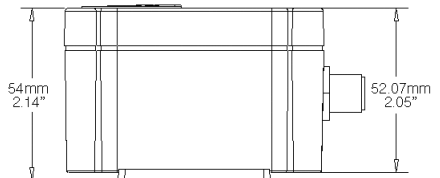


DSM Series Screen Shots

Available accessories for the SSC300:



MARE-004



### PRODUCTS

PART NUMBER	DESCRIPTION
SSC300-01	Solid-State Rate/Gyro Compass
MARE-004	SSC300 Compass NMEA 0183 10 meter Connection Cable

## SPECIFICATIONS

PARAMETER	VALUE	COMMENT
Static Heading Accuracy	<0.7° RMS	±45° Pitch and Roll - 15°C to 35°C
Heading Display Resolution	0.1°	With Maretron Display
Settling Time	1 Second	To Static Accuracy after 35°/Second Turn
Heading Update Rate	20 per Second	
Heading Deviation	Yes	Automatic
Alignment Calibration	Yes	In Boat Calibration with Maretron Displays
Pitch and Roll Range	±80°	With Maretron Display
Pitch and Roll Accuracy	<1°	±45° Pitch and Roll - 15°C to 35°C
Pitch and Roll Display Resolution	0.1°	With Maretron Display
Pitch and Roll Update Rate	10 per Second	
Pitch and Roll to Boat Alignment	Yes	In Boat Calibration with Maretron Displays
Rate of Turn Range	0° - 90°/ Second	At 0° Pitch and Roll
Rate of Turn Accuracy	±1° per Second	0° Pitch and Roll - 15°C to 35°C
Rate of Turn Update Rate	10 per Second	
NMEA 0183 Standard	Compatible	Up to 38,400 Baud (40 Hz Update Rate)

## NMEA 2000® PARAMETER GROUP NUMBERS (PGNs)

DESCRIPTION	PGN#	PGN NAME	DEFAULT RATE
Periodic Data PGNs	127250	Vessel Heading	10 Times/Second
	127257	Attitude	1 Time/Second
	127251	Rate of Turn	10 Times/Second
Response to Requested PGNs	126464	PGN List (Transmit and Receive)	N/A
	126996	Product Information	N/A
	126998	Configuration Information	N/A
Protocol PGNs	059392	ISO Acknowledge	N/A
	059904	ISO Request	N/A
	060416	ISO Transport Protocol, Connection Management	N/A
	060160	ISO Transport Protocol, Data Transfer	N/A
	060928	ISO Address Claim	N/A
	065240	ISO Address Command	N/A
	126208	NMEA Request/Command/Acknowledge	N/A
Maretron Proprietary PGNs	126720	Device Configuration Information	N/A
	130818	Device Label	N/A

## NMEA 0183 SENTENCES

SENTENCE	ACRONYM	SENTENCE NAME	DESCRIPTION
Transmitted Sentences	HDG	Heading, Deviation, and Variation	10 Times/Second
	HDM	Heading, Magnetic	N/A
	HDT	Heading, True	N/A
	ROT	Rate of Turn	5 Times/Second
	PMAROUT	Maretron Proprietary Attitude (Pitch and Roll)	1 Time/Second
	TXT	Text Transmission	N/A
Received Sentences	RMC	Recommended Minimum Specific GNSS Data	N/A
	VTG	Course Over Ground and Ground Speed	N/A

## ELECTRICAL

PARAMETER	VALUE	COMMENT
Operating Voltage	9 to 16 Volts	DC Voltage
Power Consumption	<50mA	Average Current Drain
Load Equivalence Number (LEN)	1	NMEA 2000® Spec. (1LEN = 50mA)
Reverse Battery Protection	Yes	Indefinitely
Load Dump Protection	Yes	Energy Rated per SAE J1113

## MECHANICAL

PARAMETER	VALUE	COMMENT
Size	4.46" x 3.23" x 2.14" 113mm x 82mm x 54mm	Including Mounting Flanges
Weight	7 oz. (198 g)	Including Mounting Bracket
Mounting	Deck or Bulkhead	

## ENVIRONMENTAL

PARAMETER	VALUE
IEC 60945 Classification	Exposed
Degree of Protection	IP67
Operating Temperature	-25°C to 55°C
Storage Temperature	-40°C to 70°C
Relative Humidity	93%RH @40° per IEC60945-8.2
Vibration	2-13.2Hz @ ±1mm, 13.2-100Hz @ 7m/s² per IEC 60945-8.7
Rain and Spray	12.5mm Nozzle @ 100 liters/min from 3m for 30min per IEC 60945 8.8
Solar Radiation	Ultraviolet B, A, Visible, and Infrared per IEC 60945-8.10
Corrosion (Salt Mist)	4 times 7days @ 40°C, 95%RH after 2 hour Salt Spray Per IEC 60945-8.12
Electromagnetic Immunity	Conducted, Radiated, Supply, and ESD per IEC 60945-10
Safety Precautions	Dangerous Voltage, Electromagnetic Radio Frequency per IEC 60945-12

## CERTIFICATIONS

PARAMETER	COMMENT
NMEA 2000® Standard	Level A
Maritime Navigation and Radio Communication Equipment & Systems	EC 61162-3
Maritime Navigation and Radio Communication Equipment & Systems	IEC 60945
FCC and CE Mark	Electromagnetic Compatibility



# DST110

## Depth/Speed/Temperature Triducer

The DST110 Smart™ Retractable Depth/Speed/Temperature Transducer delivers precise digital depth, accurate speed and exact water temperature even at speeds above 40 knots.

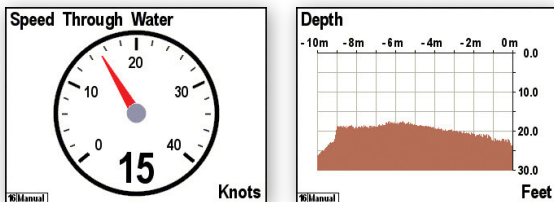
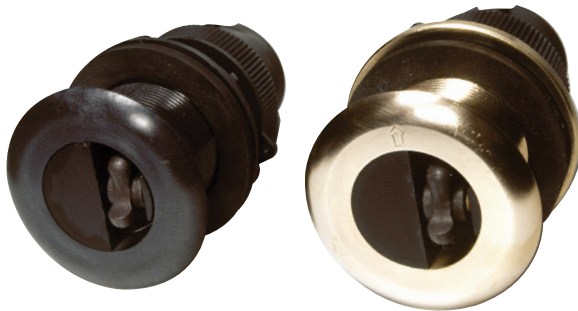
Its patented Smart™ Sensor technology, retractable and removable sensor, and NMEA 2000® network connectivity make the DST110 easy to interpret, easy to install and connect with other navigation equipment, and easy to maintain.

The DST110 measures precise water depth at 0.4m to 100m with a wide beam width and is tolerant to most deadrise angles. It reads water temperature from -10°C to +40°C at ±1.0°C accuracy and accurate speed from 1 to 50 knots. User customizable calibrations for speed and temperature allow you to adjust speed and temperature indications for your installation. At 235 kHz, it can be used with a fish finder as an ideal navigation tool for sport or commercial fishing vessels or with sailing vessels of all sizes.

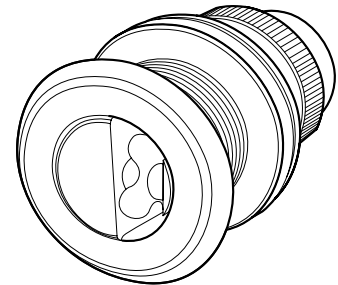
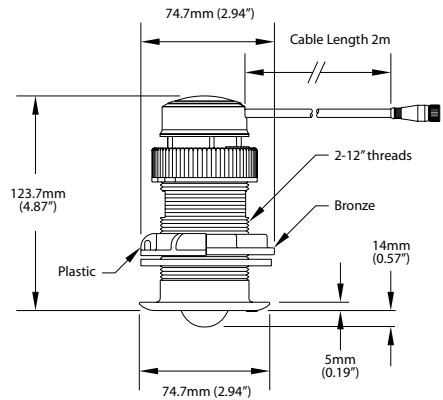
The DST110's plastic or bronze choices are compatible with any hull material. It includes a blank plug to replace its sensor unit when the vessel will

be docked for extended periods or trailored. This prevents damage to the sensor and reduces fouling growth.

The DST110 is CE compliant (IEC 60945) and is manufactured to the highest quality standards under ISO9K/2K procedures. Its compact, waterproof housing will provide years of reliable performance, making it the Smart™ choice in marine sensing.



DSM Series Screen Shots



Available accessories for the SSC300:



M33-100



33-398-04PW

### PRODUCTS

PART NUMBER	DESCRIPTION
DST110-01	Depth/Speed/Temperature Triducer® (100 Meter Depth)
M33-100	Bronze Housing Kit for DST100/DST110
33-398-04PW	Spare Paddle Wheel Kit

## SPECIFICATIONS

PARAMETER	VALUE	COMMENT
Depth Operating Frequency	235 kHz	Wide Beam Angle
Beam Width	10° x 44°	
Minimum Depth	0.4 meters	Deadrise Angle Tolerant
Maximum Depth	100 meters	No Calibration Required
Depth Accuracy	±20cm	0.6 – 7 meters
	±3%	7 – 100 meters
Depth Tracking Speeds	Up to 50 knots	High Speed Bottom Tracking Capability
Depth Update Rate	1 second	
Transmission Power	100 Watts	2% Duty Cycle
Speed Sensor	Paddlewheel	
Speed Range	1 – 50 knots	Microprocessor Signal Processing Accuracy
Speed Update Rate	1 second	
Water Temperature Range	-10°C to 40°C	Fast Response Time
Water Temperature Accuracy	±1.0°C	No Calibration Required
Water Temperature Resolution	0.01°C	
Deadrise Angle	≤22°	

## NMEA 2000® PARAMETER GROUP NUMBERS (PGNs)

DESCRIPTION	PGN#	PGN NAME	DEFAULT RATE
Periodic Data PGNs	128267	Water Depth	1 Time/Second
	128259	Speed (Water Referenced)	1 Time/Second
	130310	Environmental Parameters (Water Temperature)	2 Times/Second
	130311	Environmental Parameters (Water Temperature)	2 Times/Second
	130312	Temperature	0.5 Times/Second
	128275	Distance Log	1 Time/Second
Response to Requested PGNs	126464	PGN List (Transmit and Receive)	N/A
	126996	Product Information	N/A
	126998	Configuration Information	N/A
Protocol PGNs	059392	ISO Acknowledge	N/A
	059904	ISO Request	N/A
	060928	ISO Address Claim	N/A
	065240	ISO Address Command	N/A
	126208	NMEA Request/Command/Acknowledge	N/A

## ELECTRICAL

PARAMETER	VALUE	COMMENT
Operating Voltage	9 to 32 Volts	DC Voltage
Power Consumption	< 200mA	Average Current Drain
Load Equivalence Number (LEN)	4	NMEA 2000® Spec. (1LEN = 50mA)
Reverse Battery Protection	Yes	Indefinitely

## MECHANICAL

PARAMETER	VALUE	COMMENT
Size	2.94" Dia. x 4.87" Tall (74.7mm Dia. x 123.7mm Tall)	Including Flanges for Mounting
Weight	12 oz. (340 g)	
Mounting	Lexan/Bronze/Stainless Steel	Bronze/Stainless Steel Optional
Hole Diameter for Mounting	2" (51mm)	

## ENVIRONMENTAL

PARAMETER	VALUE
IEC 60945 Classification	Submerged
Degree of Protection	IP68
Operating Temperature	-10°C to 40°C
Storage Temperature	-30°C to 70°C
Vibration	2-13.2Hz @ ±1mm, 13.2-100Hz @ 7m/s² per IEC 60945-8.7
Water Immersion	per IEC 60945-8.9
Corrosion (Salt Mist)	4 times 7days @ 40°C, 95%RH after 2 hour Salt Spray Per IEC 60945-8.12
Electromagnetic Emission	Conducted and Radiated Emission per IEC 60945-9
Electromagnetic Immunity	Conducted, Radiated, Supply, and ESD per IEC 60945-10

## CERTIFICATIONS

PARAMETER	COMMENT
NMEA 2000® Standard	Level B+
Maritime Navigation and Radio Communication Equipment & Systems	EC 61162-3
Maritime Navigation and Radio Communication Equipment & Systems	IEC 60945
FCC and CE Mark	Electromagnetic Compatibility

# Cables and Connectors

## About NMEA 2000® Cables and Connectors

The NMEA 2000® standard goes beyond defining message content and includes requirements for the cabling used to interconnect electronic components (referred to as the physical interface). The following catalog pages contain the NMEA 2000® approved network interconnect components used to build an operational network.

## About Micro, Mid and Mini Cable Systems

There are three types of NMEA 2000® cabling systems, Micro, Mid and Mini. The Micro/Mid cable system is generally used for smaller networks requiring less power (i.e., less than 4 amps per network leg) while the Mini cable system is used for larger networks (i.e., more than 4 amps but less than 8 amps per leg).



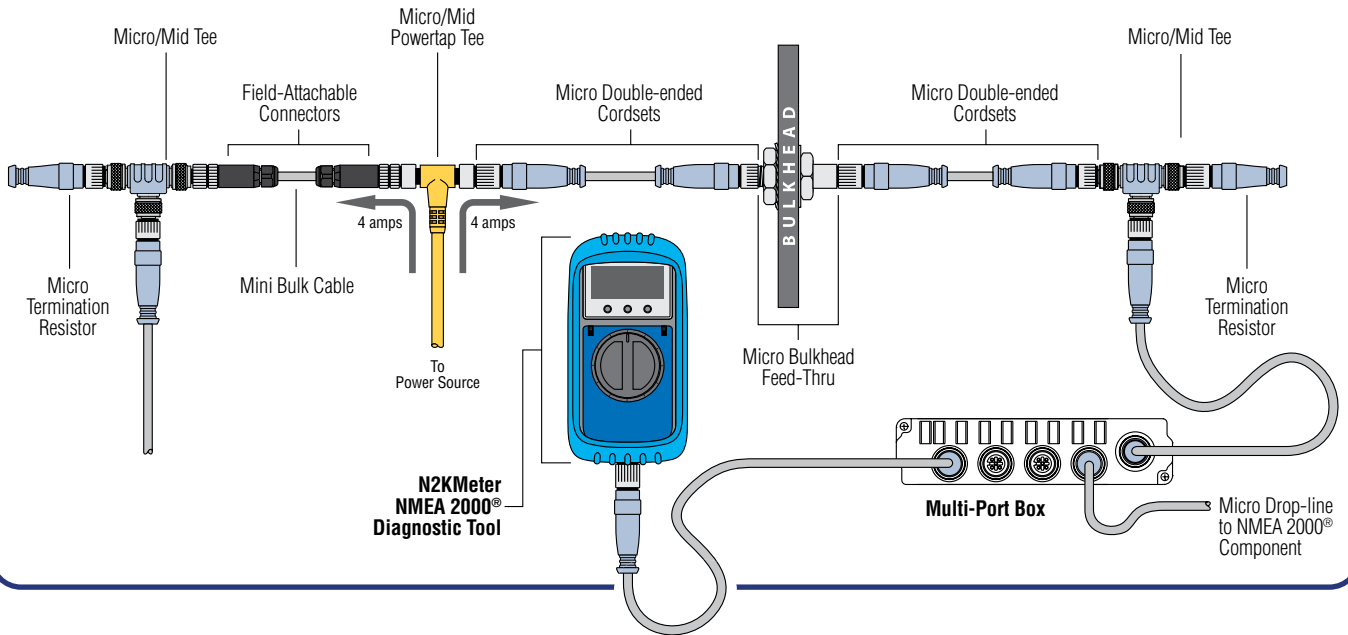
## NMEA 2000® Cable Features

- Simple trunk and drop line topology interconnects all NMEA 2000® equipment
- Drop line topology allows powered component removal or re-connection while rest of network remains operational
- Cable includes power and ground for powering equipment drawing less than 1 amp/device
- Connectors include keys and keyways for simple error-free connections
- Screw thread connectors reduce chances of accidental disconnects of essential equipment
- Waterproof connection system prevents corroded intermittent connections and continues to operate even while submerged in the bilge
- Three independent cable shields (power pair, signal pair, and overall cable) protects system from external noise sources such as high-power radio transmitters and radar units
- Nickel plated brass connector ends ideally suited to harsh marine environment
- Phosphor bronze contact base material with gold over nickel plate for reliable connections
- Overmolded cable connector ends provide strain relief
- Simple easy to use diagnostic components enable trained and untrained personnel to diagnose and troubleshoot network installations



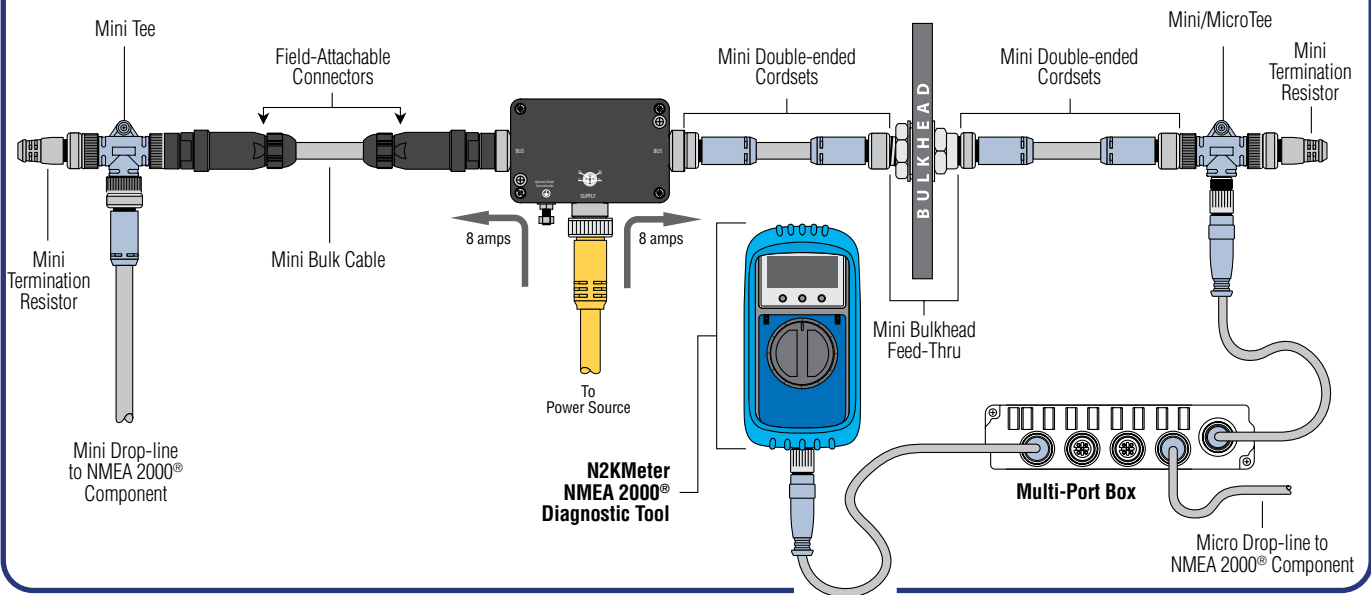
## Micro/Mid NMEA 2000® Network Example

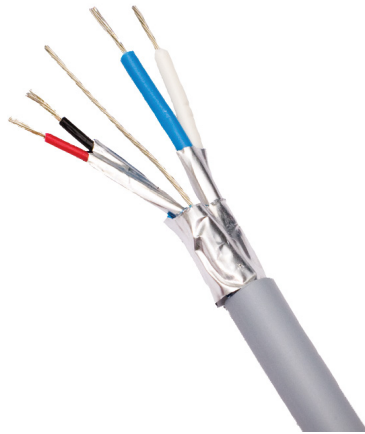
(Up to 4 amps per leg)



## Mini NMEA 2000® Network Example

(Up to 8 amps per leg)





## Micro Bulk Cable

Micro bulk cable is primarily used as drop cable, but it can also be used at the trunk line depending on network power requirements. Bulk cable with field-attachable connectors allows for maximum flexibility as cables can be made on the job to exact lengths.

- Meets and exceeds NMEA 2000® specifications for the highest reliability
- Trunk or drop cable for use with Micro connectors
- Used with field-attachable connectors to build exact length cables at the job site

### PRODUCTS

PART NUMBER	DESCRIPTION
CG1-10	Micro Bulk Cable - 10M (gray)
CG1-20	Micro Bulk Cable - 20M (gray)
CG1-30	Micro Bulk Cable - 30M (gray)
CG1-40	Micro Bulk Cable - 40M (gray)

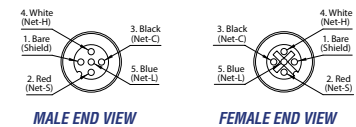
PART NUMBER	DESCRIPTION
CG1-50	Micro Bulk Cable - 50M (gray)
CG1-100C	Micro Bulk Cable - 100M w/spool (gray)
CG1-750C	Micro Bulk Cable - 750M w/spool (gray)



## Micro/Mid Field-Attachable Connectors (Straight Male/Female)

Field-attachable connectors allow you to make field connections to bulk cable (see diagram). The color-coded screw terminals match the individual wire colors found within the bulk cable for error-free field installation.

- Color-coded screw terminals make for error-free field installation
- Rugged housing material designed to withstand harsh marine environments



### PRODUCTS

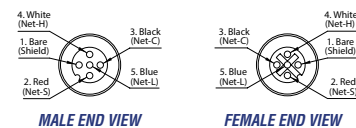
PART NUMBER	DESCRIPTION
FA-CF-ST	Micro/Mid Field Attachable Connector (Straight Female)
FA-CM-ST	Micro/Mid Field Attachable Connector (Straight Male)



## Micro/Mid Field-Attachable Connectors (90° Male/Female)

Like the straight Micro/Mid Field-attachable Connectors, the 90° field attachable connectors allow you to make field connections to bulk cable. The 90° connectors are particularly well suited for tight spaces like the back of displays where there is limited space for a straight connector.

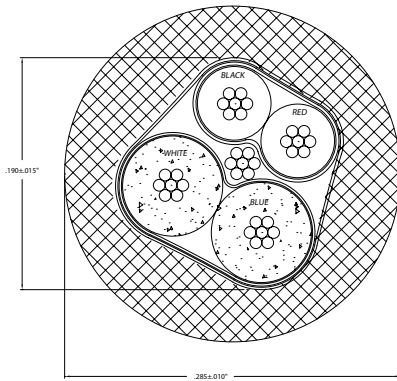
- Useful in tight spaces or where sharp corners need to be made
- Waterproof rated to IP67



### PRODUCTS

PART NUMBER	DESCRIPTION
FA-CF-90	Micro/Mid Field Attachable Connector (90° Female)
FA-CM-90	Micro/Mid Field Attachable Connector (90° Male)

## Specifications



### OVERALL

Outer Jacket Mat/Color	PVC/Gray
Insulation Material	PE (data wires), SRPVC (power wires)
Construction	4x22
Maximum Wire Size	16 (1.29mm) AWG
Cable Grip Range	6–8 mm

### ELECTRICAL

Wire	2 x 22 (0.65mm) AWG
Resistance/Conductor	18.1 Ohms/1000ft
Max Amperage	6 Amps
Color Code	Red/Black

### DATA PAIR

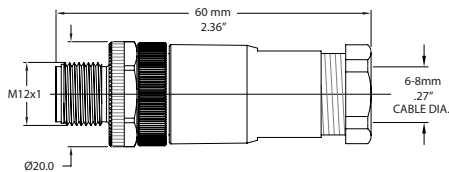
Wire	2x22 (0.65mm) AWG
Characteristic Impedance	120 Ohms ± 10%
Capacitance	11.33pF/FT ± 10%
Color Code	White/Blue

### APPROVALS

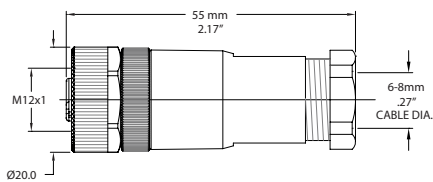
UL	PLTC 75°C Sunlight Resistant E90625, AWM 80°C 300V
CSA	CMX-OUTDOOR-CMG LL54185 75°C, AWM I/II A/B 80C 300V FT4
NMEA	NMEA 2000® Approved
IEC	IEC-61162-3

## Specifications

### MALE



### FEMALE



### MECHANICAL

Housing Mat/Plating	Nylon/Black
Contact Mat/Plating	Brass/Gold
Coupling Nut Mat/Plating	Brass/Nickel
Maximum Wire Size	16 (1.29mm) AWG
Cable Grip Range	6–8 mm

### ELECTRICAL

Rated Current	4.0 Amps
Rated Voltage	30 V AC/ 36 V DC

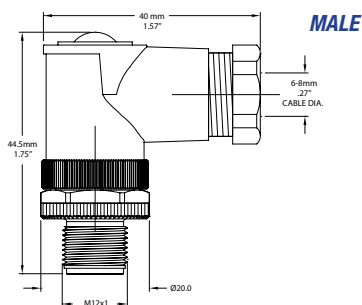
### ENVIRONMENTAL

Protection Class	IEC IP67
Temperature Range	-40°C to 85°C -40°F to 185°F

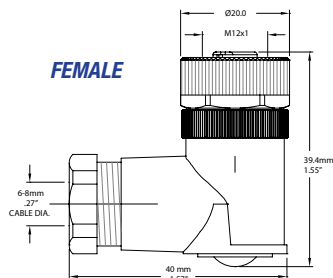
### APPROVAL

NMEA	NMEA 2000® Approved
IEC	IEC IP67

## Specifications



### FEMALE



### MECHANICAL

Housing Mat/Plating	Nylon/Black
Contact Mat/Plating	Brass/Optaloy
Coupling Nut Mat/Plating	Brass/Nickel
Maximum Wire Size	16 (1.29mm) AWG
Cable Grip Range	6–8 mm

### ELECTRICAL

Rated Current	4.0 Amps
Rated Voltage	30 V AC/ 36 V DC

### ENVIRONMENTAL

Protection Class	IEC IP67
Temperature Range	-40°C to 85°C -40°F to 185°F

### APPROVAL

NMEA	NMEA 2000® Approved
IEC	IEC-61162-3





## Micro Double-Ended Cordsets

Double-ended cordsets are used for trunk or drop lines and make for a secure connection and simple time-saving installation. The connectors are keyed for error-free connection and are waterproof for continued operation while submerged in the bilge.

- Rugged, IP68 rated connectors for continued connection integrity in marine environments
- Various cable lengths to match installation requirements

### PRODUCTS

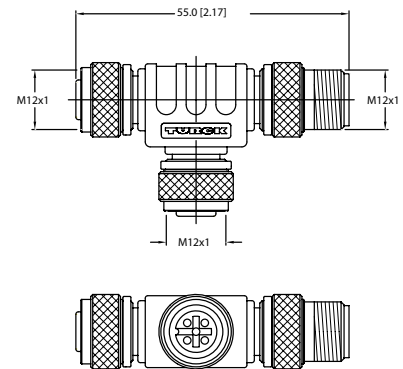
PART NUMBER	DESCRIPTION
CM-CG1-CF-00.5	Micro Double-Ended Cordset - M to F - 0.5M (gray)
CM-CG1-CF-01.0	Micro Double-Ended Cordset - M to F - 1M (gray)
CM-CG1-CF-02.0	Micro Double-Ended Cordset - M to F - 2M (gray)
CM-CG1-CF-03.0	Micro Double-Ended Cordset - M to F - 3M (gray)
CM-CG1-CF-04.0	Micro Double-Ended Cordset - M to F - 4M (gray)
CM-CG1-CF-05.0	Micro Double-Ended Cordset - M to F - 5M (gray)
CM-CG1-CF-06.0	Micro Double-Ended Cordset - M to F - 6M (gray)
CM-CG1-CF-08.0	Micro Double-Ended Cordset - M to F - 8M (gray)
CM-CG1-CF-10.0	Micro Double-Ended Cordset - M to F - 10M (gray)



## Micro Tee

A Tee is used to tap into the trunk line for adding a drop connection. The standard tee is also available with a cap for a protected diagnostic connection. Tees can be mated with all other devices on the network of the same connector style.

- Gold contacts for greatest reliability
- Keyed connectors for error-free connections



### PRODUCTS

PART NUMBER	DESCRIPTION
CM-CF-CF	Micro Tee



## Micro/Mid Powertap Tee

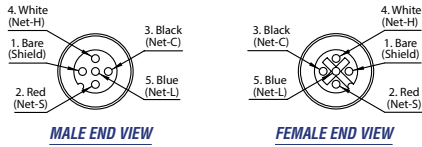
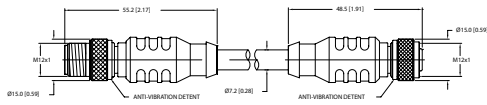
A Powertap Tee is connected to a network backbone just like any Tee but rather than connecting a device their purpose is to provide "bus" power. Maretron Powertap Tee uniquely provides two power inputs permitting doubled power provision for devices.

- Yellow cable indicates power and can't be confused with gray network cable
- Two cable lengths to match installation requirements

COLOR	NAME	USAGE	CONNECTOR
Blue	NET-C	Ground	J1
Brown	NET-S	Power	J1
Gray	SHIELD	Drain	J-1 & J-2
Black	NET-C	Ground	J2
White	NET-S	Power	J2

### PRODUCTS

PART NUMBER	DESCRIPTION
CF-SPWR05-CF	Micro/Mid Powertap Tee - FM (left)/ 5 Meter 5 Wire Power drop (bottom)/FM (right)



## Specifications

### MECHANICAL

Contact Carrier Mat/Color	Thermoplastic PUR/Blue-Gray
Molded Body Mat/Color	Thermoplastic PUR/Blue-Gray
Contact Mat/Plating	Brass/Gold
Coupling Nut Mat/Plating	Brass/Nickel
Cable Grip Range	0.59"

### ELECTRICAL

Current Rating	4.0 Amps
Voltage Rating	250 V

### ENVIRONMENTAL

Protection Class	IEC IP68, NEMA 1, 3, 4, 6P
Temperature Range	-40°C to 85°C -40°F to 185°F

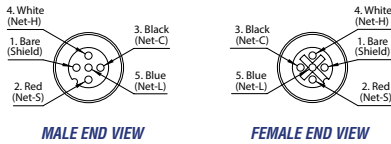
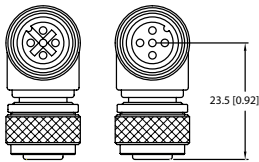
### CABLE

Outer Jacket Mat/Color	PVC/Gray
Conductor Insulation Material	HDPE (data pair), SRPVC (power pair)
Number of Conductors	4x22 AWG, 22 AWG Drain Wire
Shielding (3-Levels)	Foil (overall), Foil (power pair), Foil (data pair)

### APPROVALS

Cable UL	PLTC 75°C Sunlight Resistant E90625, AWM 80°C 300V
CSA	CMX-OUTDOOR-CMG LL54185 75°C, AWM I/II A/B 80C 300V FT4
NMEA	NMEA 2000® Approved
IEC	IEC-61162-3

## Specifications



### MECHANICAL

Molded Body Mat/Color	Thermoplastic PUR/Blue
Contact Carrier Mat Color	PA 6 (Nylon)/Black
Contact Mat/Plating	Brass/Gold
Coupling Nut Mat/Plating	Brass/Nickel

### ELECTRICAL

Rated Current	4.0 Amps
Rated Voltage	60 V

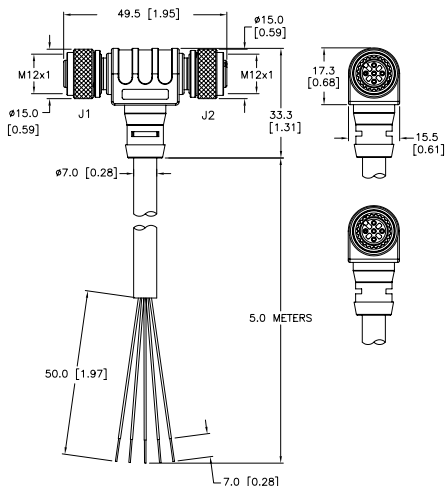
### ENVIRONMENTAL

Protection Class	IEC IP68, NEMA 1, 3, 4, 6P
Temperature Range	-40°C to 85°C -40°F to 185°F

### APPROVAL

NMEA	NMEA 2000® Approved
IEC	IEC IP67

## Specifications



### MECHANICAL

Molded Body Mat/Color	Thermoplastic PUR/Yellow
Contact Carrier Mat/Color	PA 6 (Nylon)/Black
Contact Mat/Plating	Brass/Gold
Coupling Nut Mat/Plating	Brass/Nickel
Cable Jacket Mat/Color	PVC/Yellow
Conductor Insulation Mat	PVC
Number of Conductors	5x18 (1.02mm) AWG

### ELECTRICAL

Voltage Rating	250 V
Max Amperage	4.0 Amps

### ENVIRONMENTAL

Protection Class	IEC IP67, NEMA 1, 3, 4, 6P
Temperature Range	-40°C to 105°C -40°F to 221°F

### APPROVAL

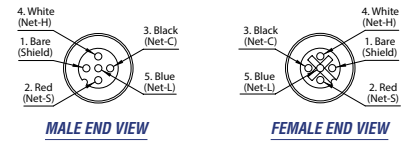
NMEA	NMEA 2000® Approved
IEC	IEC-61162-3



## Micro Termination Resistors

Two termination resistors are required on every NMEA 2000® network, one on each end of the trunk line. Normally, a male termination is used since male pins tend to point back to the power source. In cases where the gender is reversed, a female terminator may be required. The inline terminator is used where the network is terminated at a product, for example a GPS or weather station at the top of a mast.

- Screw terminal connector for positive connections
- Termination resistors are used to terminate both ends of the trunk line



### PRODUCTS

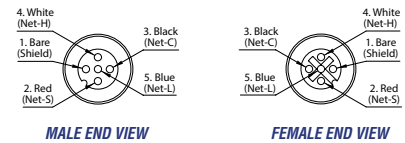
PART NUMBER	DESCRIPTION
TR-CM	Micro Termination Resistor (Male)
TR-CF	Micro Termination Resistor (Female)
IT-CM-CF	Micro Inline Terminator



## Micro Bulkhead Feed-Thru

The Bulkhead Feed-Thru allows ease of installation through panels or bulkheads and establishes future connection points in a network installation. The Bulkhead Feed-Thru also maintains the integrity of watertight bulkheads by providing a waterproof seal and connection.

- Features rugged keyways for positive alignment of connections
- Waterproof rated to IP67



### PRODUCTS

PART NUMBER	DESCRIPTION
BHF-CM-CF	Micro Bulkhead Feed-Thru



## Multiport Box (Micro/Mid Male Homerun/ Micro-Mid Female Drops)

Multiport boxes allow several drop cables to be consolidated and connected back to the trunk, which eliminates the need to have numerous tees connected near a single point. Multiport boxes connect back to the trunk through a double-ended cordset and Tee.

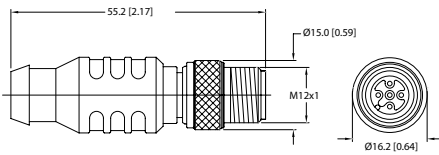
- Ideal for consolidating many connections; for example behind dashboards
- Requires the purchase of an additional double-ended cordset for connection back to the trunk

### PRODUCTS

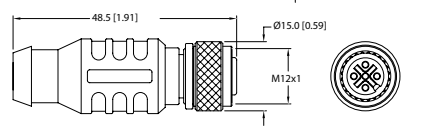
PART NUMBER	DESCRIPTION
CM-CF-4	Multiport Box (Micro-Mid Male Homerun / Micro-Mid Female Drops)



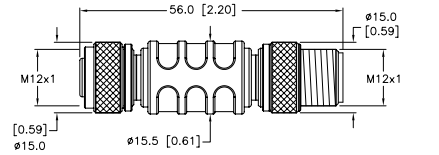
### MALE



### FEMALE



### INLINE



## Specifications

### MECHANICAL

Molded Body Mat/Color	Thermoplastic PUR/Blue-Gray TR-CM, TR-CF
Contact Carrier Mat/Color	Thermoplastic PUR/Blue-Gray TR-CM, TR-CF
Contact Mat/Plating	Thermoplastic PUR/Black IT-CM-CF
Coupling Nut Mat/Plating	Brass/Gold
	Brass/Nickel

### ELECTRICAL

Rated Voltage	10-30 V DC
Voltage Rating	250 V
	120 Ohms (1/2 W) – TR-CM, TR-CF
	121 Ohms (1/2 W) - IT-CM-CF

### ENVIRONMENTAL

Protection Class	IEC IP68, NEMA 1, 3, 4, 6P
------------------	----------------------------

### APPROVALS

NMEA	NMEA 2000® Approved
IEC	IEC-61162-3

## Specifications

### MECHANICAL

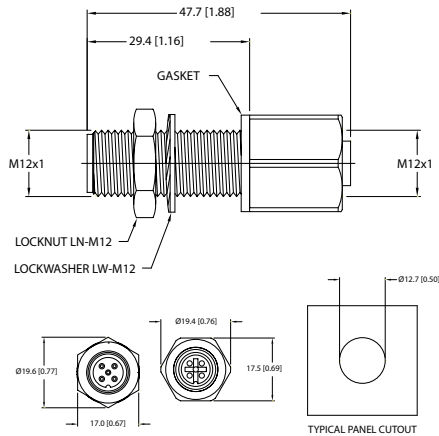
Contact Carrier Mat Color	PA 6 (Nylon)/Blue-Gray
Contact Mat/Plating	Brass/Gold
Housing Mat/Plating	Brass Nickel
Gasket Material	Nitrile (Buna N)
Accommodates Wall (thick)	.40" (1.0mm) to .875" (22.2mm)

### ENVIRONMENTAL

Protection Class	IEC IP67, NEMA 1, 3, 4, 6P
Temperature Range	-40°C to 105°C -40°F to 221°F

### APPROVAL

NMEA	NMEA 2000® Approved
IEC	IEC 61162-3



## Specifications

### MECHANICAL

Housing Mat/Color	Nylon/Blue-Gray
Receptacle Mat/Plating	Brass/Nickel
Contact Carrier Mat/Color	Nylon/Black
Contact Mat/Plating	Brass/Gold

### ENVIRONMENTAL

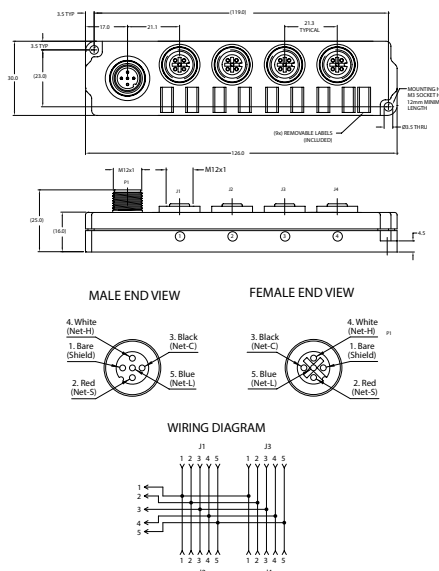
Protection Class	IEC IP67 – when receptacles are covered
Temperature Range	-30°C to 80°C -22°F to 176°F

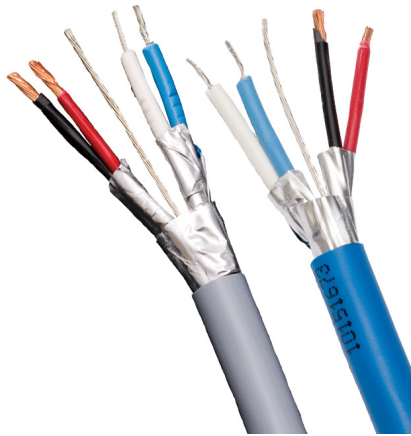
### ELECTRICAL

Operating Voltage	250 V
Operating Current	4.0 Amps

### APPROVAL

NMEA	NMEA 2000® Approved
IEC	IEC-61162-3





## Mid Bulk Cable (Gray/Blue)

Mid bulk cable is primarily used as drop cable, but it can also be used at the trunk line depending on network power requirements. Bulk cable with field-attachable connectors allows for maximum flexibility as cables can be made on the job to exact lengths.

Meets and exceeds NMEA 2000® specifications for the highest reliability

Used with field-attachable connectors to build exact length cables at the job site

Optimized for voltage drop sensitive networks (long runs) because power pair wires have half the resistance of Micro cable

### PRODUCTS

PART NUMBER	DESCRIPTION
DG1-10	Mid Bulk Cable - 10M (gray)
DG1-20	Mid Bulk Cable - 20M (gray)
DG1-30	Mid Bulk Cable - 30M (gray)
DG1-40	Mid Bulk Cable - 40M (gray)
DG1-50	Mid Bulk Cable - 50M (gray)
DG1-100C	Mid Bulk Cable - 100M w/spool (gray)
DG1-600C	Mid Bulk Cable - 600M w/spool (gray)

PART NUMBER	DESCRIPTION
DB1-10	Mid Bulk Cable - 10M (blue)
DB1-20	Mid Bulk Cable - 20M (blue)
DB1-30	Mid Bulk Cable - 30M (blue)
DB1-40	Mid Bulk Cable - 40M (blue)
DB1-50	Mid Bulk Cable - 50M (blue)
DB1-100C	Mid Bulk Cable - 100M w/spool (blue)
DB1-600C	Mid Bulk Cable - 600M w/spool (blue)

## Mid Double-Ended Cordsets

Double-ended cordsets are used for trunk or drop lines and make for a secure connection and simple time-saving installation. The connectors are keyed for error-free connection and are waterproof for continued operation even while submerged in the bilge.

- Rugged, IP68 rated connectors for continued connection integrity in marine environments
- Various cable lengths to match installation requirements
- Optimized for voltage drop sensitive networks (long runs) because power pair wires have half the resistance of Micro cable



GRAY

### Mid Double-Ended Cordsets (Gray)

#### PRODUCTS

PART NUMBER	DESCRIPTION
DM-DG1-DF-00.5	Mid Double-Ended Cordset - M to F - 0.5M (gray)
DM-DG1-DF-01.0	Mid Double-Ended Cordset - M to F - 1M (gray)
DM-DG1-DF-02.0	Mid Double-Ended Cordset - M to F - 2M (gray)
DM-DG1-DF-03.0	Mid Double-Ended Cordset - M to F - 3M (gray)
DM-DG1-DF-04.0	Mid Double-Ended Cordset - M to F - 4M (gray)
DM-DG1-DF-05.0	Mid Double-Ended Cordset - M to F - 5M (gray)
DM-DG1-DF-06.0	Mid Double-Ended Cordset - M to F - 6M (gray)
DM-DG1-DF-08.0	Mid Double-Ended Cordset - M to F - 8M (gray)
DM-DG1-DF-10.0	Mid Double-Ended Cordset - M to F - 10M (gray)



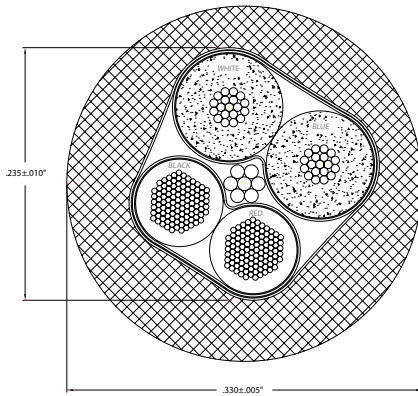
BLUE

### Mid Double-Ended Cordsets (Blue)

#### PRODUCTS

PART NUMBER	DESCRIPTION
DM-DB1-DF-00.5	Mid Double-Ended Cordset - M to F - 0.5M (blue)
DM-DB1-DF-01.0	Mid Double-Ended Cordset - M to F - 1M (blue)
DM-DB1-DF-02.0	Mid Double-Ended Cordset - M to F - 2M (blue)
DM-DB1-DF-03.0	Mid Double-Ended Cordset - M to F - 3M (blue)
DM-DB1-DF-04.0	Mid Double-Ended Cordset - M to F - 4M (blue)
DM-DB1-DF-05.0	Mid Double-Ended Cordset - M to F - 5M (blue)
DM-DB1-DF-06.0	Mid Double-Ended Cordset - M to F - 6M (blue)
DM-DB1-DF-08.0	Mid Double-Ended Cordset - M to F - 8M (blue)
DM-DB1-DF-10.0	Mid Double-Ended Cordset - M to F - 10M (blue)

## Specifications



### OVERALL

Outer Jacket Mat/Color	PVC/Gray - DG1 PVC/ Blue - DB1
Insulation Material	PE (data wires), PVC (power wires)
Construction	2x16 (1.29mm) AWG, 2x20 (0.81mm) AWG, 20 (0.81mm) AWG Drain Wire
Shielding (3 levels)	Foil (overall), Foil (power pair), Foil (data pair)

### POWER PAIR

Wire	2x16 (1.29mm) AWG
Resistance/Conductor	4.1 Ohms/1000 ft max
Max Amperage	14 Amps
Color Code	Red/Black

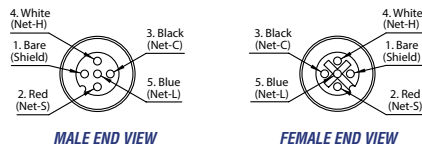
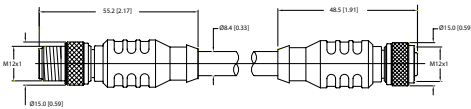
### DATA PAIR

Wire	2x20 (0.81mm) AWG
Characteristic Impedance	120 Ohms ±10%
Capacitance	10.75 pF/ft
Color Code	White/Blue

### APPROVALS

UL	PLTC 75°C Sunlight Resistant E90625, AWM 80°C 300V
CSA	CMX-OUTDOOR-CMG LL54185 75°C, AWM I/II A/B 80C 300V FT4
NMEA	NMEA 2000® Approved
IEC	IEC-61162-3

## Specifications



### MECHANICAL

Contact Carrier Mat/Color	Thermoplastic PUR/ Blue-Gray
Molded Body Mat/Color	Thermoplastic PUR/ Blue-Gray
Contact Mat/Plating	Brass/Gold
Coupling Nut Mat/Plating	Brass/Nickel
Connector Outside Diameter	0.59"

### ELECTRICAL

Current Rating	4.0 Amps
Voltage Rating	250 V

### CABLE

Outer Jacket Mat/Color	PVC/Gray - DG1 PVC/ Blue - DB1
Insulation Material	PE (data wires), PVC (power wires)
Construction	2x16 (1.29mm) AWG, 2x20 (0.81mm) AWG, 20 (0.81mm) AWG Drain Wire
Shielding (3 levels)	Foil (overall), Foil (power pair), Foil (data pair)

### ENVIRONMENTAL

Protection Class	IEC IP68, NEMA 1, 3, 4, 6P
Temperature Rating	-40°C to 80°C -40°F to 176°F

### APPROVALS

(Cable) UL	PLTC 75°C Sunlight Resistant E90625, AWM 80°C 300V
(Cable) CSA	CMX-OUTDOOR-CMG LL54185 75°C, AWM I/II A/B 80C 300V FT4
NMEA	NMEA 2000® Approved
IEC	IEC-61162-3

## Nylon to Metal Connector Cable



Some products use inexpensive nylon connectors and when connected with metal connectors, the nylon threads can be damaged. This cable eliminates the problem by allowing nylon to nylon connections and metal to metal connections.

- NMEA 2000® Approved
- Waterproof rated to IP67

### PRODUCTS

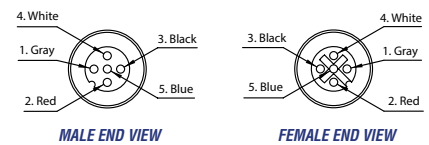
PART NUMBER	DESCRIPTION
QCM-CG1-QCF-01	Nylon to Metal Connector Cable

## Micro 90° Male to Female Connector



A 90 degree male to female connector for Micro or Mid size cable runs or connections which is intended to aid turning tight radiuses without unduly straining the wires within a cable. Ideal when mounting a device in a location with shallow depth possibilities.

- NMEA 2000® Approved
- Waterproof rated to IP67



### PRODUCTS

PART NUMBER	DESCRIPTION
ELB-CM-CF	Micro 90° Male to Female Connector

## Mid Single-Ended Cordset Female to Open Pigtail (25 Meter Blue)



This 25 meter length Mid size cable with a Micro female connector on one end is intended for installation of devices such as a weather station. The female connector should point towards the device and a field attachable male connector should be made onto the end connecting to the rest of the backbone.

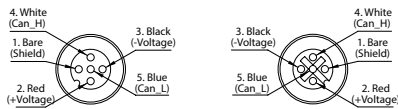
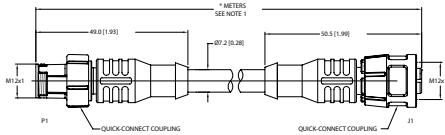
- NMEA 2000® Approved
- Meets ABYC Power Pair size requirements
- Waterproof rated to IP67

### PRODUCT

PART NUMBER	DESCRIPTION
DF-DB1-25.0	Mid Single-Ended Cordset — Female to Open Pigtail – 25 Meter (blue)



## Specifications



MALE END VIEW

### MECHANICAL

Molded Head Mat/Color	Thermoplastic PUR/Blue-Gray
Contact Carrier Mat/Color	Thermoplastic PUR/Black
Contact Mat/Plating	Brass/Gold
Snap-Lock Mat/Color	POM/Black

### ELECTRICAL

Rated Current	4.0 Amps
Rated Voltage	250 V

### ENVIRONMENTAL

Protection Class	IEC IP67
Temperature Range	-40°C to 80°C -40°F to 176°F

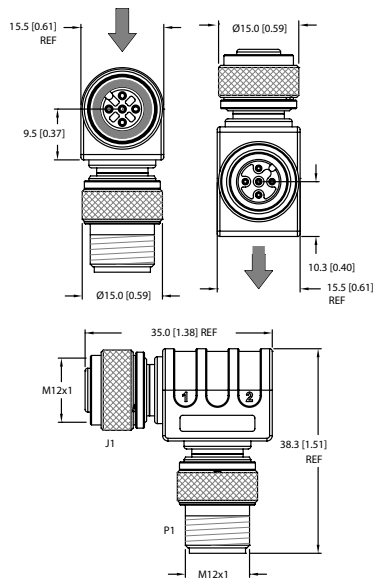
### CABLE

Outer Jacket Mat/Color	PVC/Gray
Conductor Insulation Mat	HDPE (data wires), SRPVC (power wires)
Construction	4x32 (0.65 mm) AWG, 22 (0.65mm) AWG Drain Wire
Shielding (3 levels)	Foil (overall), Foil (power pair), Foil (data pair)

### APPROVALS

NMEA	NMEA 2000® Approved
IEC	IEC-61162-3

## Specifications



### MECHANICAL

Molded Body Mat/Color	Thermoplastic PUR/Gray
Contact Carrier Mat/Color	Nylon PUR
Contact Mat/Plating	Brass/Gold
Coupling Nut Mat/Plating	Brass/Nickel

### ELECTRICAL

Rated Current	4.0 Amps
Rated Voltage	50 V

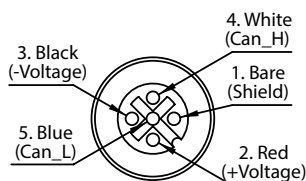
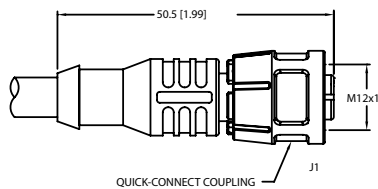
### ENVIRONMENTAL

Protection Class	IEC IP67, NEMA 1, 3, 4, 6P
Temperature Range	-40°C to 105°C -40°F to 221°F

### APPROVAL

NMEA	NMEA 2000® Approved
IEC	IEC 61162-3

## Specifications



FEMALE END VIEW

### MECHANICAL

Molded Head Mat/Color	Thermoplastic PUR/Blue-Gray
Contact Carrier Mat/Color	Thermoplastic PUR/Blue-Gray
Contact Mat/Plating	Brass/Gold
Coupling Nut Mat/Color	Brass/Nickel
Connector Outside Diameter	0.59"

### ELECTRICAL

Rated Current	4.0 Amps
Rated Voltage	250 V

### ENVIRONMENTAL

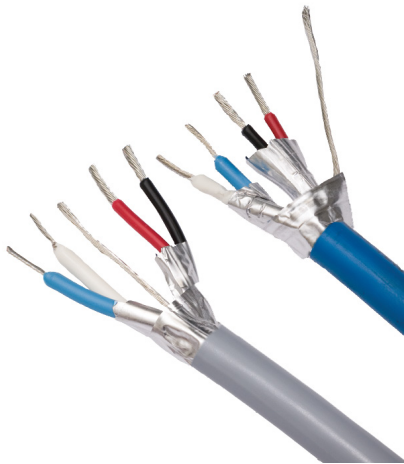
Protection Class	IEC IP68, NEMA 1, 3, 4, 6P
Temperature Range	-40°C to 80°C -40°F to 176°F

### CABLE

Outer Jacket Mat/Color	PVC/Blue
Conductor Insulation Mat	PE (data wires), PVC (power wires)
Number of Conductors	2x16 (1.29mm) AWG, 2x20 (0.81mm) AWG, 20 (0.81mm) AWG Drain Wire
Shielding (3 levels)	Foil (overall), Foil (power pair), Foil (data pair)

### APPROVALS

Cable UL	PLTC 75°C Sunlight Resistant E90625, AWM 80°C 300V
CSA	CMX-OUTDOOR-CMG LL54185 75°C, AWM I/II A/B 80C 300V FT4
NMEA	NMEA 2000® Approved
IEC	IEC-61162-3



## Mini Bulk Cable (Gray/Blue)

Mini bulk cable is primarily used as trunk cable, but it can also be used as drop lines. Bulk cable with field-attachable connectors allows for maximum flexibility as cables can be made on the job to exact lengths.

- Meets and exceeds NMEA 2000® specifications for the highest reliability
- Trunk or drop cable for use with Mini connectors
- Used with field-attachable connectors to build exact length cables at the job site

### PRODUCTS

PART NUMBER	DESCRIPTION
NG1-10	Mini Bulk Cable - 10M (gray)
NG1-20	Mini Bulk Cable - 20M (gray)
NG1-30	Mini Bulk Cable - 30M (gray)
NG1-40	Mini Bulk Cable - 40M (gray)
NG1-50	Mini Bulk Cable - 50M (gray)
NG1-100C	Mini Bulk Cable - 100M w/spool (gray)
NG1-750	Mini Bulk Cable (non-continuous) - 750M w/spool (gray)

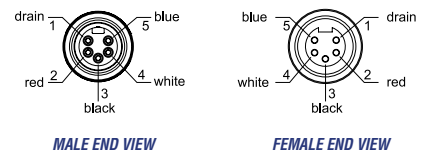
PART NUMBER	DESCRIPTION
NB1-10	Mini Bulk Cable - 10M (blue)
NB1-20	Mini Bulk Cable - 20M (blue)
NB1-30	Mini Bulk Cable - 30M (blue)
NB1-40	Mini Bulk Cable - 40M (blue)
NG1-50	Mini Bulk Cable - 50M (blue)
NB1-100C	Mini Bulk Cable - 100M w/spool (blue)
NB1-750	Mini Bulk Cable (non-continuous) - 750M w/spool (blue)



## Mini Field-Attachable Connector (Male/Female)

Field-attachable connectors allow you to make field connections to bulk cable. The color-coded screw terminals match the individual wire colors found within the bulk cables for error-free field installation.

- Color-coded screw terminators make for error-free field installation
- Rugged housing material designed to withstand harsh marine environments



### PRODUCTS

PART NUMBER	DESCRIPTION
FA-NF-ST	Mini Field Attachable Connector (Female)
FA-NM-ST	Mini Field Attachable Connector (Male)



## Mini Double-Ended Cordset (Gray)

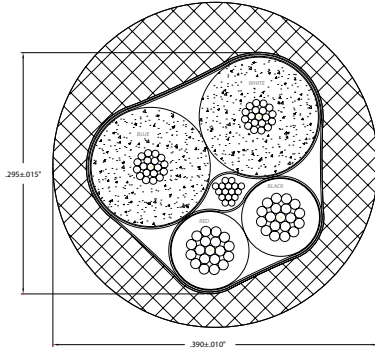
Double-ended cordsets are used for trunk or drop lines and make for a secure connection and simple time-saving installation. The connectors are keyed for error-free connection and are waterproof for continued operation even while submerged in the bilge.

- Rugged, IP68 rated connectors for continued connection integrity in marine environment
- Various cable lengths to match installation requirements

### PRODUCTS

PART NUMBER	DESCRIPTION
NM-NG1-NF-00.5	Mini Double-Ended Cordset - M to F - 0.5M (gray)
NM-NG1-NF-01.0	Mini Double-Ended Cordset - M to F - 1M (gray)
NM-NG1-NF-02.0	Mini Double-Ended Cordset - M to F - 2M (gray)
NM-NG1-NF-03.0	Mini Double-Ended Cordset - M to F - 3M (gray)
NM-NG1-NF-04.0	Mini Double-Ended Cordset - M to F - 4M (gray)
NM-NG1-NF-05.0	Mini Double-Ended Cordset - M to F - 5M (gray)
NM-NG1-NF-06.0	Mini Double-Ended Cordset - M to F - 6M (gray)
NM-NG1-NF-08.0	Mini Double-Ended Cordset - M to F - 8M (gray)
NM-NG1-NF-10.0	Mini Double-Ended Cordset - M to F - 10M (gray)

## Specifications



### OVERALL

Outer Jacket Mat/Color	PVC/Blue – NB1 PVC/Gray – NG1
Insulation Material	PE (data), PVC (power)
Construction	2x15 (1.45 mm) AWG, 2x18 (1.02mm) AWG 18 (1.02mm) AWG Drain Wire
Shielding (3 levels)	Foil (overall), Foil (power pair), Foil (data pair)

### POWER PAIR

Wire	2x15 (1.45mm) AWG
Resistance/Conductor	3.44 Ohms/1000 ft max
Max Amperage	16 Amps – NB1 14 Amps – NG1
Color Code	Red/Black

### DATA PAIR

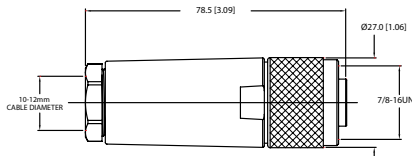
Wire	2x18 (1.02mm) AWG
Characteristic Impedance	120 Ohms ± 10%
Capacitance	12 pF/1000 ft max
Color Code	White/Blue

### APPROVALS

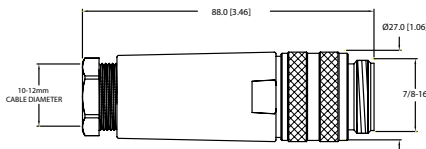
Cable UL	PLTC 75°C Sunlight Resistant E90625, AWM 80°C 300V
CSA	CMX-OUTDOOR-CMG LL54185 75°C, AWM I/II A/B 80C 300V FT4
NMEA	NMEA 2000® Approved
IEC	IEC-61162-3

## Specifications

### FEMALE



### MALE



### MECHANICAL

Housing Mat/Color	Glass Filled Nylon/Black
Contact Mat/Color	Brass/Gold
Coupling Nut Material	Anodized Aluminum
Maximum Wire Size	14 (1.63mm) AWG
Termination Method	Screw Terminal

### ELECTRICAL

Rated Current	9.0 Amps
Rated Voltage	250 V

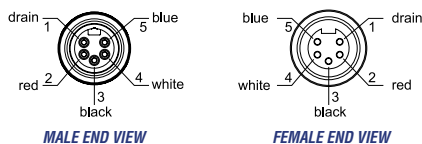
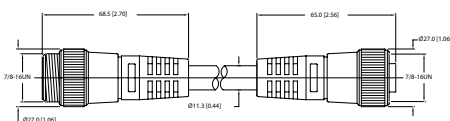
### ENVIRONMENTAL

Protection Class	IEC IP67
Temperature Range	-40°C to 85°C -40°F to 185°F

### APPROVAL

NMEA	NMEA 2000® Approved
IEC	IEC 61162-3

## Specifications



### MECHANICAL

Molded Head Mat/Color	Thermoplastic PUR/ Blue-Gray
Contact Carrier Mat/Color	Thermoplastic PUR/ Blue-Gray
Contact Mat/Plating	Brass/Gold
Coupling Nut Mat/Color	Brass/Nickel
Connector Outside Diameter	1.06"

### ELECTRICAL

Rated Current	9.0 Amps
Rated Voltage	300 V

### ENVIRONMENTAL

Protection Class	IEC IP68, NEMA 1, 3, 4, 6P
Temperature Range	-40°C to 80°C -40°F to 176°F

### CABLE

Outer Jacket Mat/Color	PVC/Gray
Conductor Insulation Materials	PE (data pair), PVC (power wires)
Number of Conductors	2x15 (1.45mm) AWG, 2x18 (1.02mm) AWG, 18 (1.02mm) AWG Drain Wire
Shielding (3 levels)	Braid (overall), Foil (power pair), Foil (data pair)

### APPROVALS

(Cable) UL	PLTC 75°C Sunlight Resistant E90625, AWM 80°C 300V
(Cable) CSA	CMX-OUTDOOR-CMG LL54185 75°C, AWM I/II A/B 80C 300V FT4
NMEA	NMEA 2000® Approved
IEC	IEC-61162-3

## Mini Double-Ended Cordset (Blue)



Double-ended cordsets are used for trunk or drop lines and make for a secure connection and simple time-saving installation. The connectors are keyed for error-free connection and are waterproof for continued operation even while submerged in the bilge.

- Rugged, IP67 rated connectors for continued connection integrity in marine environment
- Various cable lengths to match installation requirements

### PRODUCTS

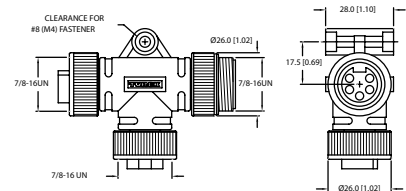
PART NUMBER	DESCRIPTION
NM-NB1-NF-00.5	Mini Double-Ended Cordset - M to F - 0.5M (blue)
NM-NB1-NF-01.0	Mini Double-Ended Cordset - M to F - 1M (blue)
NM-NB1-NF-02.0	Mini Double-Ended Cordset - M to F - 2M (blue)
NM-NB1-NF-03.0	Mini Double-Ended Cordset - M to F - 3M (blue)
NM-NB1-NF-04.0	Mini Double-Ended Cordset - M to F - 4M (blue)
NM-NB1-NF-05.0	Mini Double-Ended Cordset - M to F - 5M (blue)
NM-NB1-NF-06.0	Mini Double-Ended Cordset - M to F - 6M (blue)
NM-NB1-NF-08.0	Mini Double-Ended Cordset - M to F - 8M (blue)
NM-NB1-NF-10.0	Mini Double-Ended Cordset - M to F - 10M (blue)



## Mini Tees

A Tee is used to tap into the trunk line for adding a drop connection. Two Mini Tees are available: 1) a Mini Tee with Mini connectors for the trunk and drop lines, and 2) a Mini/Micro Tee with Mini connectors for the trunk lines and a Micro connector for the drop line.

- Gold Contacts for greatest reliability
- Keyed connectors for error-free connections



### PRODUCTS

PART NUMBER	DESCRIPTION
NM-NF-NF	Mini Tee
NM-CF-NF	Mini/Micro Tee

## Mini 90° Male to Female Connector



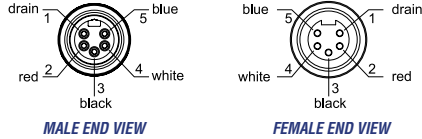
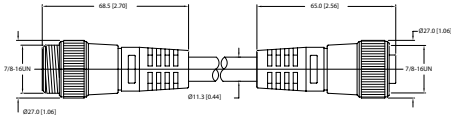
The Mini Elbow is used in spots where it is impossible to bend a cordset around tight corners. The elbow easily connects to a tee or double-ended cordsets making 90 [degree] turns practical at the end or anywhere along the line.

- Mounting hole for secure fastening of cabling system
- Waterproof seals for reliable connections
- Nickel plated brass ideally suited for harsh marine environment

### PRODUCTS

PART NUMBER	DESCRIPTION
ELB-NM-NF	Mini 90° Male to Female Connector





## Specifications

### MECHANICAL

Molded Head Mat/Color	Thermoplastic PUR/ Blue-Gray
Contact Carrier Mat/Color	Thermoplastic PUR/ Blue-Gray
Contact Mat/Plating	Brass/Gold
Coupling Nut Mat/Color	Brass/Nickel
Connector Outside Diameter	1.06"

### ELECTRICAL

Rated Current	9.0 Amps
Rated Voltage	300 V

### ENVIRONMENTAL

Protection Class	IEC IP67, NEMA 1, 3, 4, 6P
Temperature Range	-40°C to 80°C -40°F to 176°F

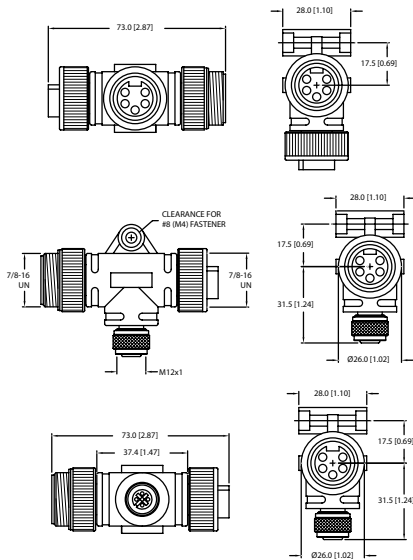
### CABLE

Outer Jacket Mat/Color	PVC/Gray
Conductor Insulation Materials	PE (data pair), PVC (power wires)
Number of Conductors	2x15 (1.45mm) AWG, 2x18 (1.02mm) AWG, 18 (1.02mm) AWG Drain Wire
Shielding (3 levels)	Braid (overall), Foil (power pair), Foil (data pair)

### APPROVALS

(Cable) UL	PLTC 75°C Sunlight Resistant E90625, AWM 80°C 300V
(Cable) CSA	CMX-OUTDOOR-CMG LL54185 75°C, AWM I/II A/B 80C 300V FT4
NMEA	NMEA 2000® Approved
IEC	IEC-61162-3

## Specifications



### MECHANICAL

Molded Head Mat/Color	Thermoplastic PUR/ Blue-Gray
Contact Carrier Mat/Color	Thermoplastic PUR/ Blue-Gray
Contact Mat/Plating	Brass/Gold
Coupling Nut Mat/Color	Brass/Nickel

### ELECTRICAL

Rated Current	9.0 Amps – NM-NF-NF 4.0 Amps (Micro) 9.0 Amps – NM-CF-NF
Rated Voltage	600 V – NM-NF-NF 250 V – NM-CF-NF

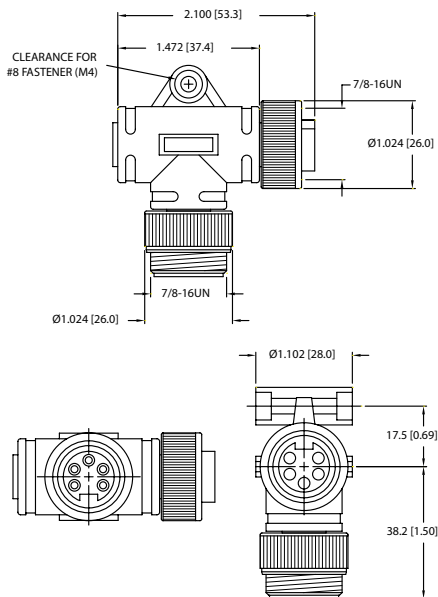
### ENVIRONMENTAL

Protection Class	IEC IP67, NEMA 1, 3, 4, 6P
Temperature Range	-40°C to 80°C -40°F to 176°F

### APPROVAL

NMEA	NMEA 2000® Approved
IEC	IEC 61162-3

## Specifications



### MECHANICAL

Molded Head Mat/Color	Thermoplastic PUR/Blue
Contact Carrier Mat/Color	Thermoplastic PUR/Blue
Contact Mat/Plating	Brass/Gold
Coupling Nut Mat/Color	Brass/Nickel

### ELECTRICAL

Rated Current	9.0 Amps
Rated Voltage	600 V

### ENVIRONMENTAL

Protection Class	IEC IP67, NEMA 1, 3, 4, 6P
Temperature Range	-40°C to 80°C -40°F to 176°F

### APPROVALS

NMEA	NMEA 2000® Approved
IEC	IEC-61162-3



## Mini Powertap/Mini Power Cord

A Powertap is connected to a network backbone just like any Tee but rather than connecting a device, its purpose is to provide "bus" power. Typically a Powertap is placed as central as possible between total devices on backbone. Maretron Powertap uniquely provides two power inputs permitting doubled power provision for devices.

- Connects power supply to NMEA 2000® Trunk Line in convenient plug/play fashion
- Replaceable fuses to protect bus and connected components from excessive current

COLOR	NAME	USAGE	CONNECTOR
Black	NET-C	Ground	V-1 & V-2
White	NET-S	Power	V+1 & V+2
Green	NET-C	Ground	V-1 & V-2
Red	NET-S	Power	V+1 & V+2

### PRODUCTS

PART NUMBER	DESCRIPTION
NF-NM4P-NF	Mini Powertap - Female-Female with Fuses
NM4P-01	Mini Power Cord - Female to Pigtail - 1 Meter
NM4P-05	Mini Power Cord - Female to Pigtail - 5 Meter



## Mini Termination Resistor (Male/Female)

Termination Resistors are required on a NMEA 2000® network and are placed at each end of a network trunk cable. Like the double-ended cordsets, the termination resistors are waterproof and continue to function even while submerged in the bilge.

- Diagnostic versions indicate correct polarity at a glance to ensure power connections have been made properly
- Screw connector for positive connection
- Termination resistors are used to terminate both ends of the trunk line

### PRODUCTS

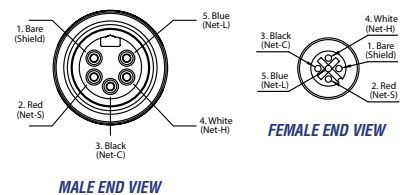
PART NUMBER	DESCRIPTION
TR-NM	Mini Termination Resistor (Male)
TR-NF	Mini Termination Resistor (Female)
TRL-NM	Mini Termination Resistor with LED (Male)
TRL-NF	Mini Termination Resistor with LED (Female)



## Mini Male to Micro Female Reducer

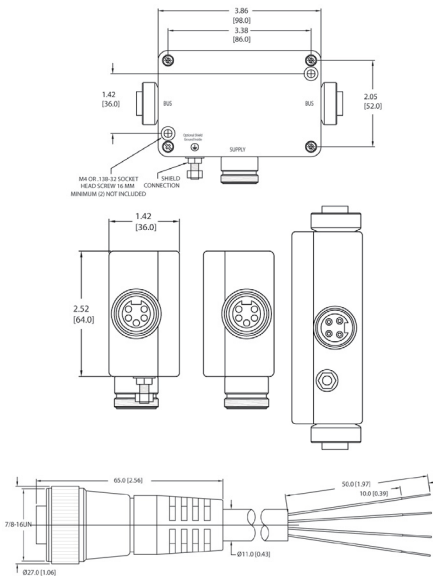
The reducer is used to change from a Mini cable to Micro or Mid cable. For example, one end of the network might be terminated at the top of the mast but it may not be desirable to run a Mini trunk cable up the mast. In this case, you can switch over to Micro or Mid cable at the base of the mast using the reducer and continue up the mast with Micro or Mid cable.

- Corrosion resistant Nickel plated Brass
- Weatherproof to IP67
- Reduces Mini Backbone to Micro/Mid Cable



### PRODUCTS

PART NUMBER	DESCRIPTION
NM-CF	Mini Male to Micro Female Reducer



## NM4P-01, NM4P-05 Specifications

### MECHANICAL

Molded Head Mat/Color	Thermoplastic PUR/Yellow
Outer Jacket Mat/Color	PVC/Yellow
Contact Carrier Mat/Color	Thermoplastic PUR/Yellow
Contact Mat/Plating	Brass/Gold
Coupling Nut Mat/Color	Brass/Nickel
Connector Insulation Mat	PVC

### ELECTRICAL

Conductors	4x16 (1.29mm) AWG
Rated Current	9.0 Amps
Rated Voltage	600 V

### ENVIRONMENTAL

Protection Class	IEC IP67, NEMA 1, 3, 4, 6P
Temperature Range	-40°C to 80°C -40°F to 176°F

## NF-NM4P-NF Specifications

### ELECTRICAL

Protection Circuit Slo-Blo Fuse	8 Amps, 250 V
Metric Fuse Block	5x20mm
Trip Time	4 sec Min to 100 sec max
Schottky Rectifier Type	MBR 3045 PT
Max: Reverse Voltage VRWM	= 45 V
Max: Average Fwd Cur IFRM	= 30 Amps
Peak Surge Cur t=8.3 sec., IFSM	= 200 Amps
Max Vf = 0.65 V @ 125°C and IF = 200 Amps	
Bus Line Minimum Conductor	16 AWG 8 Amps (Mini 5-Pin)
Supply Line Minimum Conductor	16 AWG 8 Amps (Mini 4-Pin)

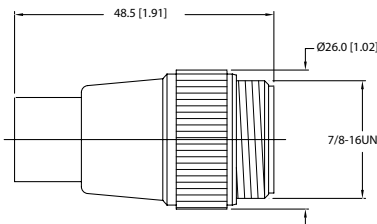
### ENVIRONMENTAL

Temperature Range	-40°C to 70°C (-40°F to 158°F)
Storage Temperature	-40°C to 85°C (-40°F to 185°F)

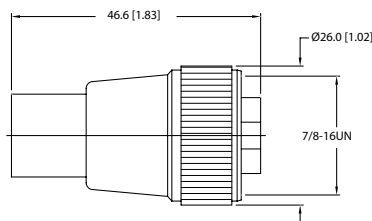
### APPROVALS

NMEA	NMEA 2000® Approved
IEC	IEC-61162-3

### MALE



### FEMALE



## Specifications

### MECHANICAL

Molded Head Mat/Color	Thermoplastic PUR/Blue-Gray TR-NM, TR-NF Thermoplastic PUR/Clear TRL-NM, TRL-NF
Contact Carrier Mat/Color	Thermoplastic PUR/Blue-Gray
Contact Mat/Plating	Brass/Gold
Coupling Nut Mat/Color	Brass/Nickel

### ELECTRICAL

Rated Voltage	300 V DC
Internal Resistor	120 Ohms (1/2 W)
Voltage Monitoring (Bus Power)	Green: Correct Polarity Red: Reversed Polarity – TRL-NM, TRL-NF

### ENVIRONMENTAL

Protection Class	IEC IP67, NEMA 1, 3, 4, 6P
Temperature Range	-40°C to 80°C -40°F to 176°F

### APPROVAL

NMEA	NMEA 2000® Approved
IEC	IEC 61162-3

## Specifications

### MECHANICAL

Contact Mat/Plating	Brass/Gold
Coupling Nut Mat/Color	Brass/Nickel

### ELECTRICAL

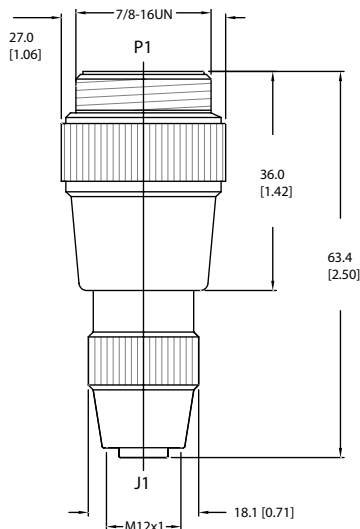
Rated Current	4.0 Amps
Rated Voltage	250 V

### ENVIRONMENTAL

Protection Class	IEC IP67, NEMA 1, 3, 4, 6P
Temperature Range	-40°C to 75°C -40°F to 167°F

### APPROVALS

NMEA	NMEA 2000® Approved
IEC	IEC-61162-3

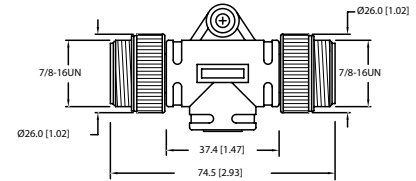




## Mini Gender Changers

Maretron cables have a male connector on one end and a female connector on the other end. Normally, the male connector points back towards the network power supply, but on some occasions, this gets reversed and a gender changer can be used to get back to the desired connector type.

- Waterproof seals for reliable connections
- Easily swap connector gender to get back to desired connector type



### PRODUCTS

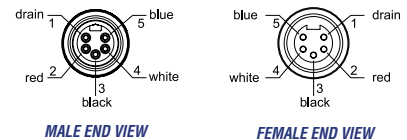
PART NUMBER	DESCRIPTION
NM-NM	Mini Gender Changer (Male/Male)
NF-NF	Mini Gender Changer (Female/Female)



## Mini Bulkhead Feed-Thru

The Bulkhead Feed-Thru allows ease of installation through panels or bulkheads and establishes future connection points in a network installation. The bulkhead feed-thru also maintains the integrity of watertight bulkheads by providing a waterproof seal and connection.

- Features rugged keyways for positive alignment of connections
- Waterproof rated to IP67



### PRODUCTS

PART NUMBER	DESCRIPTION
BHF-NM-NF	Mini Bulkhead Feed-Thru



## N2KMeter®

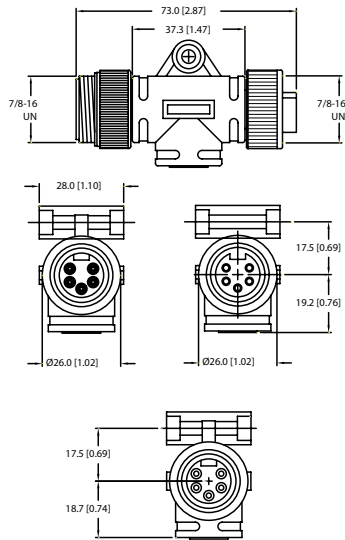
The N2KMeter® enables trained and untrained personnel to diagnose and trouble-shoot network installations quickly and easily. Completely passive on the network, the meter analyzes both data and power lines on the network. In seconds, both network-wide and device-specific traffic as well as power monitoring information is captured and displayed on a simple user interface.

- Diagnostic tool for NMEA 2000® networks
- Evaluates physical layer device functions on a network
- Data at boat can be locked in and then evaluated later on bench

### PRODUCTS

PART NUMBER	DESCRIPTION
N2KMeter-01	Diagnostic Meter w/1m Micro Cordset





## Specifications

### MECHANICAL

Molded Body Mat/Color	Thermoplastic PUR/Blue-Gray
Contact Carrier Mat/Color	Thermoplastic PUR/Blue-Gray
Contact Mat/Plating	Brass/Gold
Coupling Nut Mat/Color	Brass/Nickel

### ELECTRICAL

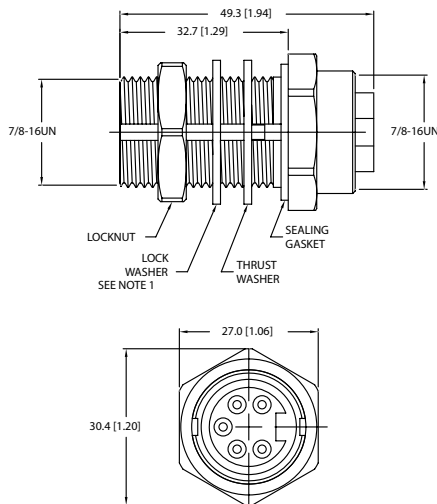
Rated Current	9.0 Amps
Rated Voltage	600 V

### ENVIRONMENTAL

Protection Class	IEC IP67, NEMA 1, 3, 4, 6P – NM-NM IEC IP67, NEMA 1, 3, 4, 13 – NF-NF
Temperature Range	-40°C to 70°C (-40°F to 158°F) -40°C to 55°C (-40°F to 131°F)

### APPROVAL

NMEA	NMEA 2000® Approved
IEC	IEC 61162-3



## Specifications

### MECHANICAL

Molded Head Mat/Color	Thermoplastic PUR/Blue-Gray
Housing Mat/Plating	Brass Nickel
Contact Mat/Plating	Brass/Gold
Gasket Material	Nitrile (Buna N)
Accommodates Wall (thick)	.040" (1.0mm) to .875" (22.2mm)

### ELECTRICAL

Voltage Rating	600 V DC
Max Amperage	9.0 Amps
Number of Conductors	5x22 (0.65mm) AWG

### ENVIRONMENTAL

Protection Class	IEC IP67
Temperature Range	-40°C to 105°C -40°F to 221°F

### APPROVAL

NMEA	NMEA 2000® Approved
IEC	IEC 61162-3

### Electrician Mode (Simple)

- Plug in and set N2KMeter® rotary switch to "autosearch"
- Identify network health
  - 😊 Happy face = healthy
  - 😐 Neutral face = nominal
  - 😞 Sad face = faulty
- Scroll through faults. Refer to user manual to link these faults to most likely network problems or freeze and **lock settings** for review back at the shop by an NMEA 2000® expert.

### Expert Mode (Advanced)

- Scroll through NMEA 2000® parameters for each active NMEA 2000® node (MAC ID)
  - Communication errors (rate, cumulative #)
  - Bandwidth (% of full usage)
  - Power supply and shield voltages
  - Data bit quality (dominant, recessive, +, -, differential voltage, CMV)
- Check values (both numeric and icons)
  - 😊 Happy face = within spec
  - 😐 Neutral face = very close to limit
  - 😞 Sad face = out of limit
- Refer to user manual to link these faults to most likely network problems

## Specifications

### MECHANICAL

Power Supply	Network 7 - 30 V DC <90 MA Batteries 2 x AA Alkaline Batteries 6 Hours of Operation Approx. 1 Year Data Retention
Connectors	Micro Connector
Band Rates	125k, 250k, and 500k (Auto-detect)
Analog Accuracy	Bus Power ± 100mv, Bus Signal ± 20mv
Analog Range	Bus Power 0 to 25 V with over/under Range Indication Bus Signal -5 to 10V with over/under range indication
Analog Sample Rate	Bus Power 1 Khz Bus Signal Ideal Sample Pt ± 250ns
Signal Error Threshold	NMEA 2000® Spec for Network Power
Bus Load Measurement	Detects Bus Idle in Real Time
Bus Message Rate Measurement	Detects 100% of Individual Error Frames in Real Time

### APPROVALS

NMEA	NMEA 2000® Approved
------	---------------------

# Maretron NMEA 2000® Network Installation Guide

## Installing an NMEA 2000® Network

Installing an NMEA 2000® network consists of interconnecting NMEA 2000® electronic devices using plug-and-play cables and connectors. The following pages provide a brief description of how to set up a NMEA 2000® network using five basic steps:

1. Cable and Connector Network Basics
2. Installing Terminators
3. Supplying Power
4. Grounding the Network
5. Checking the Network

Please note that this installation guide contains a brief description of the basic concepts of installing an NMEA 2000® network and Maretron suggests that you consult a trained professional for any installation. You can learn more about installing NMEA 2000® networks by contacting the National Marine Electronics Association (NMEA) at [www.nmea.org](http://www.nmea.org) and consulting the following documents:

- NMEA 2000® Standard for Serial-Data Networking of Marine Electronic Devices
- NMEA Installation Standards

## 1. CABLE AND CONNECTOR NETWORK BASICS

### 1.1 Network Topology

The NMEA 2000® cable system uses a trunk (sometimes referred to as the backbone) and drop line topology as shown in Figure 1.

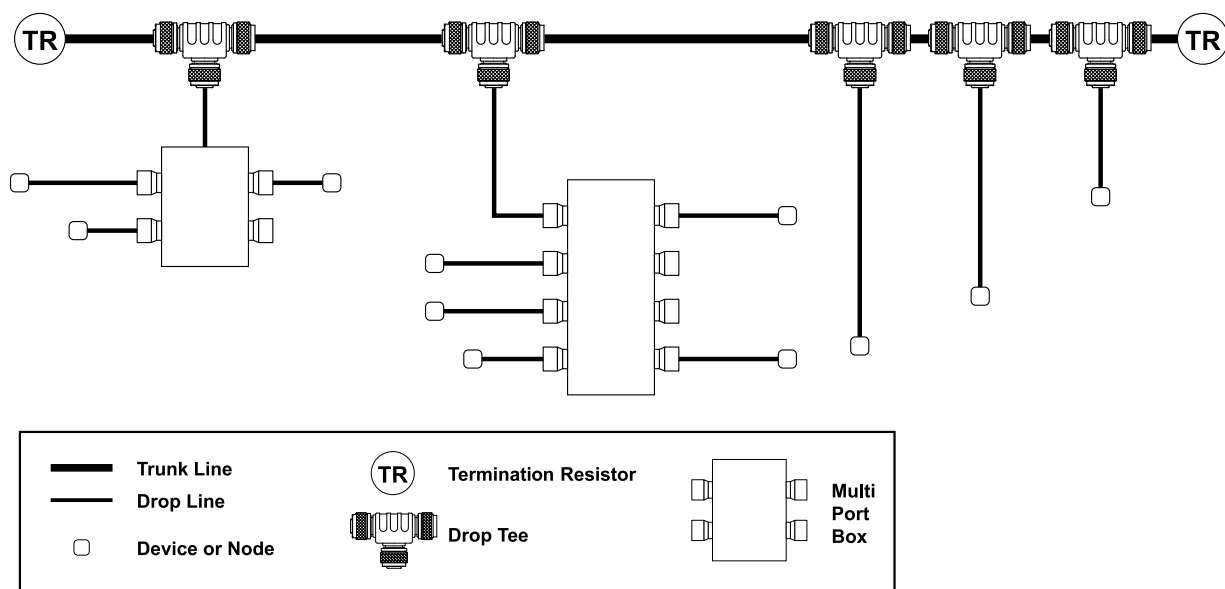
The NMEA 2000® cable system includes five wires within a single waterproof cable: two signal wires, power and ground wires, and a drain wire. The drain wire shields the signal, power, and ground wires from external Radio Frequency Interference (RFI) and helps reduce RFI emission from the cable.

You can connect devices using one of three cable options:

**Mini** - This is commonly used for the trunk line on the network because of its greater current carrying capacity (8 amps) as opposed to Micro cable (4 amps). Mini cable has an outside diameter in the range from 0.41 to 0.49 inches. Its maximum installed bend radius is 7x the cable diameter. You can also use this type of cable for drop lines.

**Mid** - This is commonly used for smaller networks as either the network trunk line or as drop lines. Mid cable and connectors are rated to 4 amps just like

FIGURE 1. NMEA 2000® Network Topology



the Micro cable, however the larger diameter power conductors within the Mid cable provides for less voltage drop over Micro cable, especially for long runs. The diameter of the Mid cable is 0.33 inches.

**Micro** - This cable type is typically used as the drop line connecting devices to the main trunk line with an outside diameter in the range from 0.24 to 0.28 inches. Micro cable has a smaller diameter and is more flexible than mini cable with an installation bend radius of 7x the cable diameter. Smaller networks use this type of cable for both the trunk and drop lines.

You construct the trunk line using double-ended cordsets connected between tees or taps. One end of the cordset has a male connector with male pins while the other end of the cordset has a female connector and female receptacles. The connectors are keyed so they can only connect to each other in one way. As an alternative to double-ended cordsets, you can make your own trunk line using bulk cable and field-attachable connectors. If you decide to add equipment later, you can simply disconnect a cordset from a tee, add another tee directly to the existing tee, re-connect the cordset and add the new component to the system using a drop cable. Alternatively, you could cut the trunk line, add two field-attachable connectors and insert a new tee. Trunk lines can also be run up to watertight bulkheads and connected to a waterproof bulkhead feed-thru connector to maintain the integrity of watertight compartments.

To drop off the trunk line, you connect a device using a tee connector. Daisy-chaining of devices is not allowed, as it is a requirement to be able to remove a component from the network without affecting any other device. This allows you to remove a device for servicing while the rest of the network remains operational. Multiport boxes are also available where instruments tend to be clustered, around the helm for example.

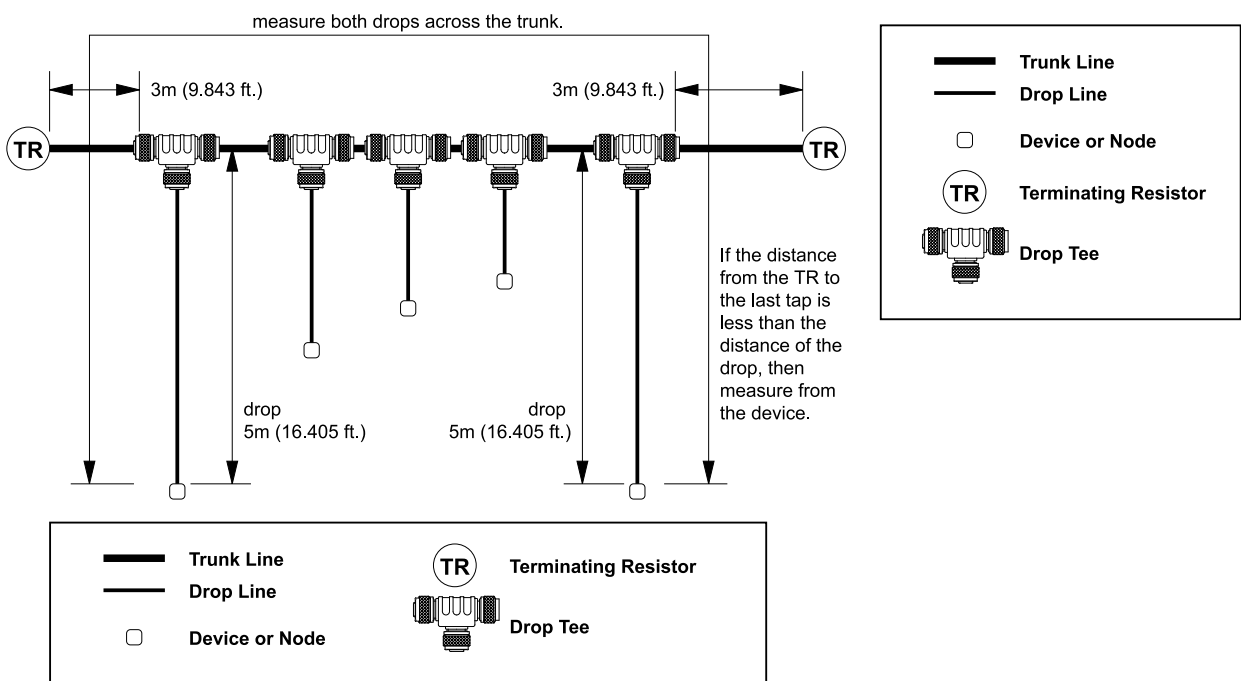
### 1.2 Maximum Cable Distance

The NMEA 2000® cable system uses a trunk (sometimes referred to as the backbone) and drop line topology as shown in Figure 1.

The cable distance between any two points (a point being an electronic product or terminator) must not exceed 250 meters (820 feet) for a system based on the Mini or Mid trunk cable or 100 meters (328 feet) for a system based on a Micro trunk cable.

For most cases, the maximum distance should be measured between termination resistors. However, if the distance from a trunk line tee to the farthest device connected to the trunk line is greater than the distance from the tee to the nearest terminating resistor (TR), then you MUST include the drop line length as part of the cable length in your maximum cable distance calculation. Figure 2 shows an example where both 5 meter drops must be included in the maximum cable distance since the drops are longer than the distance from the tee to termination resistor.

**FIGURE 2. Maximum Cable Length Determination**



### 1.3 Cumulative Drop Line Length

The cumulative drop line length refers to the sum of all drop lines, Mini, Mid or Micro cable in the cabling system. This sum cannot exceed 78 meters (256 feet). Figure 3 shows an example using four drop tees and two multiport drops to attach 11 devices to the trunk line. The cumulative drop line length is 37 meters (122 feet) and no single device is more than 6 meters (20 feet) from the trunk line.

### 1.4 Maximum Drop Line Length

The maximum cable distance from any device on a branching drop line to the trunk line is 6 meters (20 feet).

### 1.5 Maximum Number of Devices

A maximum of 50 physical devices can be connected to the network, and the disconnection of any device can not interrupt any other device on the network.

### 1.6 NMEA 2000® Connector

The Mini, Mid and Micro cables contain five wires: One twisted pair (red and black) for 12VDC power, one twisted pair (blue and white) for signal and a drain wire (bare).

The following table shows the color, name, and usage for each wire contained within the cable.

COLOR	NAME	USAGE
White	NET-H	Signal
Blue	NET-L	Signal
Bare	SHIELD	Drain
Black	NET-C	Ground
Red	NET-S	Power

### 1.7 NMEA 2000® Connectors

Connectors attach cables to devices or other components of the NMEA 2000® cable system. This allows the network to be completely “plug-and-play”. Connections can be made with pre-molded cordsets or with field-attachable connectors. The following diagram shows the pins found within Mini connector and the Micro and Mid connector and the corresponding wire colors for those pins.

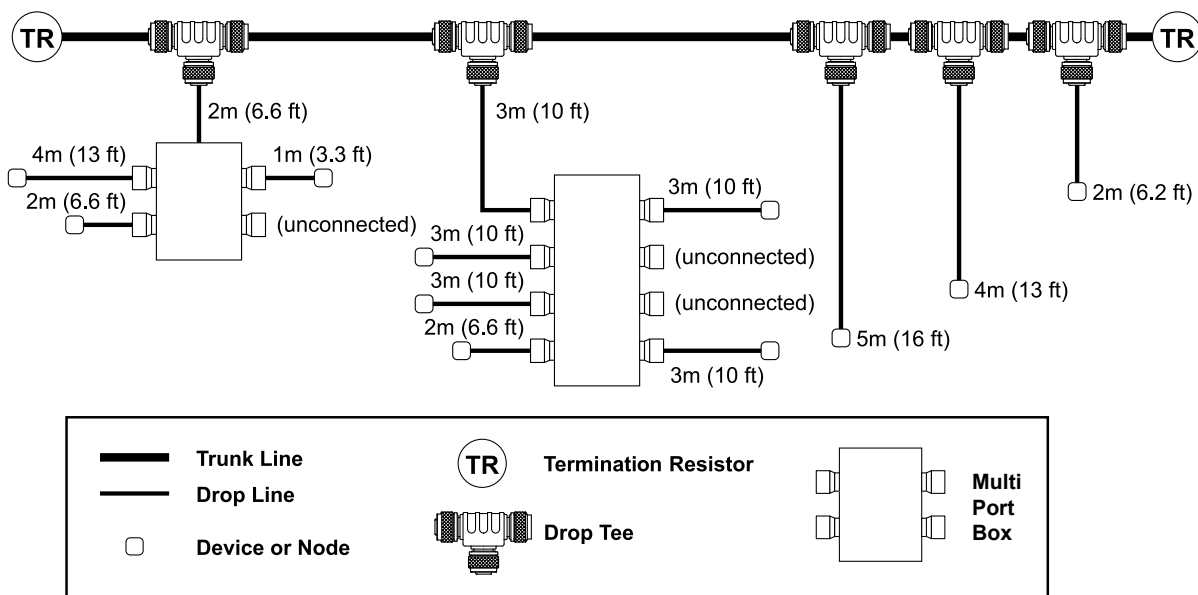
## 2. INSTALLING TERMINATORS

Termination resistors are attached to each end of the trunk cable to reduce reflections of the communication signals on the network. If you do not use termination resistors as described, the network will not operate properly. Termination resistors are typically connected directly to the last tee on the trunk line although they can be connected to a cordset extending from the last tee on a trunk line. Inline terminators are also available and they are used to terminate the network at the last product.

## 3. SUPPLY POWER

Termination resistors are attached to each end of the trunk cable to reduce reflections of the communication. NMEA 2000® networks can use a power supply originating from a single-point connection to the vessel's 12 volt battery or one or more isolated power supplies distributed along the network, but not a combination of battery and power supply connections. For the purpose of this installation guide, we will focus on the power source being a single-point connection to the vessel's battery. Over current protection should be provided and should be sized in accordance with ABYC E-11, AC and DC ELECTRICAL SYSTEMS ON BOATS, taking into consideration the

FIGURE 3. Maximum Cumulative Drop Line Length Determination





smallest gauge of cable being used for the backbone or drop cables. The NET-S wire is connected to the positive side of the battery while NET-C is connected to the negative side of the battery.

### 3.1 Mini Power Connection

Power is supplied to a Mini trunk line via a Powertap that is shown in Figure 4. Note that the Mini power cable does not have a shield wire as this connection is made to the screw terminal on the Powertap itself.

### 3.1 Mini Power Capability

Although Mini cable is rated to 8 amps, the cable system can support a total load of more than 8 amps. For example, 16 amps of power could be supplied to the middle of the trunk where 8 amps is supplied to both sides of the power tap. The Powertap can handle large loads as long as no more than 8 amps is drawn through any single segment of the trunk line. However, cable resistance may limit your application to less than 8 amps.

### 3.3 Micro/Mid Power Connection

Like the Mini power connection, power is supplied to a Micro/Mid trunk line via a Powertap, which is shown in Figure 5.

### 3.4 Micro/Mid Power Capability

Micro/Mid cable is rated to 4 amps but like Mini cable, strategic placement of the power source could support higher current. For example, 8 amps of power could be supplied to the middle of the trunk where 4 amps is supplied to both sides of the power tap. It can handle large loads as long as no more than 4 amps is drawn through any single segment of the trunk line. However, cable resistance may limit your application to less than 4 amps.

### 3.5 End-Powered Network

End-powered networks are typically seen on smaller vessels with only a few NMEA 2000® devices. Figure 6 shows an end-powered network.

### 3.6 Middle-Powered Network

A middle-powered network is typically found on larger vessels and is any network where the power is connected to the network at some location other than at the end. This network consists of two legs, one leg extending in each direction from the power insertion point. Figure 7 shows a middle-powered network.

### 3.7 Maximum Power Supply Voltage Drop

The NMEA 2000® network is designed to work properly as long as there is no more than a 1.5 volt difference in the power supply voltage between any two devices on the network. Therefore, you should perform an estimate of the voltage drop across a network using the following equation:

$$\text{Voltage Drop} = 0.1 \times \text{Network Loads} \times \text{Network Length} \times \text{Cable Resistance}/100$$

Where: Network Loads is sum of Load Equivalent Numbers (LEN) for all devices (see device nameplate)

Network Length is in meters

Cable resistance is in ohms/100 meters

Power supply voltage drop estimates resulting in less than 1.5 volts across the entire network require no further analysis. Likewise, estimates ranging between 1.5 and 3.0 volts require no further analysis as long as a mid-powered network is used. Occasionally, estimated power supply voltage drops will occur outside these limits and will require further consideration through detailed calculations by certified technicians.

FIGURE 4. Mini Powertap

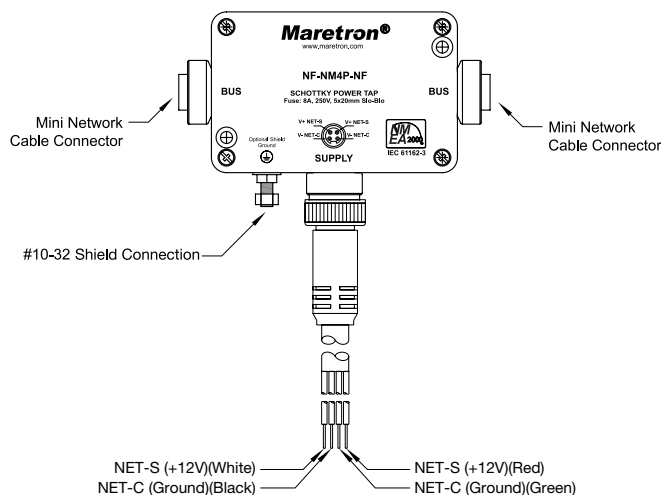
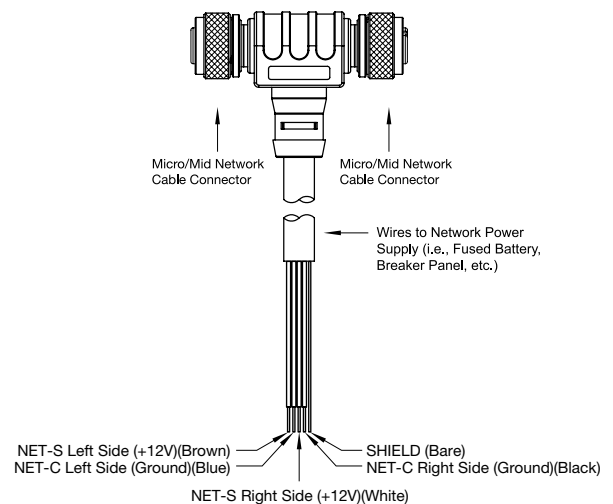


FIGURE 5. Micro/Mid Powertap



#### 4. GROUND THE NETWORK

The NMEA 2000® network should be grounded at ONE location. Grounding at more than one location may produce ground loops, which can cause problems with communications on the network. In addition to the ground wire, connect the drain or SHIELD wire at the supply ground location and NO other place.

#### 5. CHECKING YOUR NETWORK

Verify that the network has been correctly designed and installed by reviewing the following checklist:

- Number of devices does not exceed 50
- Maximum Mini cable distance between any two devices does not exceed 250 meters (820 feet)
- Maximum Micro/Mid cable distance between any two devices does not exceed 100 meters (328 feet)
- Maximum cumulative drop line length does not exceed 78 meters (256 feet)
- No drop should be greater than 6 meters (20 feet)
- Termination resistors are installed on both ends of the trunk
- The network is grounded at a single location
- The SHIELD wire is connected to a single point, the supply ground location

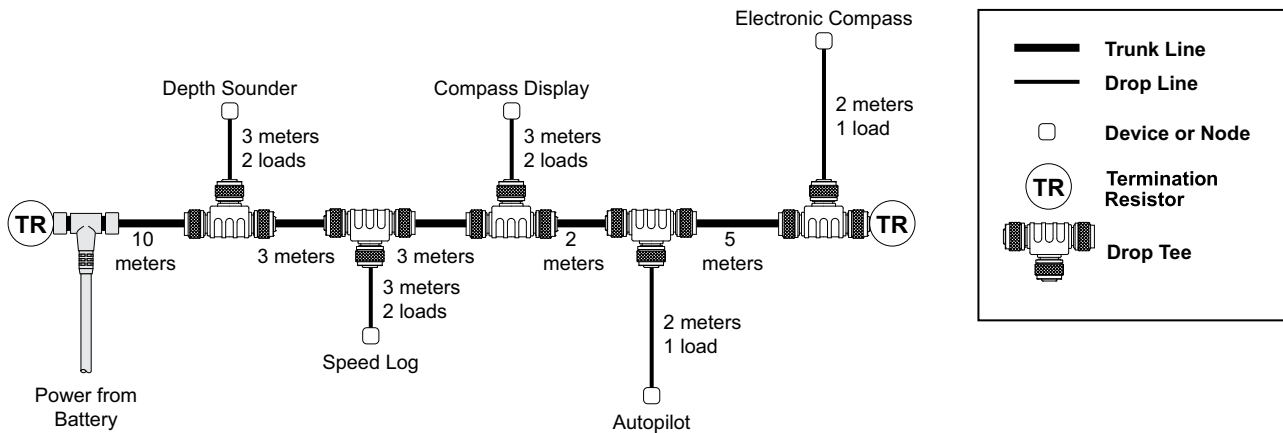
If you are having difficulties with the network make sure to check the following most common network problems:

- More or less than two terminating resistors
- Loose connections, make sure that all connectors are securely fastened
- Excessive trunk line length-especially with Micro cable
- Excessive drop line cable length
- Improper shield and ground connection at the power supply
- Shorts and opens in field-attachable connectors
- Failure to perform power distribution calculations for new installations and when adding new devices
- Using a typical device current rather than maximum current for power distribution calculations

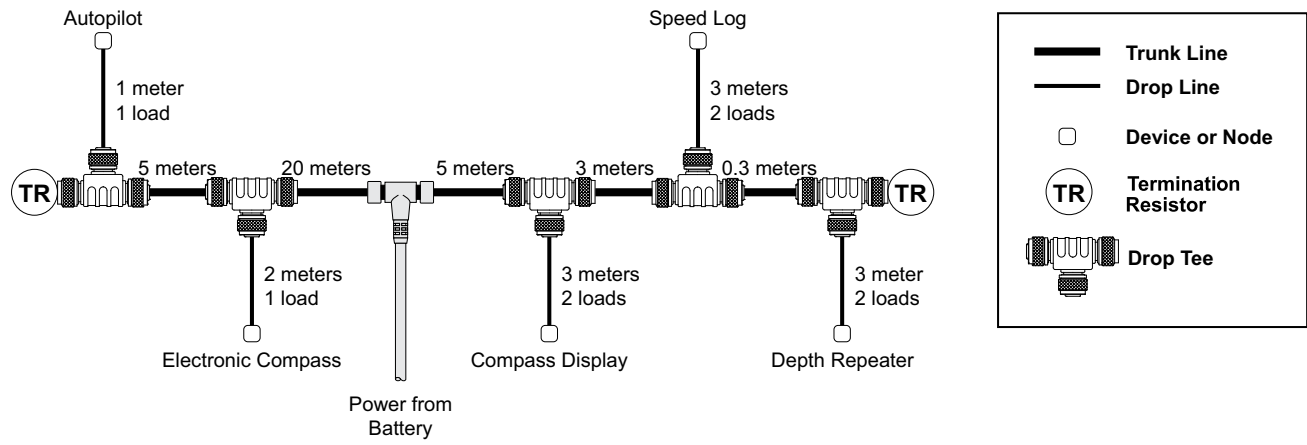
In order to insure the proper installation and configuration of an NMEA 2000® network, it is a good idea to have available at least one N2KMeter®. The N2KMeter® greatly simplifies network diagnostics and can detect many fault conditions including:

- Opens and shorts
- Incorrect topology
- Bad nodes
- Bad termination
- Improper shield connection
- Intermittent problems
- Excessive scan rate
- Common mode voltage

**FIGURE 6.** End-Powered Network

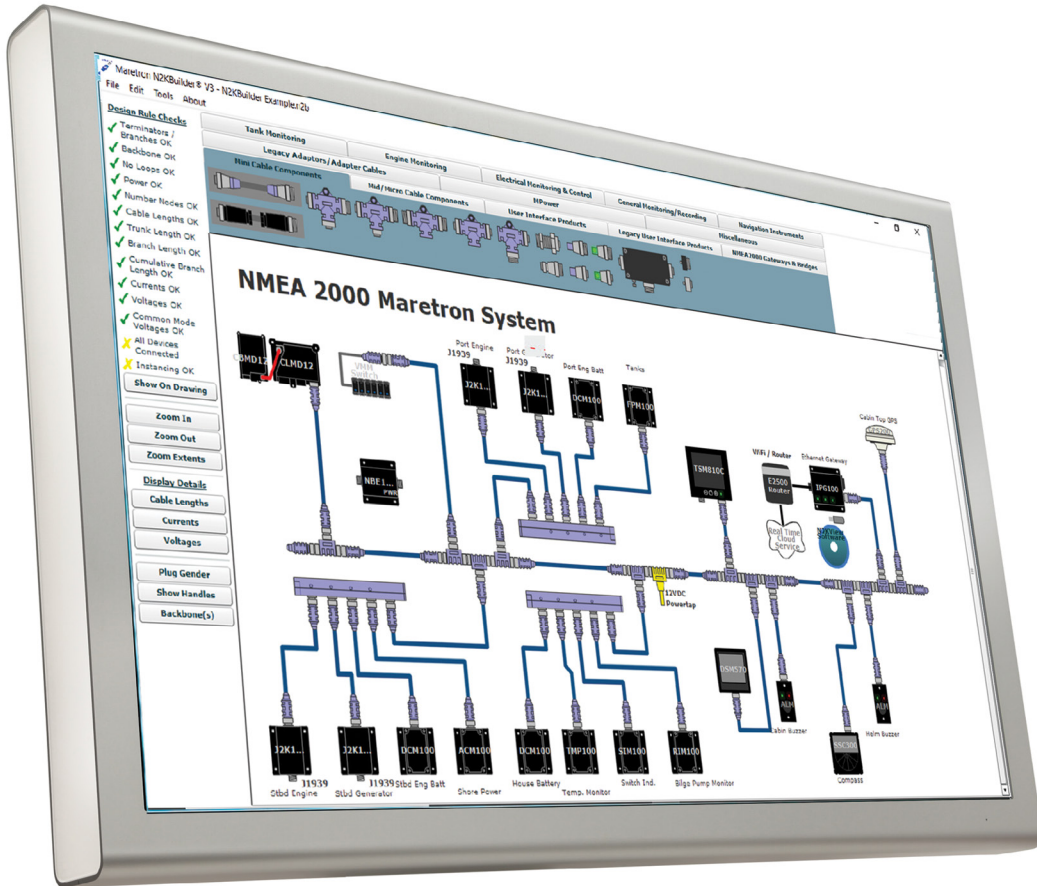


**FIGURE 7.** Middle-Powered Network



# N2KBuilder® V3

## NMEA 2000® Network Design Software



Map out your network design in N2KBuilder® V3, a powerful, free PC-based software used to plan, document, and validate the design of complex NMEA 2000 networks. In addition, N2KBuilder V3 will directly produce a Bill of Materials (BOM) for Maretron products, eliminating guesswork and transcription errors. Maretron recently added an MPower® Tab containing the builder information for the CLMD12, CLMD16, CBMD12, VMM6, and CKM12. With the latest version of N2KBuilder V3, configuration information created during the planning stage can be exported directly to N2KAnalyzer® V3.

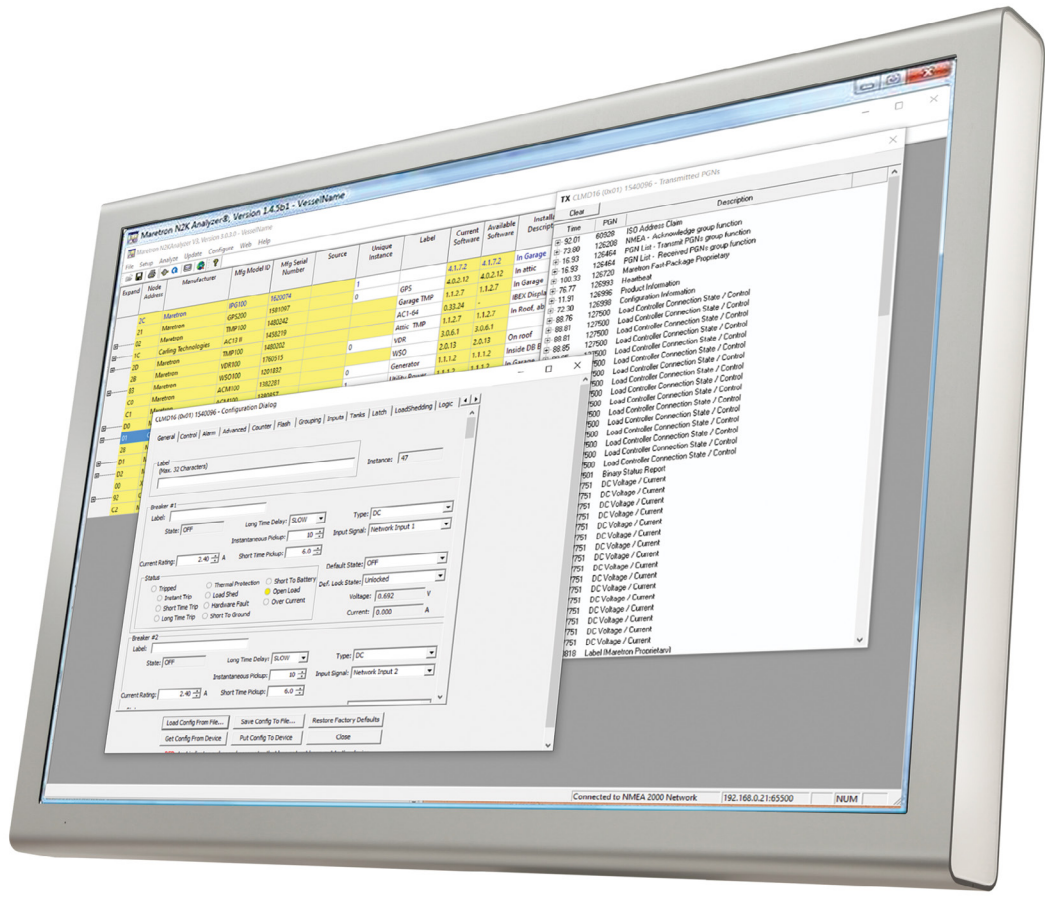
[www.maretron.com/products/N2KBuilder.php](http://www.maretron.com/products/N2KBuilder.php)





# N2KAnalyzer® V3

## NMEA 2000® Network Analysis Software



N2KAnalyzer® V3 is a Maretron software tool, currently offered free of charge with the purchase of a Maretron NMEA 2000/USB gateway (USB100) or Maretron NMEA 2000/Ethernet gateway (IPG100). N2KAnalyzer V3 provides you with a detailed view of all of the devices on an NMEA 2000 network and lets you perform a variety of configuration, updating, and troubleshooting tasks. Configure MPower® DC Load Controller Modules (CLMD12 and CLMD16) using N2KAnalyzer V3 and save your final configuration file using the N2KAnalyzer V3 'Save File' function.

[www.maretron.com/products/N2KAnalyzer.php](http://www.maretron.com/products/N2KAnalyzer.php)

# N2KExtractor®

NMEA 2000® Network Extractor



N2KExtractor® is a software tool, currently offered free of charge with the purchase of a Maretron Vessel Data Recorder (VDR100). N2KExtractor is used to extract information from the removable USB flash drive for analysis of any, or all, data recorded by the VDR100. Extracted data can be used for performance analysis, vessel tracking, preventative maintenance, warranty incident, and accident investigation, all in an effort to reduce operating cost and improve safety.

N2KExtractor is able to connect directly to the VDR100 through an Ethernet connection, and extract the data through the Ethernet connection, or can extract the data directly from the USB drive if the USB drive is plugged into the computer running N2KExtractor.

N2KExtractor is also able to connect to Maretron's Telemetric Cloud to download the data stored in the Cloud Server.

[www.maretron.com/products/N2KExtractor.php](http://www.maretron.com/products/N2KExtractor.php)







**Project Management**  
Hawley Communications, LLC

**Catalog Design**  
m.design

**Photographs**

Page 5: Miami city skyline; © f11photo, shutterstock.com

Page 8: © Maridav, shutterstock.com

Page 31: Adriatic Sea; Photograph © egon69, istockphoto.com

Page 41: Seattle, WA; Photograph © halbergman, istockphoto.com

Page 51: Port de Fontvielle in Monaco; Photograph © Artur Bogacki, istockphoto.com

Page 77: Miami Marina; Photograph © THE PALMER, istockphoto.com

Page 91: Hong Kong; Photograph © Lee Yiu Tung, shutterstock.com

**Maretron**<sup>®</sup>  
Vessel Monitoring & Control



***When Performance Matters,  
Count on **Maretron!*****

The World Class Standard in Vessel Monitoring & Control



**Littelfuse**<sup>®</sup>

**Maretron**<sup>®</sup>  
A Littelfuse<sup>®</sup> Brand

---

[littelfuse.com](http://littelfuse.com)

[maretron.com](http://maretron.com)